

ProVent®

Guide to Design and Usage

ProVent Single Stack System

Handling ■ Installation ■ Corrosion
Ease ■ Simplicity ■ Resistance

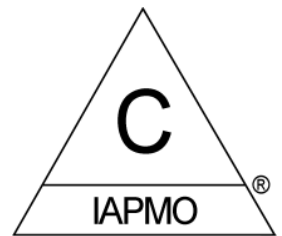

Copyright (c) 2006-2008, ProVent Systems Inc., All Rights Reserved

ProVent Systems Inc. ■ 1355 Capital Circle ■ Lawrenceville ■ Georgia ■ 30043-5866
770-339-1782 ■ 800-262-5355 ■ Fax: 770-339-1784

■ www.ProVentSystems.com ■

ProVent® System Components

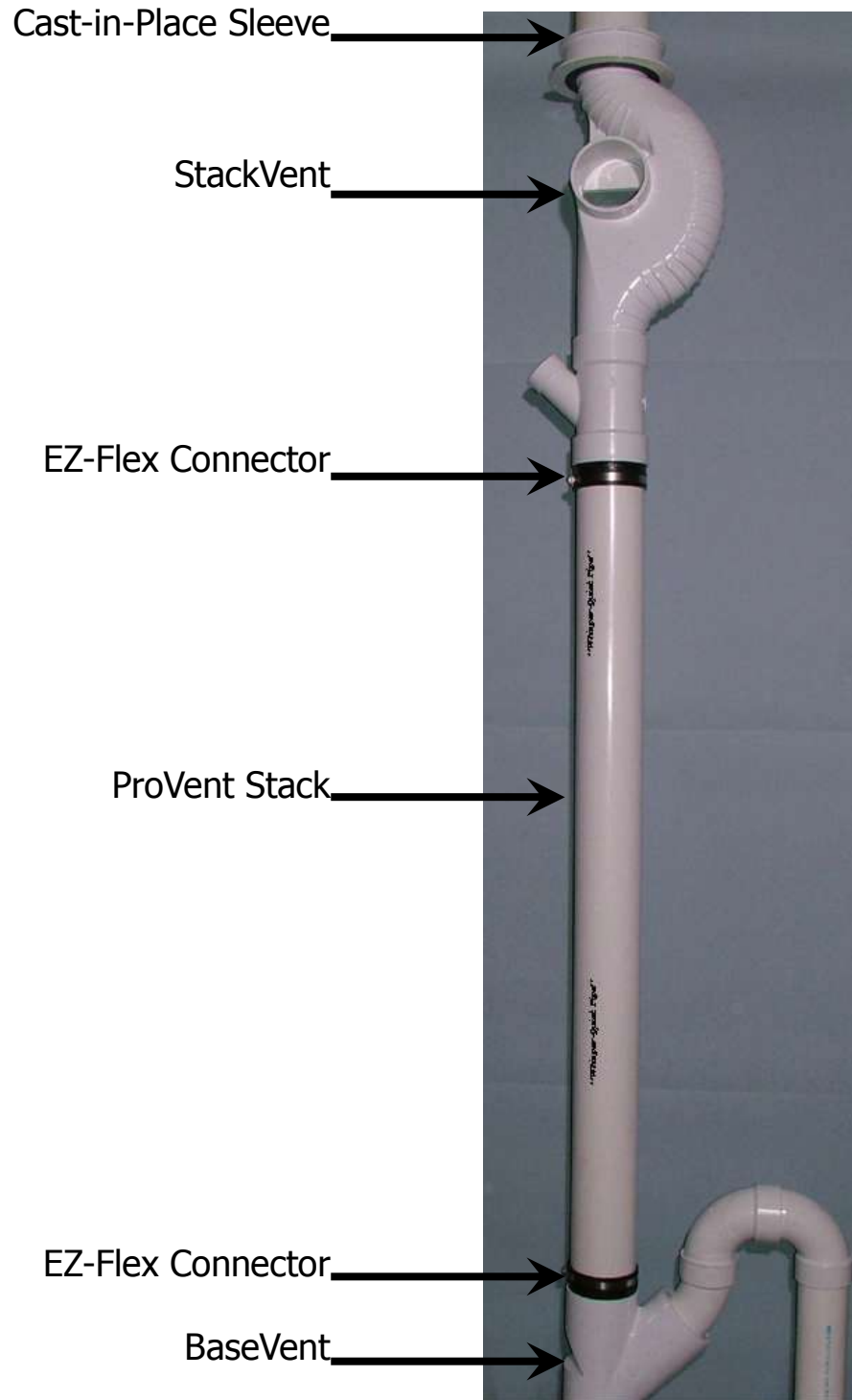



Table of Contents

Table of Contents	
Introduction to ProVent Systems	Page 4
Rules for ProVent Stacks and StackVent Fitting	Page 5
Rules for the ProVent BaseVent Fitting	Page 6
Rules for Branch Openings	Page 7
Chart 1: Fixture Unit Values by Type of Fixture	Page 8
Chart 2: Maximum Loading by Branch	Page 9
Chart 3: Maximum Loading by Stack	Page 9
Chart 4: Maximum Loading by Building Drain	Page 9
StackVent Dimensions	Page 10
BaseVent Dimensions	Page 11
Drawings to Illustrate Rules for Use of StackVent	Pages 12-17
Drawings to Illustrate Rules for Use of BaseVent	Pages 18-24
Drawings to Illustrate Rules for Branch Openings	Pages 25-30
Drawings 31a-f: Other Examples of ProVent Fixture Branches	Page 31
Drawing 32: Example of Side-by-Side Layouts	Page 32
Drawings 33 a-b: Example of Single Unit Layouts	Page 33
Drawings 34 a-c: Example of Back-to-Back Layouts	Pages 34-35





Introduction to ProVent™ Systems

A PVC Plastic Single Stack Waste and Vent System

The ProVent System™ is a plumbing engineered single stack system that finally offers the industry a PVC equivalent to the cast iron Sovent® system. Introducing the ProVent Stack Fitting™ and a ProVent Base Fitting™. This major change from cast iron fittings allows the installation of a complete PVC single stack drainage and vent system.

If you use PVC but you want the benefits of a Sovent®-style system, you can now use the ProVent System. Also, because the ProVent System is not subject to corrosion, you can safely use it in coastal regions.

The ProVent System™ is particularly effective in multi-story buildings such as hotels, condos and apartments where it creates considerable cost savings as well as enhanced performance and longevity. It increases the capacity of the plumbing stack, eliminates separate vent piping and minimizes pipe penetrations.

The ProVent Stack and the ProVent Base Fittings reduce the maximum flow velocity, increase the stack waste water capacity and control the interior air pressures that can cause siphonage and blowouts of fixture traps.

ProVent Systems™ Fittings were designed to further enhance acoustic performance by increasing wall thicknesses and providing sound absorbing ribs that greatly reduces the water noise associated with plastic piping. This new system creates a sound-tested "Whisper-Quiet PVC Plumbing System".

This type of single stack system has been used for over forty years, with proven performance throughout the world. In addition to these proven benefits, the ProVent System provides the following:
Flexible couplings that connect the piping from the Base to the Stack Fitting provide for a pipe expansion and contraction system that works.

A StackVent system that fits plumbing walls and will fit drop ceilings without requiring special recess boxes. Easier installation due to its light weight (7.5 pounds) and elimination of the need for hangers (when used with ProSet Systems fire-rated penetrations) .

The plumbing approvals for using this new system are granted under the Alternate Materials & Methods or the Alternate Professional Engineers Design criteria in the Plumbing Codes based on ASSE 1043, ASTM D-2665 & NSF 14 Test & Design Standards.



1. Rules for the ProVent™ Stack and StackVent Fitting

Note: The Charts referred to below are contained on pages 6 and 7.

1.1 The ProVent stack must be sized by the total number of fixture units (D.F.U.) discharging into it. Chart 1 provides the number of fixture units by individual fixture. The sum of the fixture units for all fixtures discharging into the stack equals the total fixture units. Chart 3 provides the required stack size by total fixture units. The stack size shall continue full size through the roof.

1.2 A ProVent Stack Fitting is required to be used at each floor level when the horizontal soil or waste branch collected is either the same size or one pipe size smaller than the vertical ProVent Stack Fitting.

1.3 Waste branches that are two (2) pipe sizes smaller than the stack can be connected with a sanitary tee or wye directly into the ProVent stack (between ProVent Stack Fittings).

1.4 If there are no branch connections at a floor level, there is no need to use the ProVent Stack Fitting. Instead, a double in-line offset must be used in its place. The vertical interval between the Stack Fitting and the in-line offset shall not exceed 20 feet and no more than two (2) consecutive double in-line offsets can be used.

1.5 Offsets in the stack of more than 60 degrees require a ProVent Base Fitting with a pressure relief vent line tied in to the top vertical portion of the stack. Branch piping can be connected to the offset soil piping. A 45 degree stack offset is not considered an offset. Waste branches (1) one pipe size smaller can be connected to the pressure relief vent line with the exception of washing machine wastes. It is recommended that Washing machine wastes should be isolated from other fixtures. If they must be combined, call for technical support.

1.6 The building drain size is determined by the total fixture unit load (Chart 4) from the combination of stacks and other soil or waste branches that discharge into it (Charts 1, 2 and 3).

1.7 Stacks may offset above the highest fixture served. When the horizontal offset exceeds twenty (20) feet, the diameter of the horizontal offset and the vent through the roof must be increased one pipe size

1.8 Combinations of vent stacks may be tied together above the highest fixture served before going through the roof. The combined vertical stack must be increased (1) one pipe size larger than the combined stacks. If the distance between the two (2) stacks that connect is greater than twenty (20) feet, the horizontal branch must be one (1) pipe size larger than the downstream stack.

Note: The corresponding drawings are shown as examples of the rules. However, there may be other options not shown in the drawings.



2. Rules for the ProVent™ BaseVent Fitting

Note: The Charts referred to below are contained on pages 6 and 7.

2.1 A ProVent Base Fitting must be installed at the base of each vertical stack before it enters the horizontal building drain. If the vertical distance to the closest ProVent Stack Fitting exceeds twenty feet (20'-0") an inline offset must be installed within five feet (5'-0") above the ProVent Base Fitting. The building drain size is calculated by using Chart 4 in accordance with the fixture unit values (D.F.U.) for all fixtures discharging into it as shown in Chart 1.

2.2 The ProVent Base Fitting has a pressure relief vent opening that extends up then makes a 180 degree turn downward using pipe and fittings that connect to the horizontal building drain at a point no less than 10 pipe diameters downstream from the center line of the vertical stack to the centerline of the branch wye. The pressure relief vent line may run parallel to the horizontal drain and must connect above the centerline of the drain. Branch soil or wastes are allowed when they are connected above the horizontal drain line.

2.3 A ProVent Base Fitting must be used on any stack offsets of more than 60 degrees with the pressure relief vent connection running from the base fitting back into the top vertical portion of the stack drop.

2.4 Soil and waste branches can be connected into the building drain between the stack and the relief vent when the connections are made above the center line of the building drain. The branch fixture unit loading should be in accordance with the pitch of the pipe as shown in Chart 3.

2.5 Waste branches at least (1) one pipe size smaller can be connected to the pressure relief horizontal vent line. Washing machine drains should not connect to the pressure relief vent line.

2.6 Soil or waste branches may connect directly into the vertical stack directly below the ProVent Base Fitting only when the connections are made using fittings such as a combination wye and 1/8 bend.

2.7 Conventional waste & vent plumbing systems can connect downstream from the pressure relief vent to pick up remote fixtures. Conventional revents can tie back into the ProVent vertical stack with vent sizing based on the additional fixture units vented or can be separately vented through the roof in accordance with locally accepted plumbing code vent sizing.

Note: The corresponding drawings are shown as examples of the rules. However, there may be other options not shown in the drawings.



3. Rules for **Branch Openings**

Note: The Charts referred to below are contained on pages 6 and 7.

3.1 All branch piping sizes and loads should be in accordance with Chart 3. Branch piping should have a minimum of 1/8" per foot pitch.

3.2 Branches that change directions three (3) times by 90 degrees should increase one pipe size at the offset nearest the stack. This increase does not apply if one (1) of the changes can be made with two (2) forty five degree fittings or a short sweep 90 degree fitting.

3.3 If two (2) 3.5 gpf public water closets are connected to the same branch, the first connection can be 3" then increased to 4" at the second connection. This increase is not required for the 1.6 gpf flush water closets. Check manufacturers installation instructions for pressure assisted type water closets that may require special fittings for back to back installations.

3.4 4" Size branches shall not exceed a developed length of 27 feet. 3" Size branches shall not exceed a developed length of 15 feet. 2" Size branches shall not exceed a developed length of 15 feet. 2" branches for washing machines should not exceed 5 feet. These lengths include any horizontal pipe offsets but the length of the vertical drop arms is not included. Horizontal to horizontal branch connections should be made with wye combinations or heel outlet fittings.

3.5 Vertical branches should not exceed 40". A 45 degree offset can extend the drop pipe to 40" from the top 45 degree fitting to the fixture outlet. When a vertical drop into a horizontal waste exceeds 10 feet both must increase one (1) pipe size.

3.6 1-1/4" size fixture traps can be connected back to back into one 2" vertical drop. 1-1/2" size fixture traps require separate 2" drops. 1-1/2" and larger traps can use a single vertical drop by increasing the drop one (1) pipe size. Note: Horizontal waste branches without vertical drops are sized per chart 2.

3.7 An alternate to increase developed lengths can be done by using a revent line or by telescoping smaller to larger pipe sizes or by using an Air Admittance Valve where applicable and permitted. The revent line shall be routed vertically and horizontally and tie in above the flood rim level using a wye branch looking up.

Note: The corresponding drawings are shown as examples of the rules. However, there may be other options not shown in the drawings.



Chart 1: Fixture Unit Values by Type of Fixture

Fixture	Fixture Units
Bathrooms	
Water Closet: Flush Valve	6
Water Closet: Tank Operated	4
Urinal: Pedestal	6
Urinal: Non-Pedestal	2
Bidet	2
Bathtub (with or w/o shower)	2
Shower (per showerhead)	2
Lavatory	1
Bathroom Group 1: Lavatory, Bathtub (with or w/o shower), Flush Valve Water Closet	8
Bathroom Group 2: Lavatory, Bathtub (with or w/o shower), Tank Operated Water Closet	5
Kitchens	
Sink (with or w/o waste disposal)	2
Sink (scullery)	2
Dishwasher	2
Laundry Room	
Washing Machine	3
Laundry Tray (One or Two Compartments)	2
Specialty Fixtures	
Sink: Flushing Rim with Valves	6
Sink: Service (P-Trap)	2
Sink: Service (Standard Trap)	3
Lavatory: Surgeon	2
Lavatory: Hairdresser, Beauty Parlor	2
Miscellaneous	
Floor Drain: 2"	2
Drinking Fountain	1



Maximum Loading by Branch, Stack and Building in Fixture Units

Chart 2: Maximum Loading by Branch

	<i>Slope 2% (1/4" per foot)</i>	<i>Slope 1% (1/8" per foot)</i>
<i>Drain Size</i>	<i>Fixture Units</i>	<i>Fixture Units</i>
2"	6	5
3"	16	13
4"	90	72

Chart 3: Maximum Loading by Stack

<i>Stack Size</i>	<i>Fixture Units</i>
3"	64
3" (over 7 stories)	102
4"	504
5"	1,010
6"	2,200
8"	3,900

Chart 4: Maximum Loading by Building Drain

	<i>Slope 2% (1/4" per foot)</i>	<i>Slope 1% (1/8" per foot)</i>
<i>Drain Size</i>	<i>Fixture Units</i>	<i>Fixture Units</i>
3"	42	36
4"	216	180
5"	350	280
6"	850	680
8"	2,700	2,160
10"	3,900	3,120
12"	5,800	4,640



StackVent Dimensions

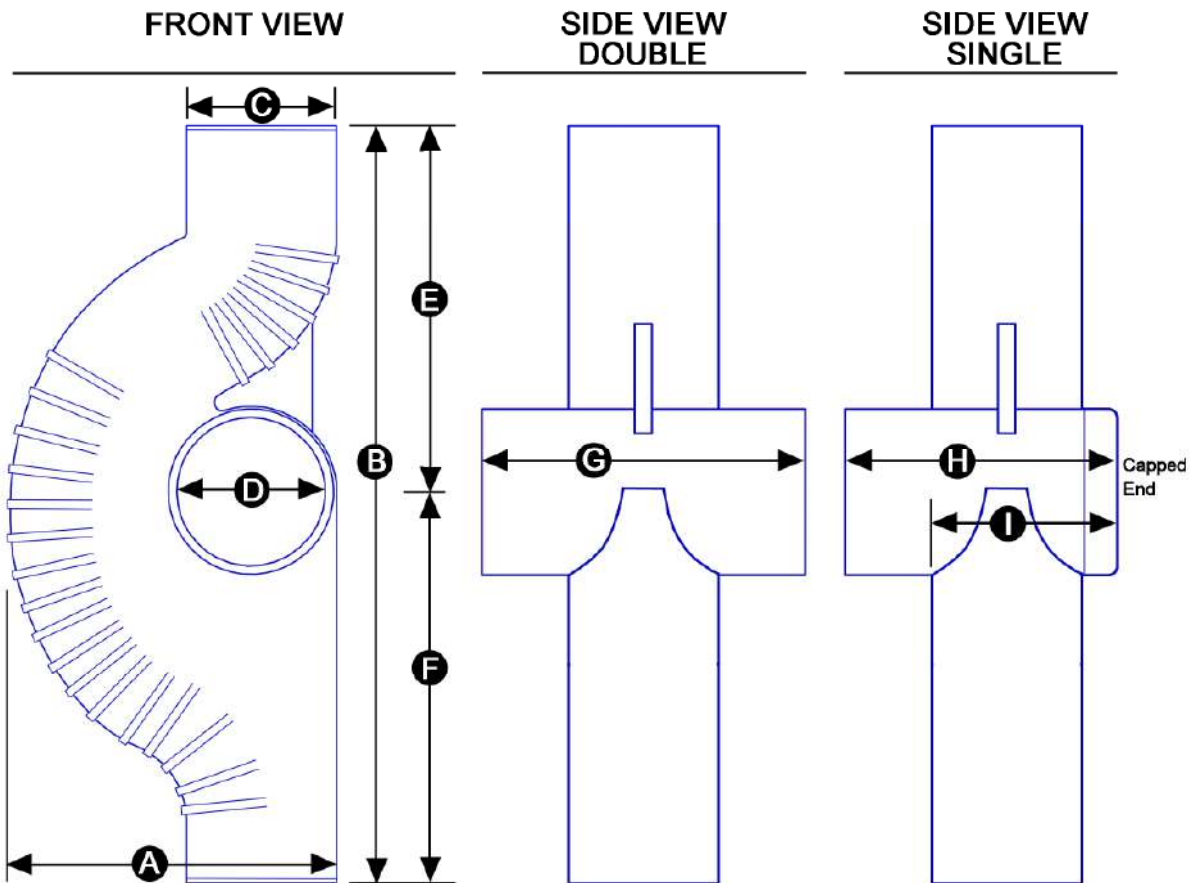

	A	B*	C	D	E*	F	G	H	I
3"	7-3/4"	18"	3-1/2"	3-1/2"	9"	9"	6-1/2"	5-3/4"	4-1/4"
4"	9-3/4"	22-1/2"	4-1/2"	4-1/2"	10-1/2"	12"	8"	7"	5-1/4"

* For effective height after installation, subtract 3" from this measurement since the top spigot end inserts 3" up into the ProSet Sleeve

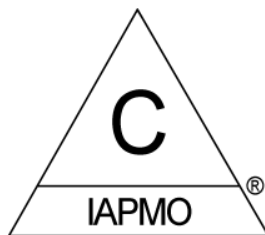

BaseVent Dimensions

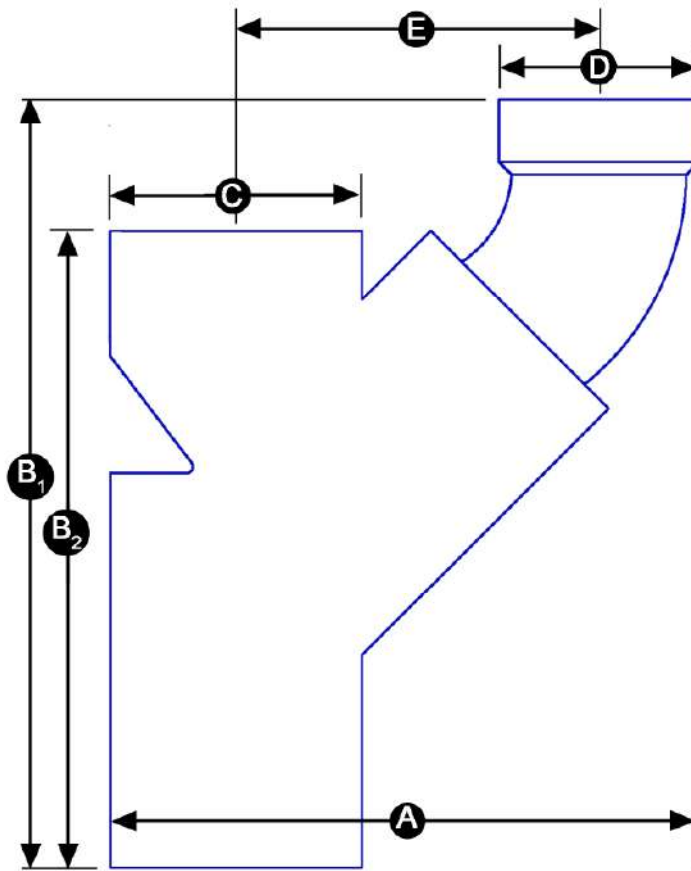

	A	B₁	B₂	C	D	E
3" x 2"	9-1/2"	11"	9-1/4"	4"	2-3/4"	6"
4" x 3"	11-1/2"	13-1/2"	11"	5"	4"	7"

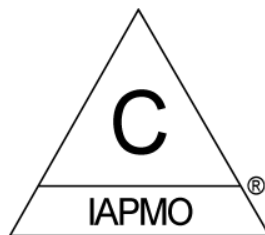

Stack and StackVent Fitting Rule 1.2

A ProVent Stack Fitting is required to be used at each floor level when the horizontal soil or waste branch collected is either the same size or one pipe size smaller than the vertical ProVent Stack Fitting.

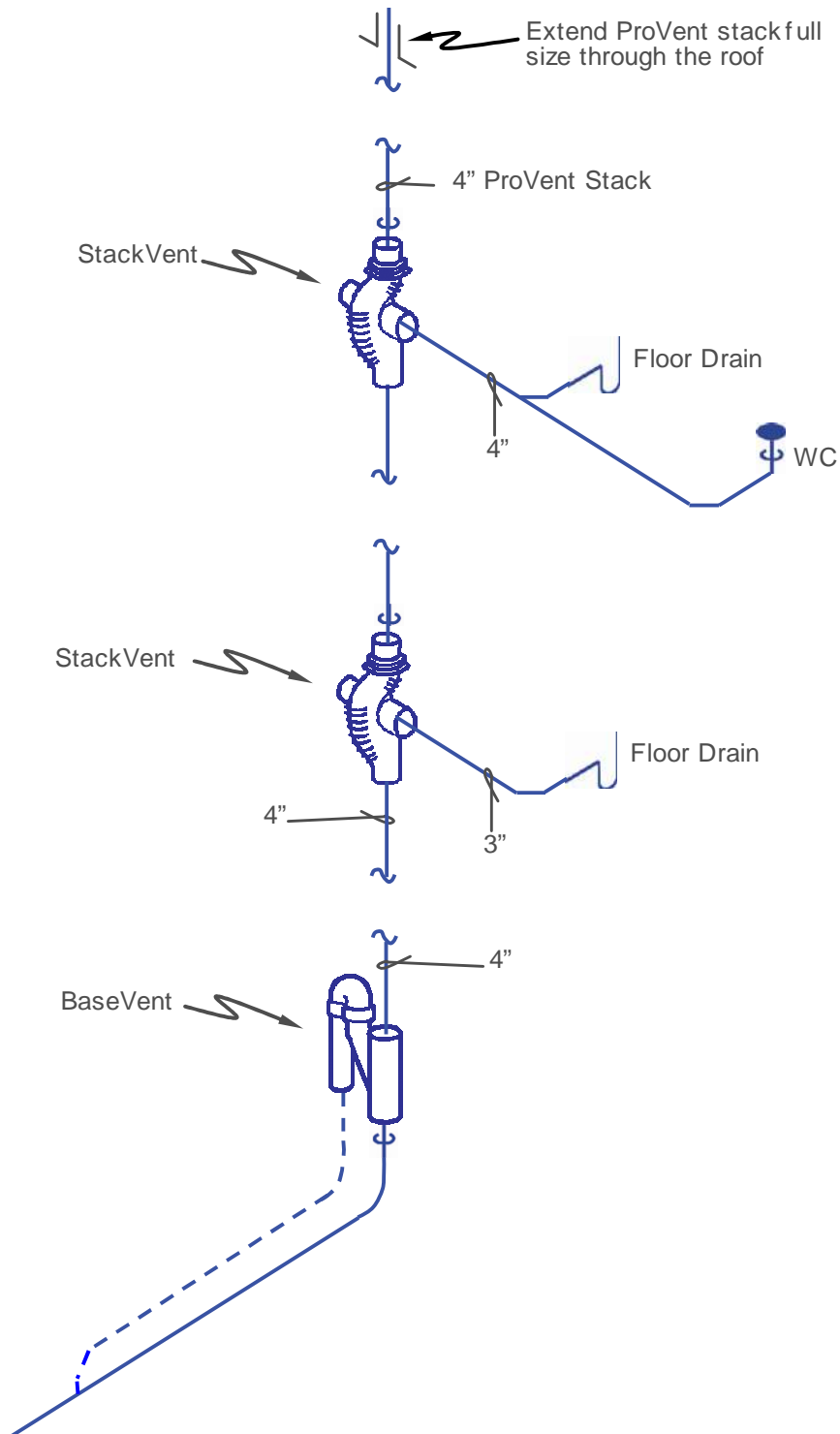

Drawing 1.2



Stack and StackVent Fitting Rule 1.3

Waste branches that are two (2) pipe sizes smaller than the stack can be connected with a sanitary tee or wye directly into the ProVent stack (between ProVent Stack Fittings).

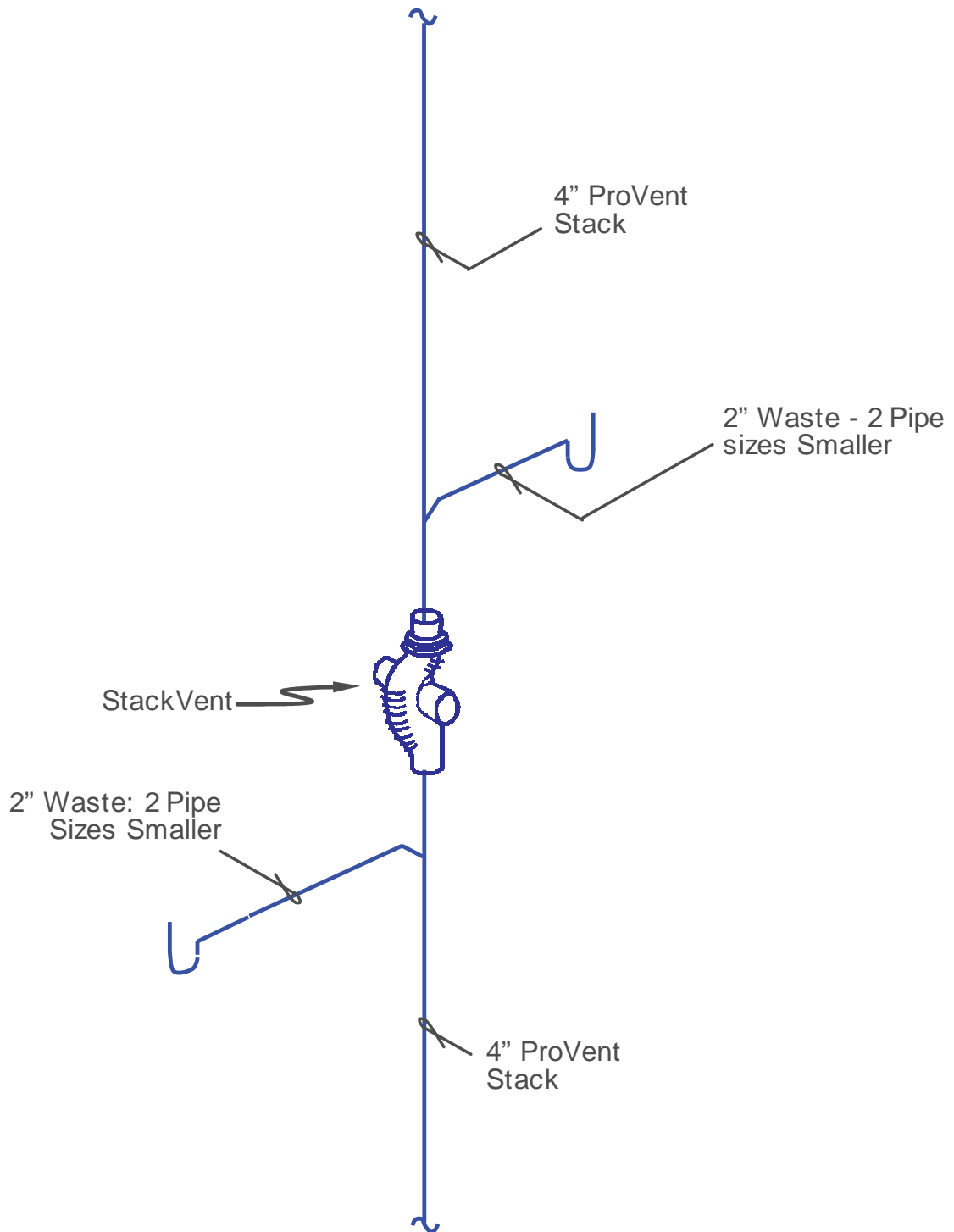

Drawing 1.3



Stack and StackVent Fitting Rule 1.4

If there are no branch connections at a floor level, there is no need to use the ProVent Stack Fitting. Instead, a double in-line offset must be used in its place. The vertical interval between the Stack Fitting and the in-line offset shall not exceed 20 feet and no more than two (2) consecutive double in-line offsets can be used.

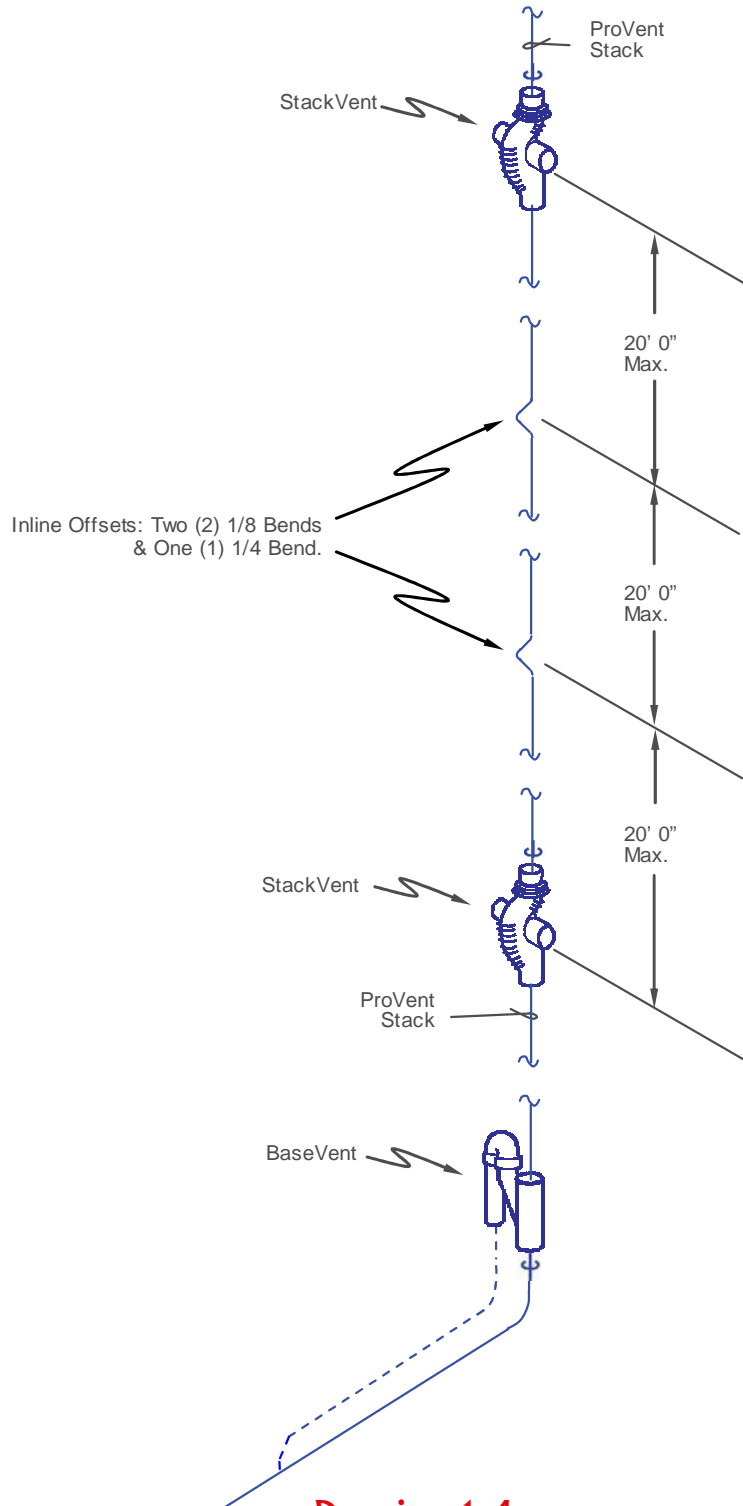

Drawing 1.4



Stack and StackVent Fitting Rule 1.5

Offsets in the stack of more than 60 degrees require a ProVent Base Fitting with a pressure relief vent line tied in to the top vertical portion of the stack. Branch piping can be connected to the offset soil piping. A 45 degree stack offset is not considered an offset. Waste branches (1) one pipe size smaller can be connected to the pressure relief vent line with the exception of washing machine wastes. It is recommended that Washing machine wastes should be isolated from other fixtures. If they must be combined, call for technical support.

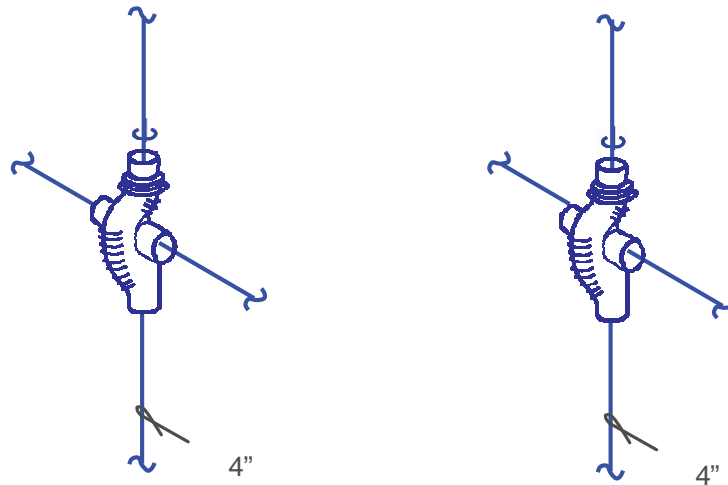
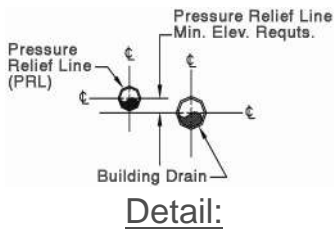
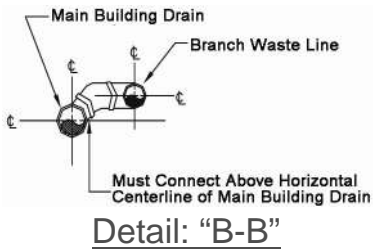
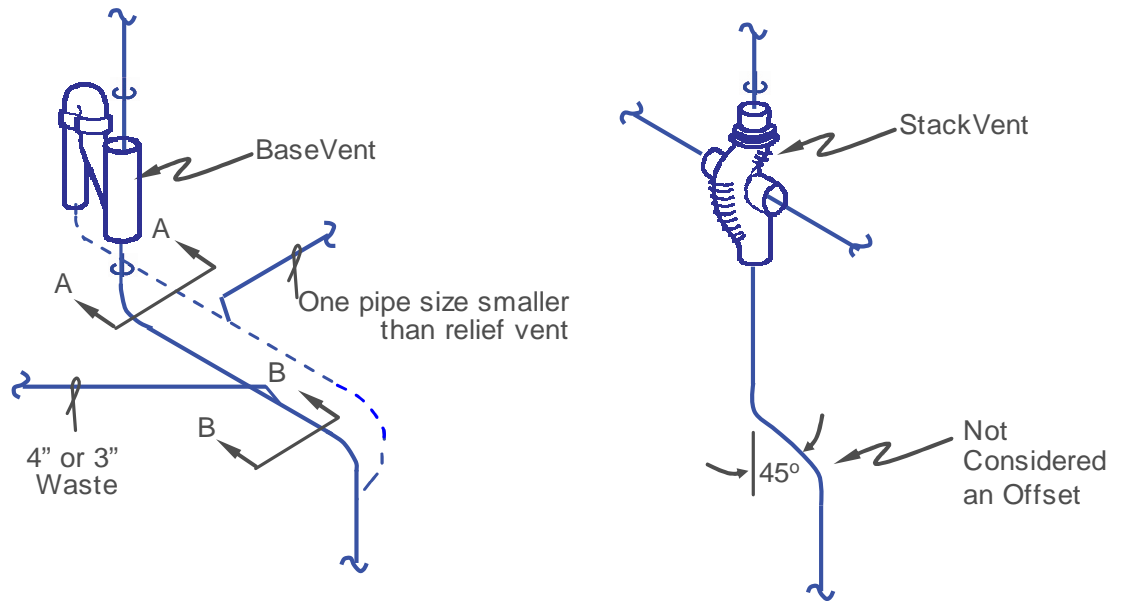

Drawing 1.5



Stack and StackVent Fitting Rule 1.7

Combinations of vent stacks may be tied together above the highest fixture served before going through the roof. The combined vertical stack must be increased (1) one pipe size larger than the combined stacks. If the distance between the two (2) stacks that connect is greater than twenty (20) feet, the horizontal branch must be one (1) pipe size larger than the downstream stack.

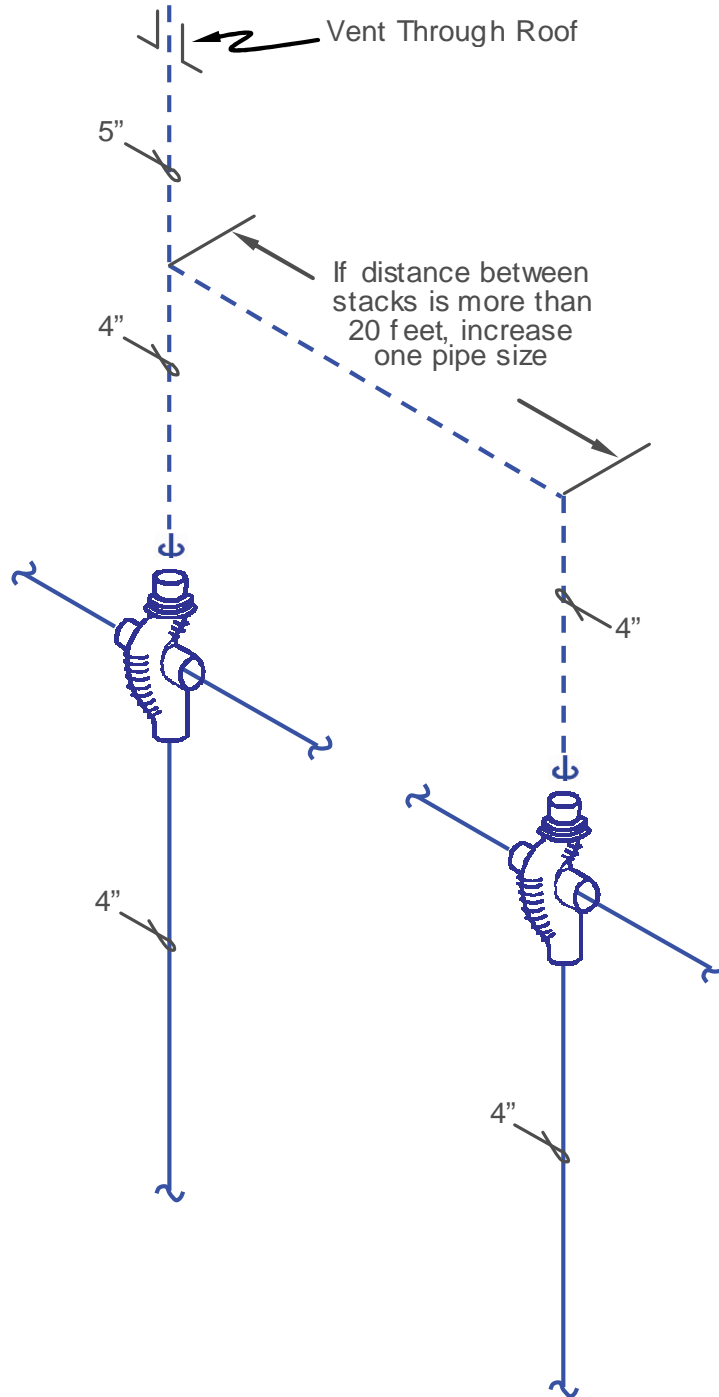

Drawing 1.7



Stack and StackVent Fitting Rule 1.8

Stacks may offset above the highest fixture served. When the horizontal offset exceeds twenty (20) feet, the diameter of the horizontal offset and the vent through the roof must be increased one pipe size

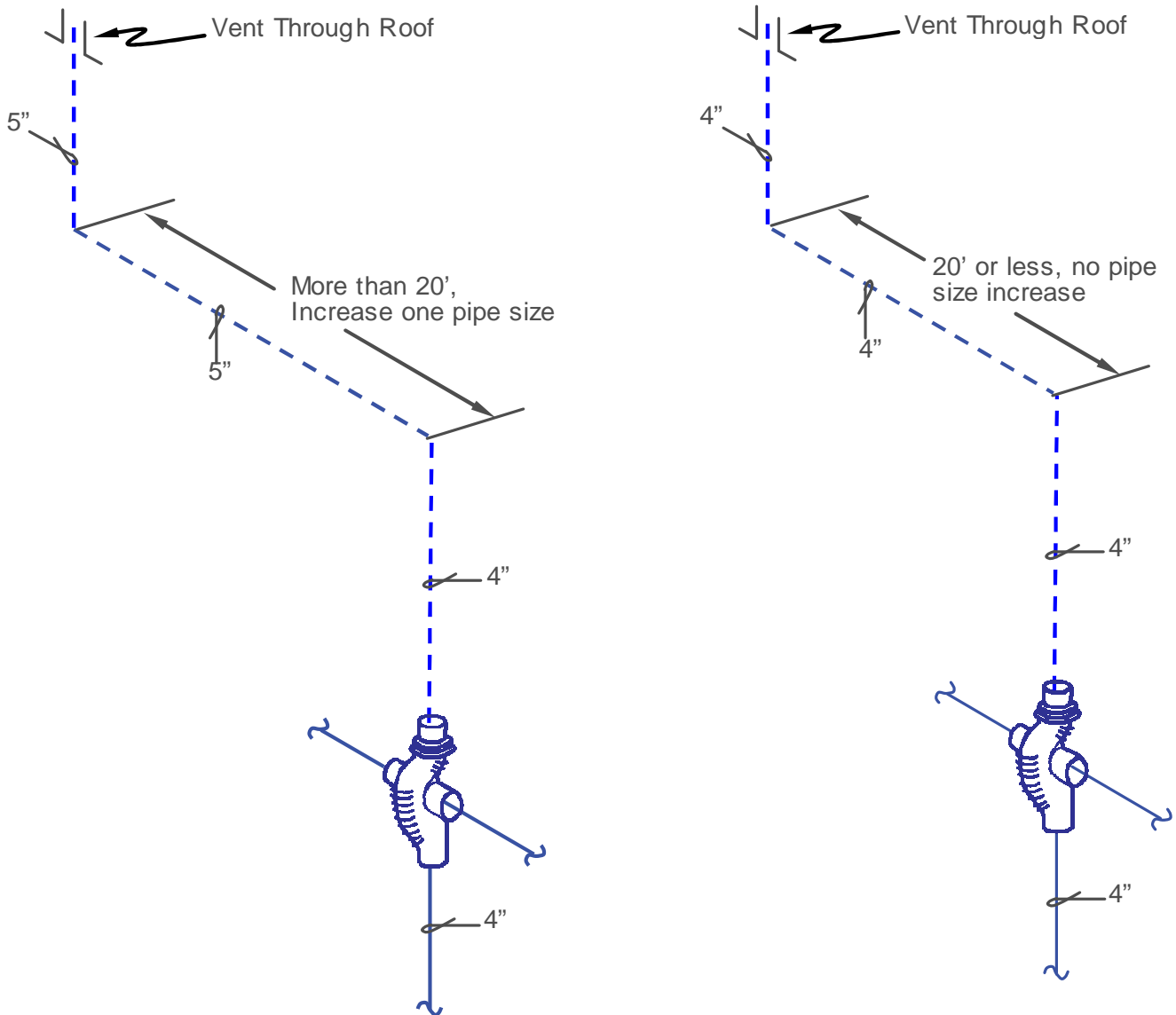

Drawing 1.8



BaseVent Fitting Rule 2.1

A ProVent Base Fitting must be installed at the base of each vertical stack before it enters the horizontal building drain. If the vertical distance to the closest ProVent Stack Fitting exceeds twenty feet (20'-0") an inline offset must be installed within five feet (5'-0") above the ProVent Base Fitting. The building drain size is calculated by using Chart 4 in accordance with the fixture unit values (D.F.U.) for all fixtures discharging into it as shown in Chart 1.

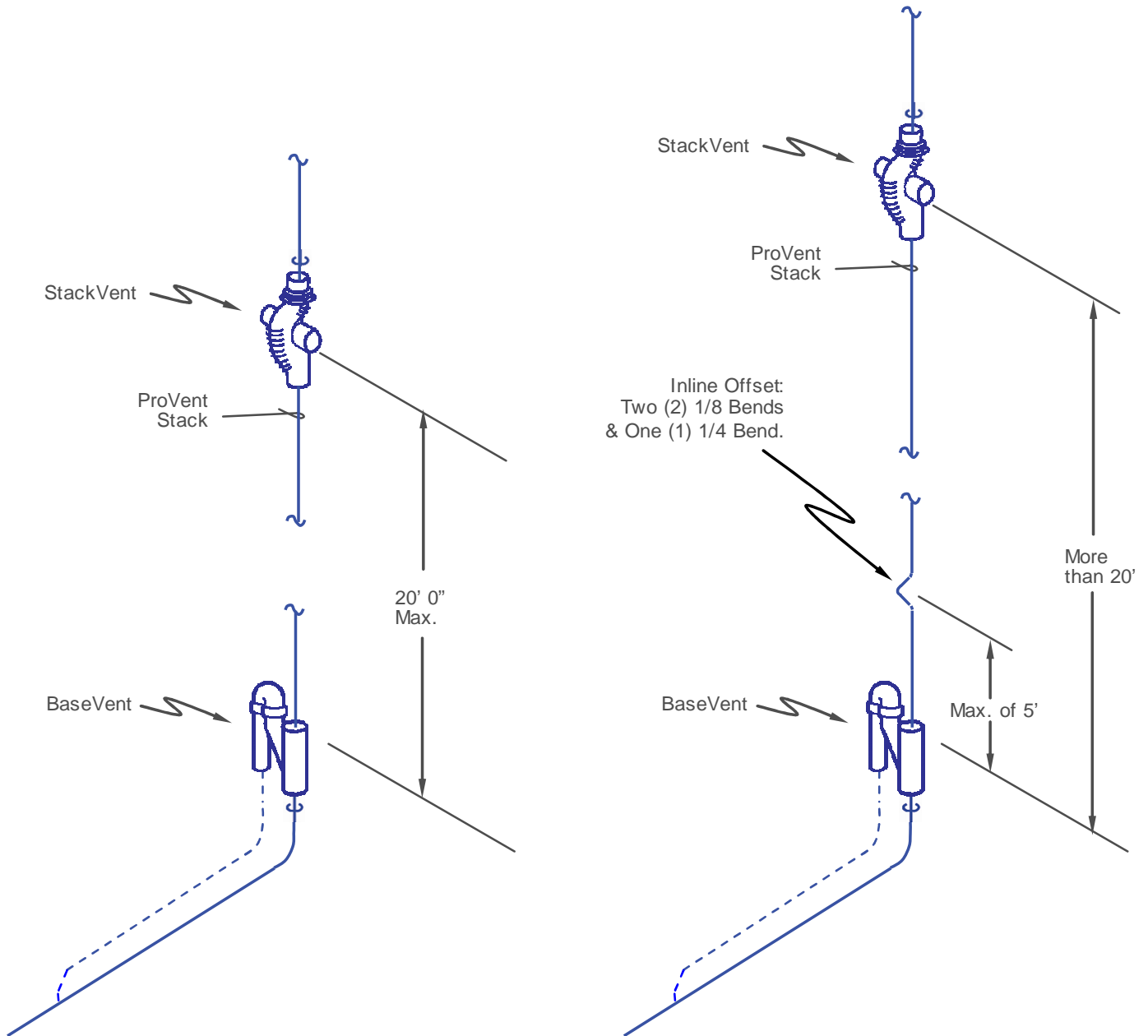

Drawing 2.1



BaseVent Fitting Rule 2.2

The ProVent Base Fitting has a pressure relief vent opening that extends up then makes a 180 degree turn downward using pipe and fittings that connect to the horizontal building drain at a point no less than 10 pipe diameters downstream from the center line of the vertical stack to the centerline of the branch wye. The pressure relief vent line may run parallel to the horizontal drain and must connect above the centerline of the drain. Branch soil or wastes are allowed when they are connected above the horizontal drain line.

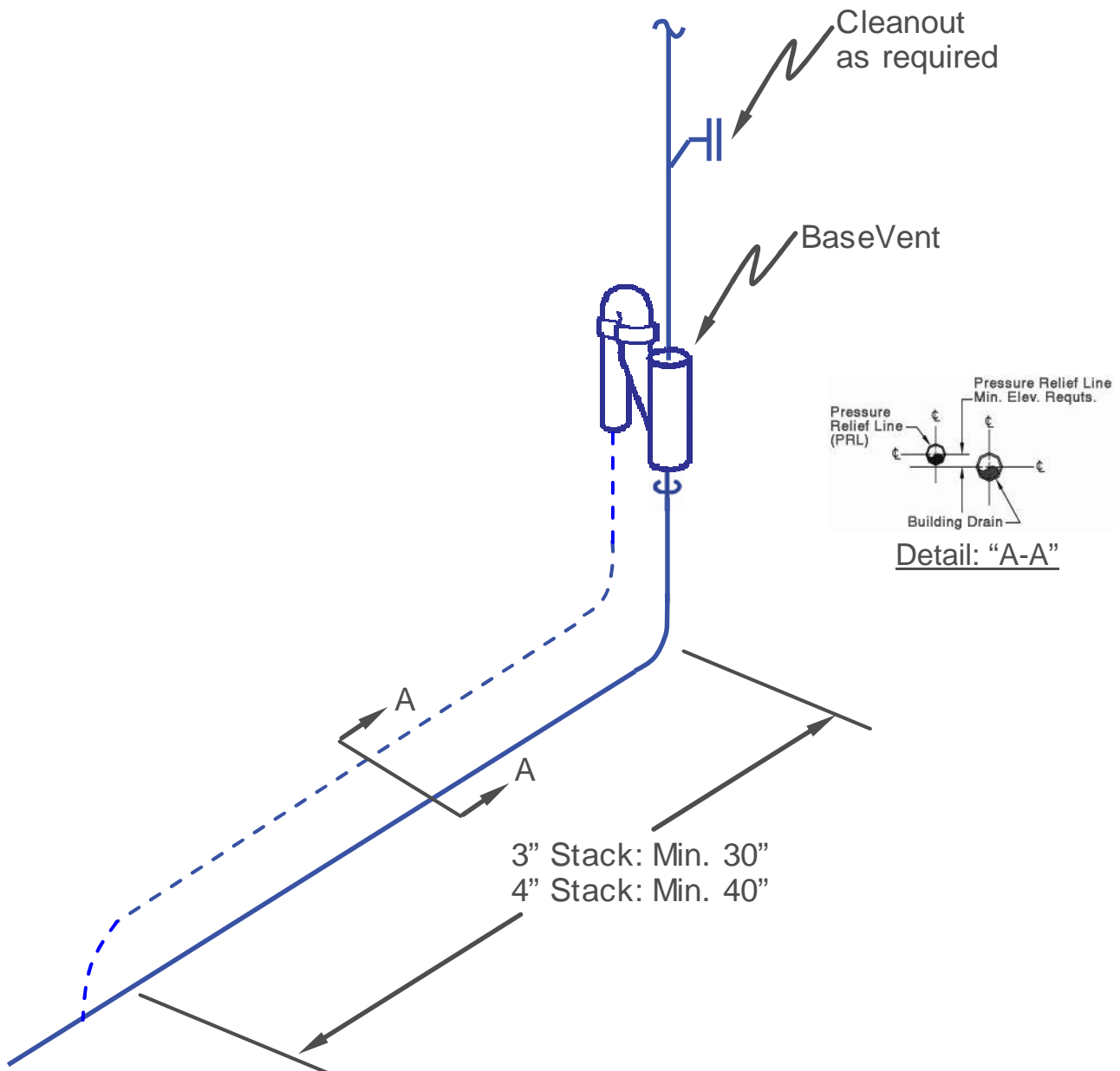

Drawing 2.2



BaseVent Fitting Rule 2.3

A ProVent Base Fitting must be used on any stack offsets of more than 60 degrees with the pressure relief vent connection running from the base fitting back into the top vertical portion of the stack drop.

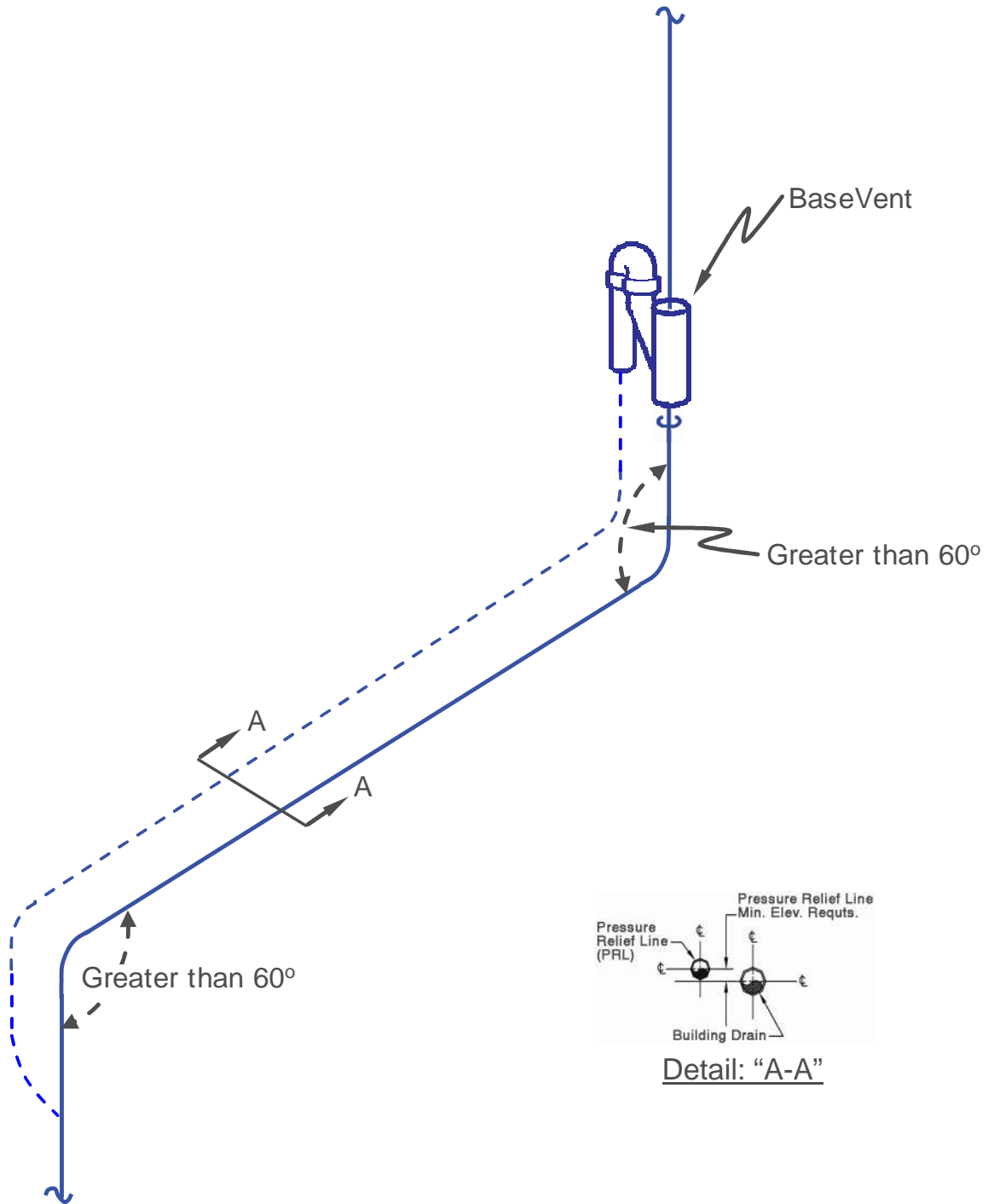

Drawing 2.3

BaseVent Fitting Rule 2.4

Soil and waste branches can be connected into the building drain between the stack and the relief vent when the connections are made above the center line of the building drain. The branch fixture unit loading should be in accordance with the pitch of the pipe as shown in Chart 3.

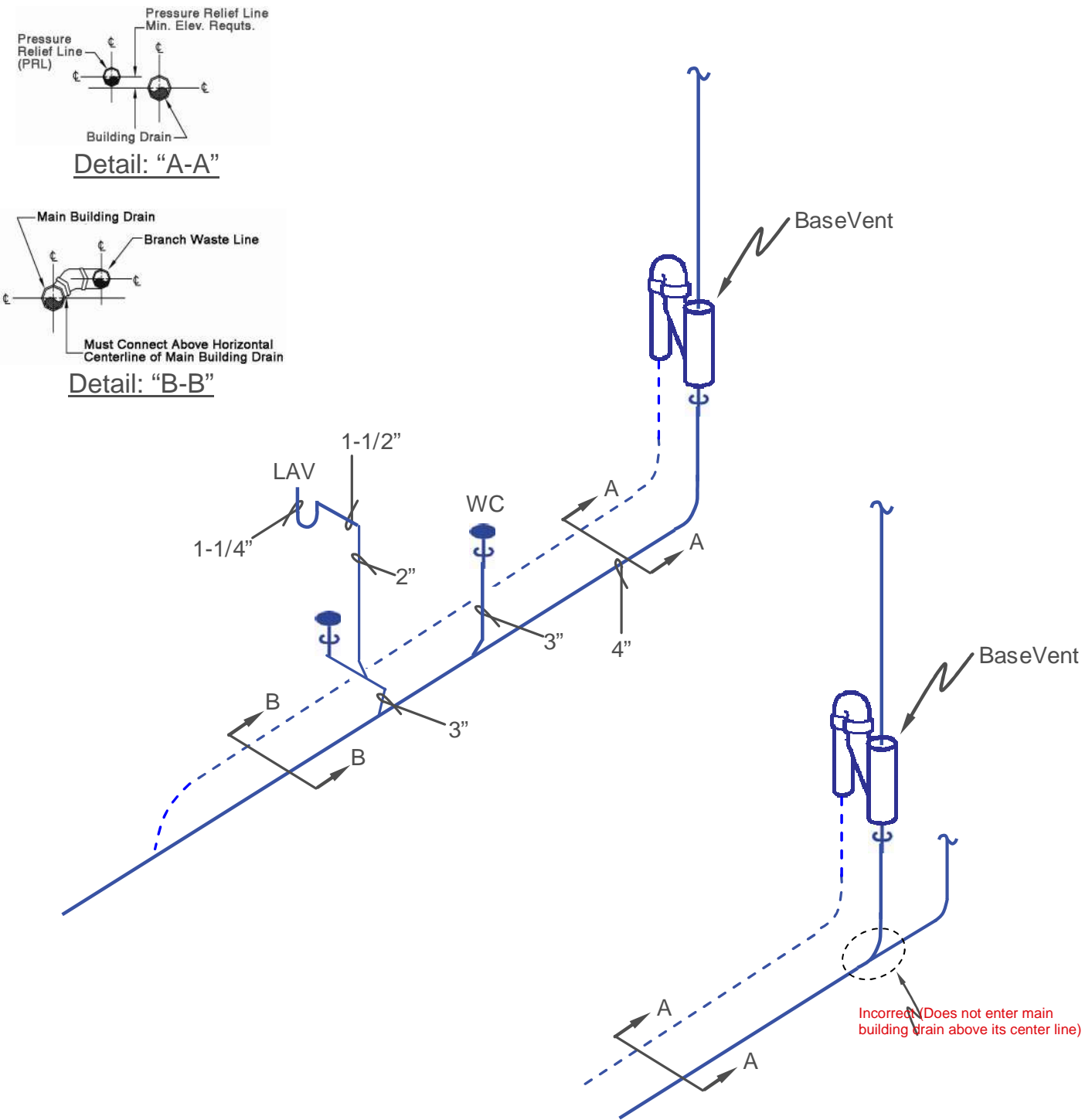

Drawing 2.4



BaseVent Fitting Rule 2.5

Waste branches at least (1) one pipe size smaller can be connected to the pressure relief horizontal vent line. Washing machine drains should not connect to the pressure relief vent line.

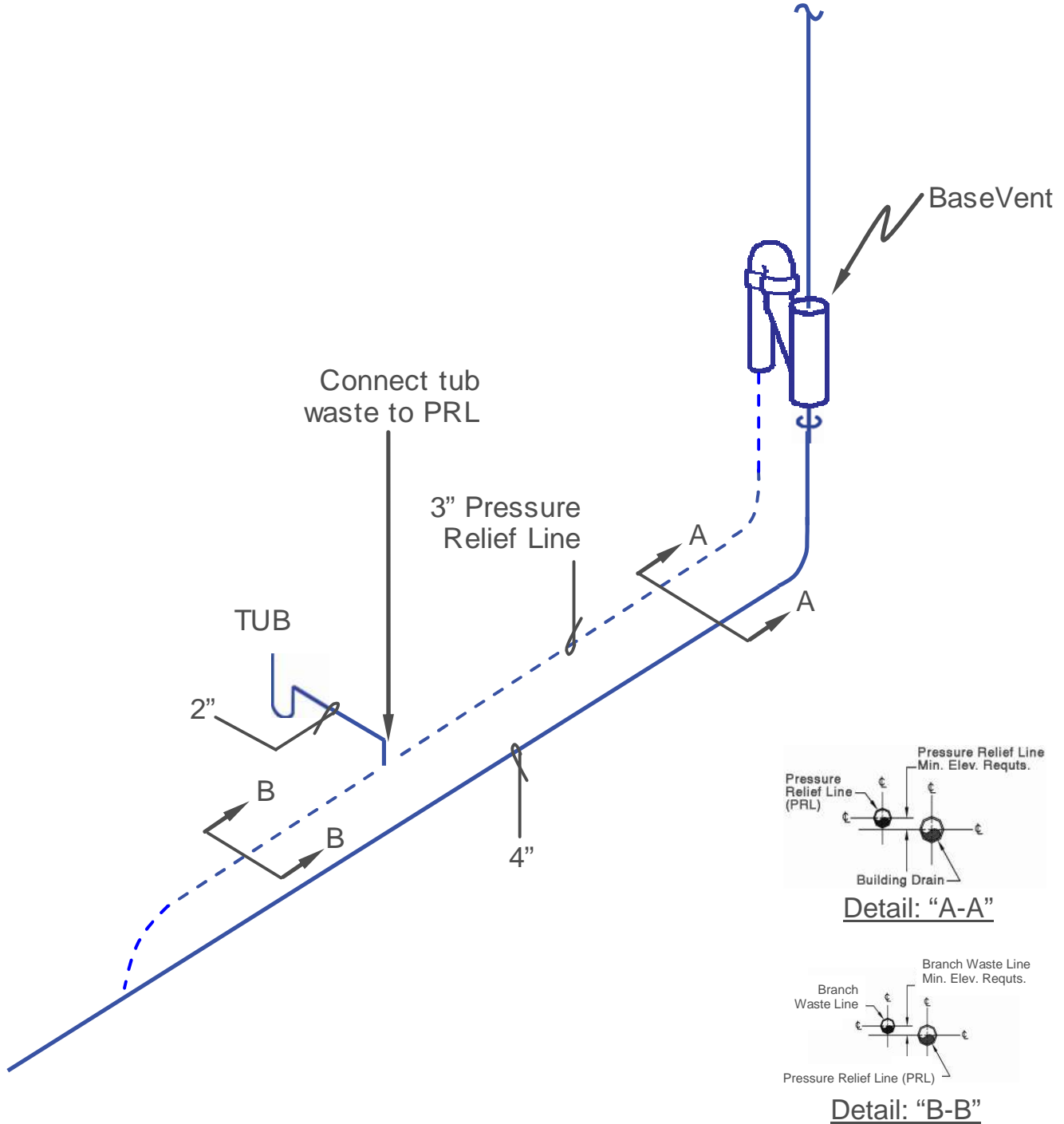

Drawing 2.5



BaseVent Fitting Rule 2.6

Soil or waste branches may connect directly into the vertical stack directly below the ProVent Base Fitting only when the connections are made using fittings such as a combination wye and 1/8 bend.

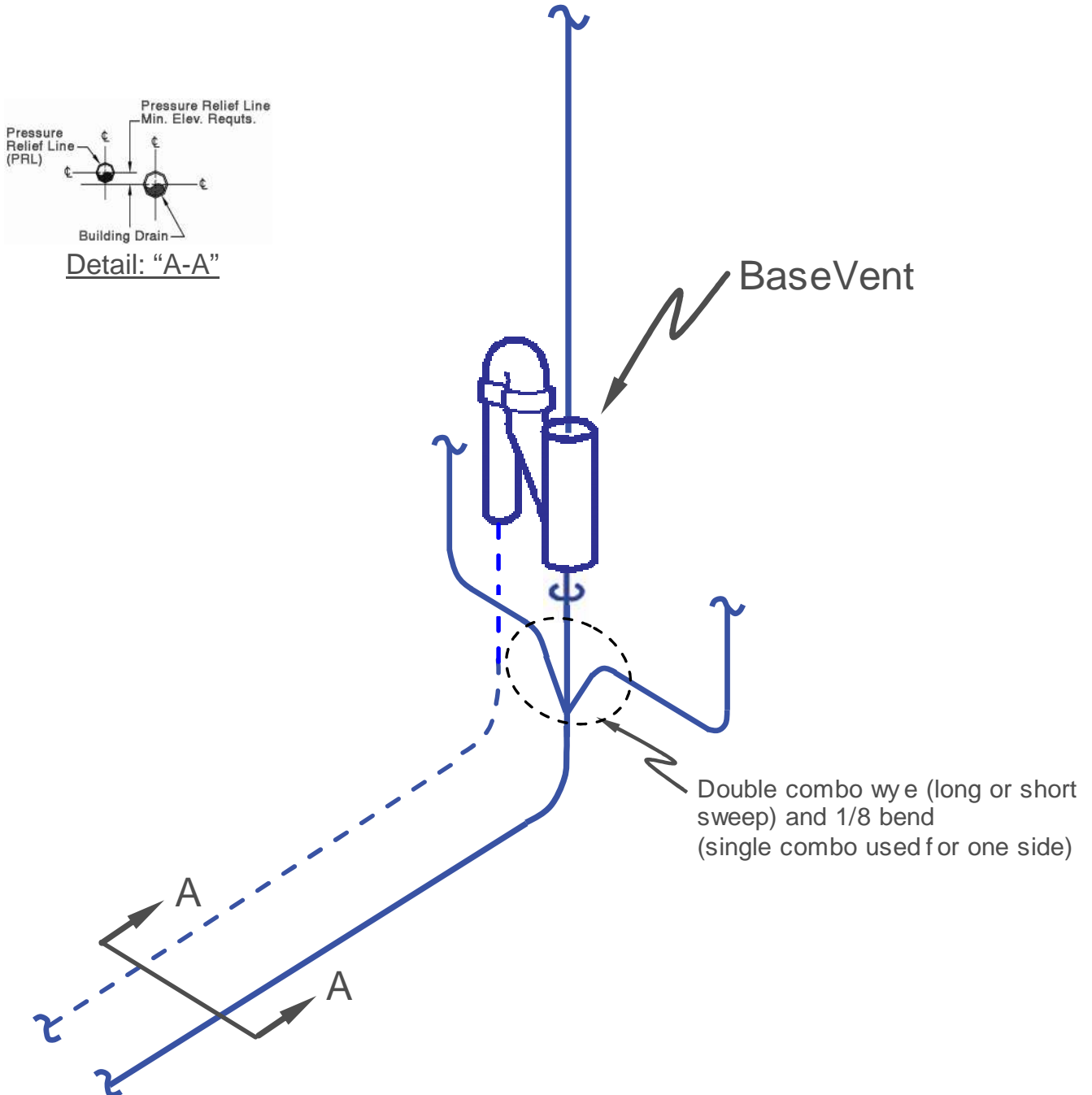

Drawing 2.6



Branch Opening Rule 3.1

All branch piping sizes and loads should be in accordance with Chart 2. Branch piping should have a minimum of 1/8" per foot pitch.

(See Chart 2)

Branch Opening Rule 3.2

Branches that change directions three (3) times by 90 degrees should increase one pipe size at the offset nearest the stack. This increase does not apply if one (1) of the changes can be made with two (2) forty five degree fittings or a long sweep 90 degree fitting.

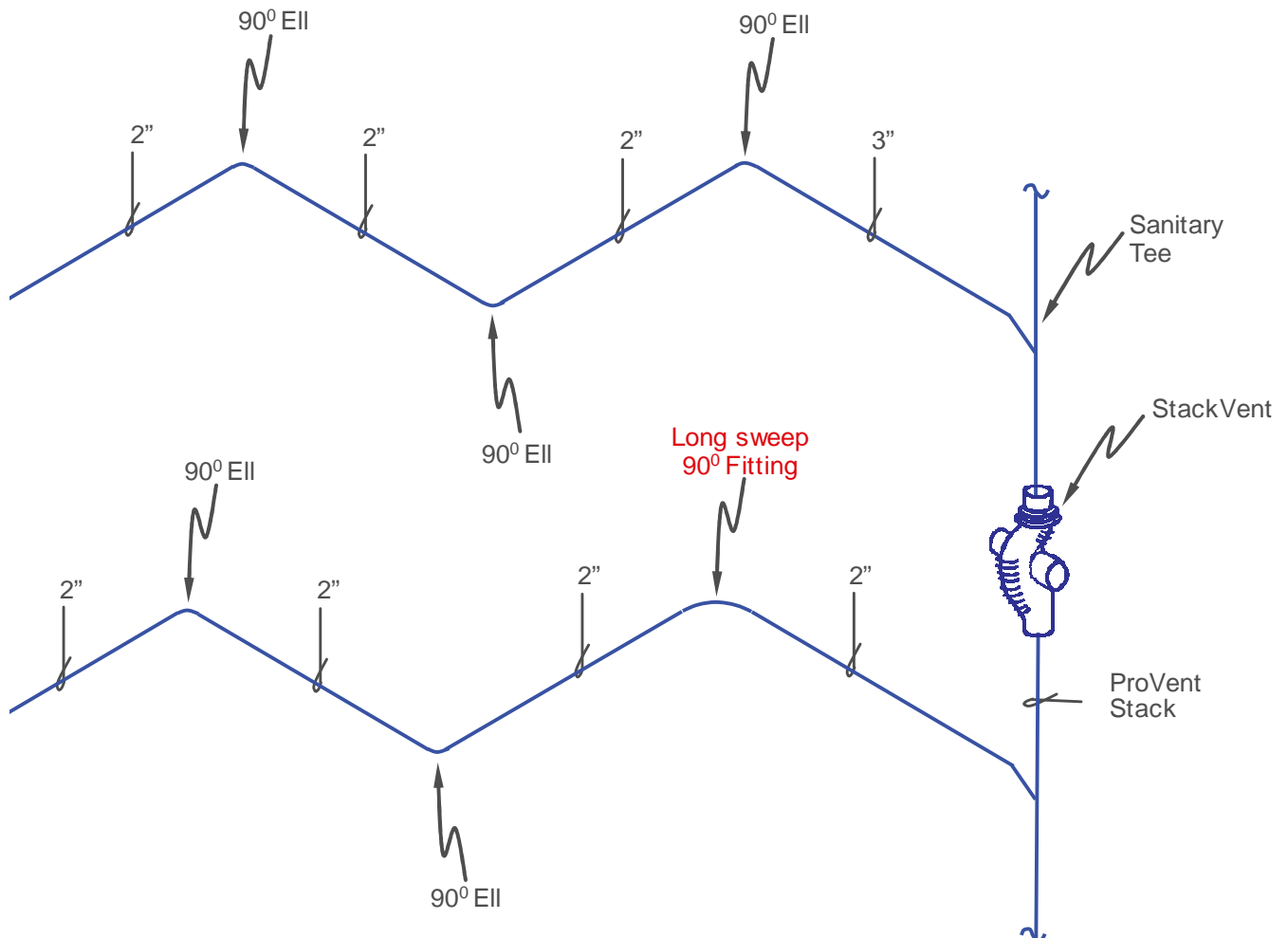

Drawing 3.2

Branch Opening Rule 3.3

If two (2) 3.5 gpf public water closets are connected to the same branch, the first connection can be 3" then increased to 4" at the second connection. This increase is not required for the 1.6 gpf flush water closets. Check manufacturers installation instructions for pressure assisted type water closets that may require special fittings for back to back installations.

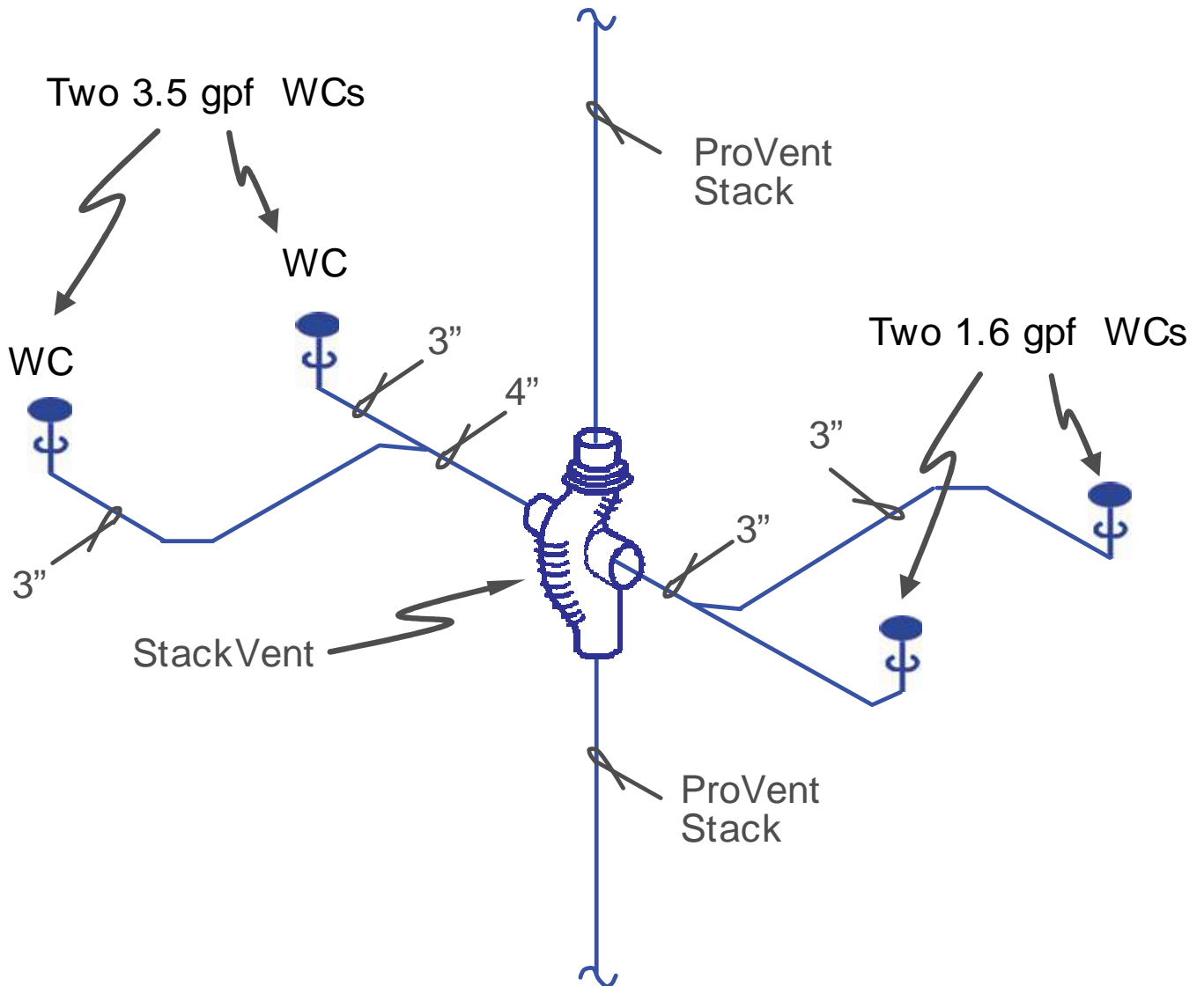

Drawing 3.3

Branch Opening Rule 3.4

4" Size branches shall not exceed a developed length of 27 feet. 3" Size branches shall not exceed a developed length of 15 feet. 2" Size branches shall not exceed a developed length of 15 feet. 2" branches for washing machines should not exceed 5 feet. These lengths include any horizontal pipe offsets but the length of the vertical drop arms is not included (see Rule 3.5 for restrictions on vertical drops). Horizontal to horizontal branch connections should be made with wye combinations or heel outlet fittings.

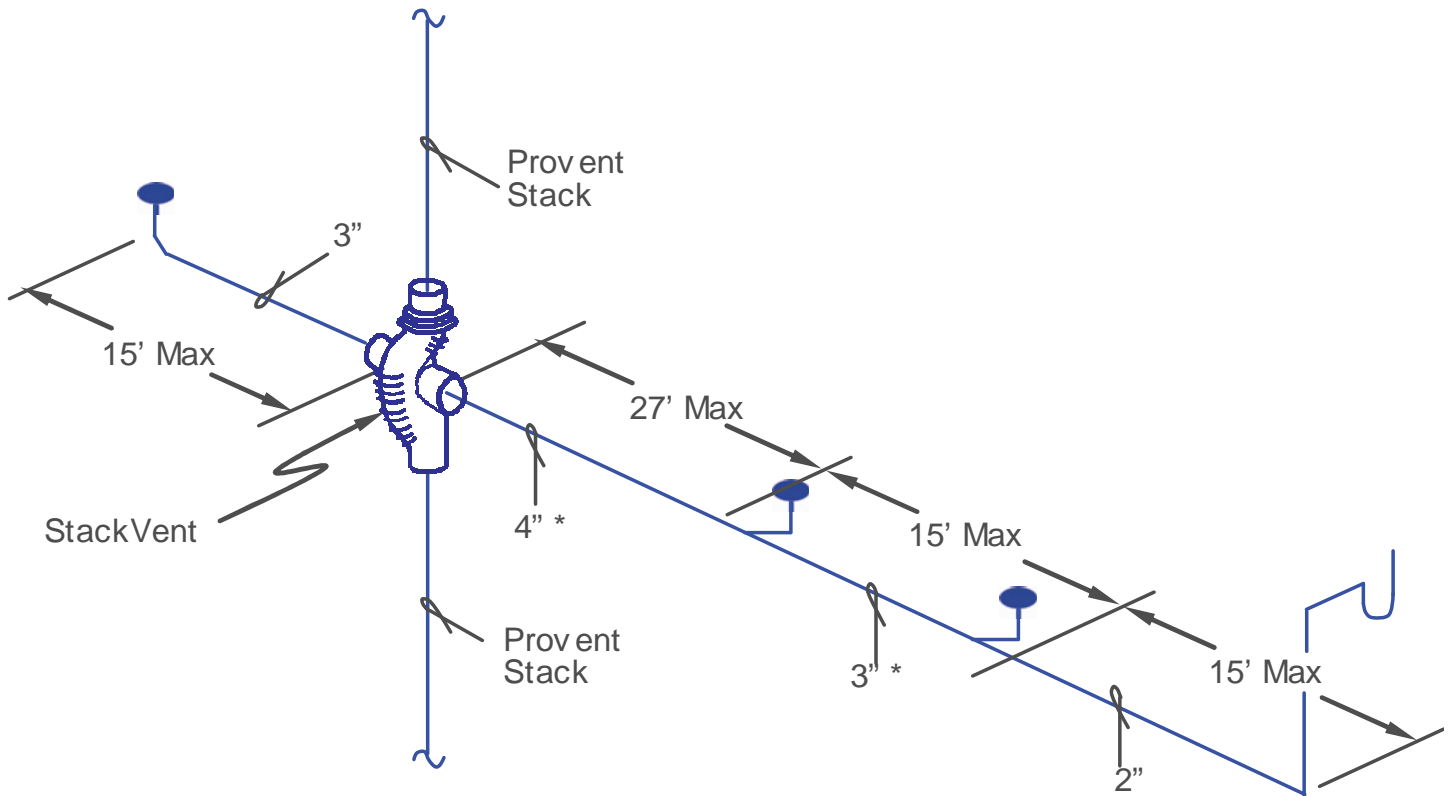

* A maximum distance of 27 ft. is allowed on a 4" soil branch. However, it is recommended that the use of 3" pipe be maximized for 1.6 GPF toilet systems.

Drawing 3.4



Branch Opening Rule 3.5

Vertical branches should not exceed 40". A 45 degree offset can extend the drop pipe to 40" from the top 45 degree fitting to the fixture outlet. When a vertical drop into a horizontal waste exceeds 10 feet both must increase one (1) pipe size.

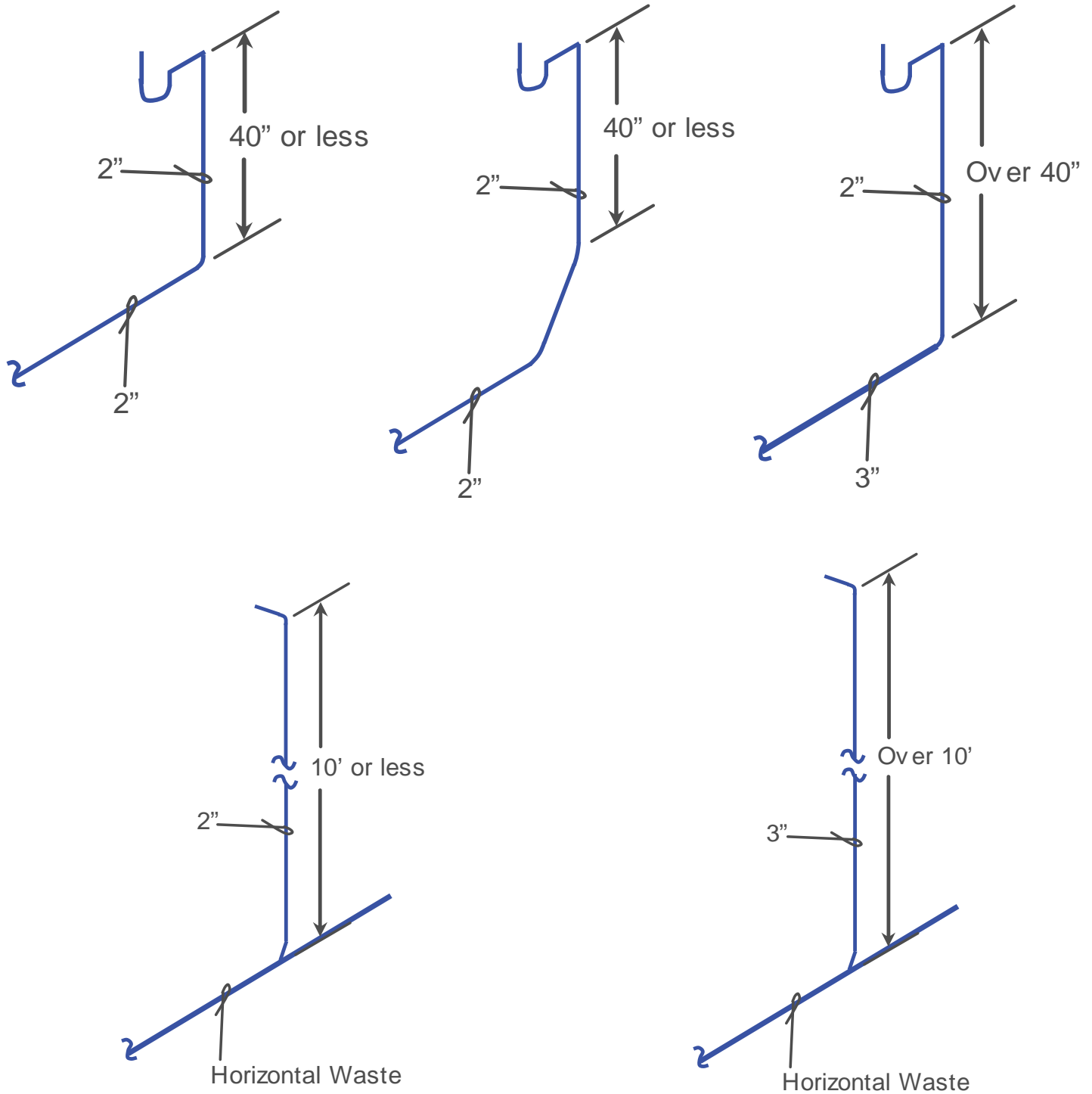

Drawing 3.5

Branch Opening Rule 3.6

1-1/4" size fixture traps can be connected back to back into one 2" vertical drop. 1-1/2" size fixture traps require separate 2" drops. 1-1/2" and larger traps can use a single vertical drop by increasing the drop one (1) pipe size. Note: Horizontal waste branches without vertical drops are sized per chart 2.

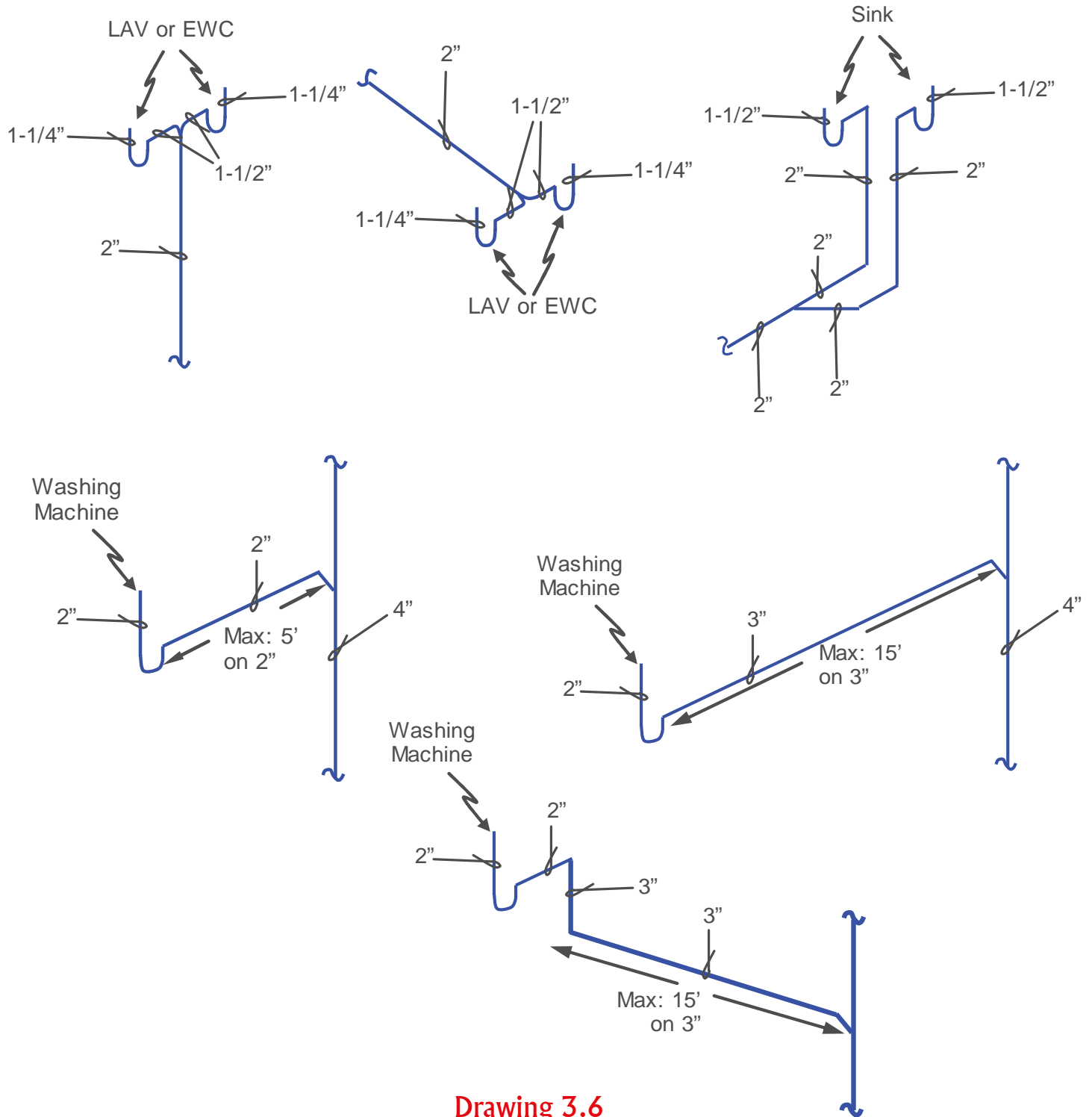

Drawing 3.6



Branch Opening Rule 3.7

An alternate to increase developed lengths can be done by using a revert line or by telescoping smaller to larger pipe sizes or by using an Air Admittance Valve where applicable and permitted. The revert line shall be routed vertically and horizontally and tie in above the flood rim level using a wye branch looking up.

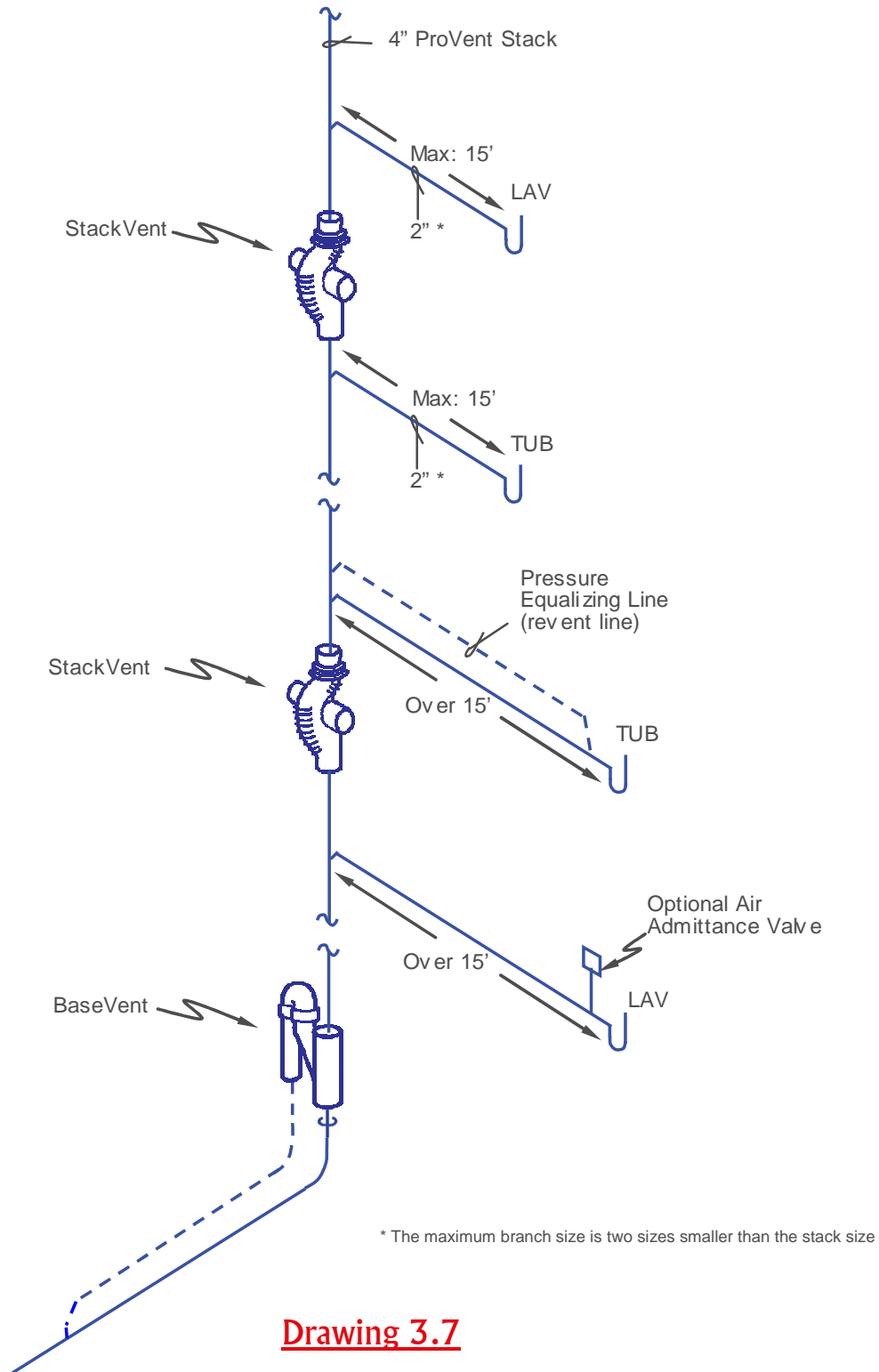

Drawing 3.7



Other Examples of ProVent Fixture Branches

Lavatories: Vertical Branch

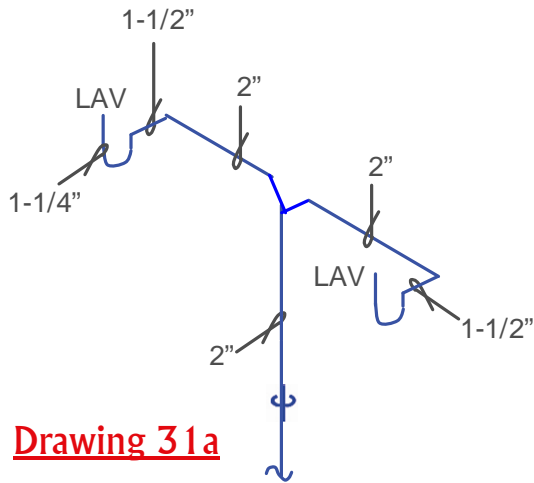

Drawing 31a

Lavatories: Horizontal Branch

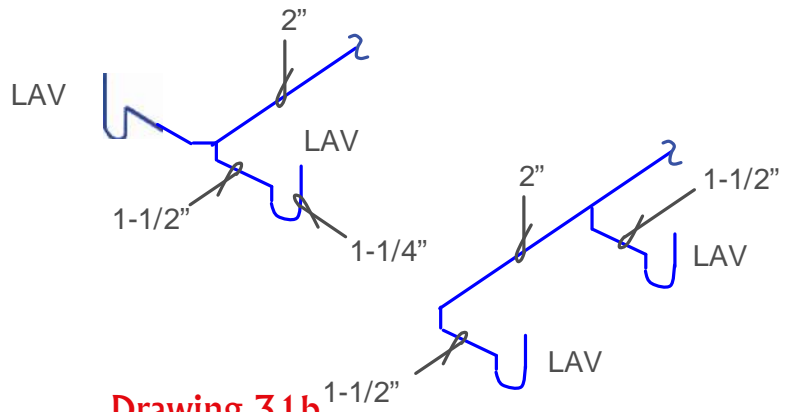

Drawing 31b

Sinks: Vertical Branch

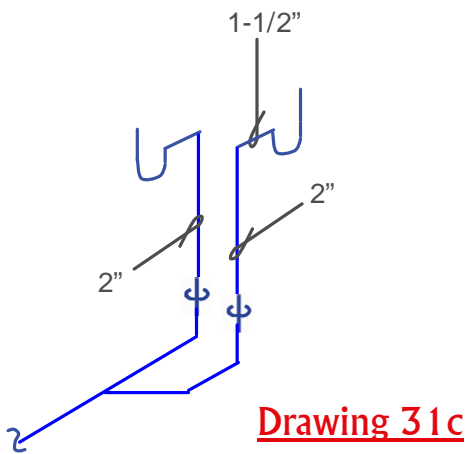

Drawing 31c

Sinks: Horizontal Branch

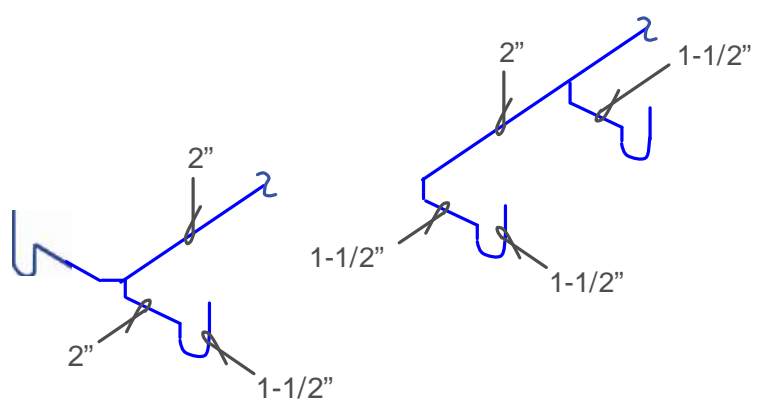

Drawing 31d

Washing Machines: Vertical Branch

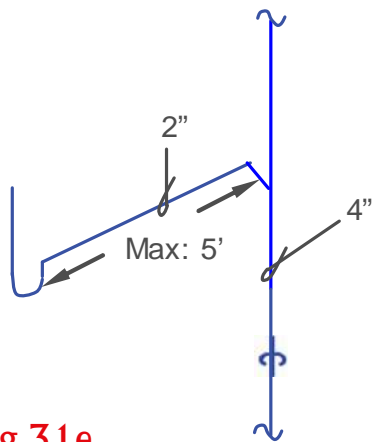

Drawing 31e

Washing Machines: Horizontal Branch

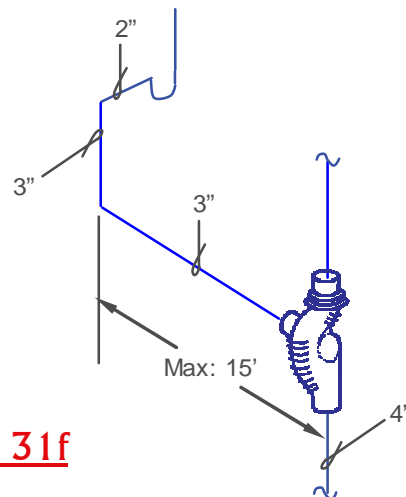

Drawing 31f



Example: Side by Side Layouts

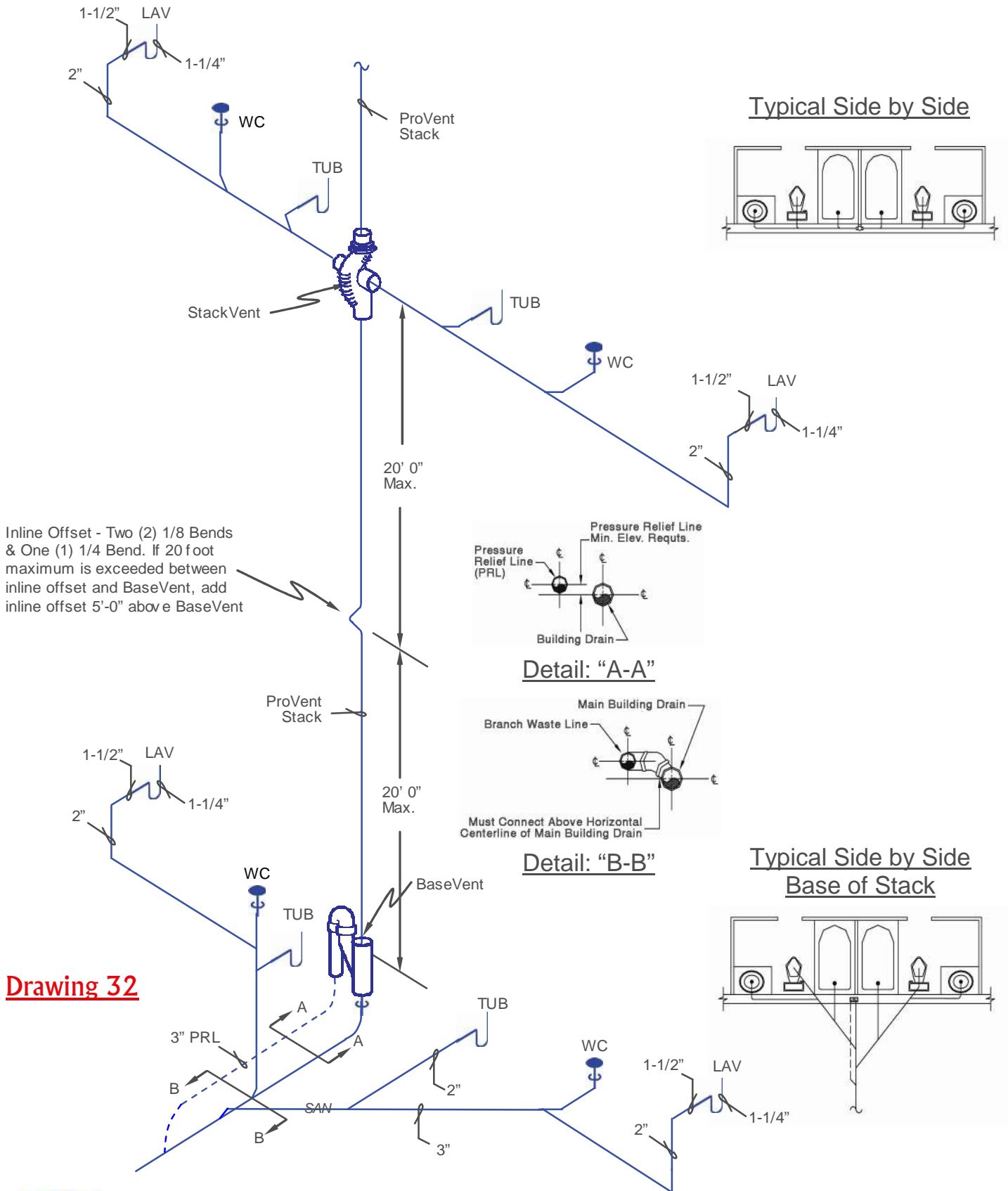

Drawing 32



Example: Single Unit Layouts

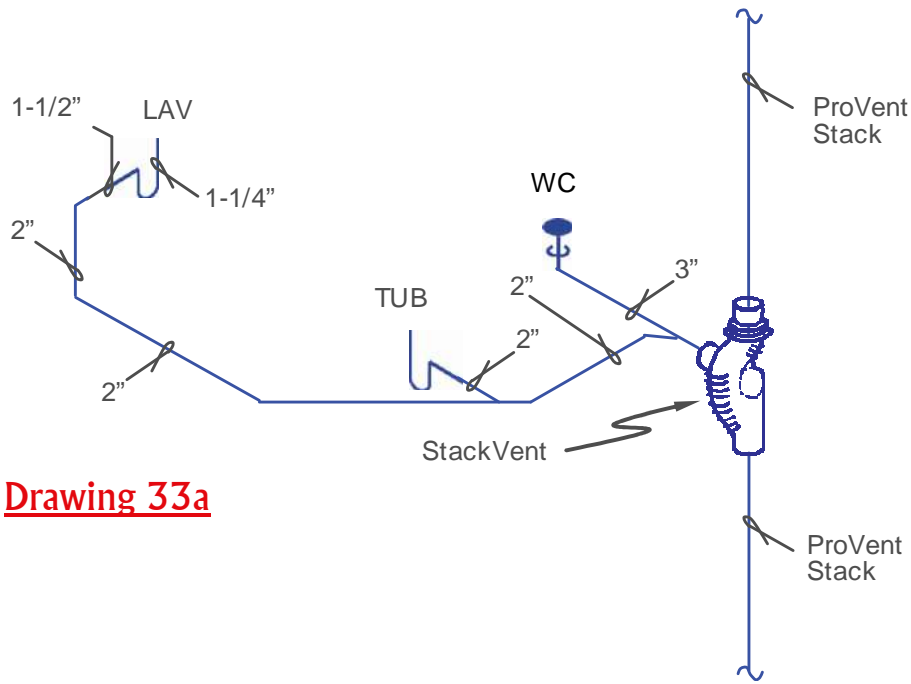

Typical Single Unit

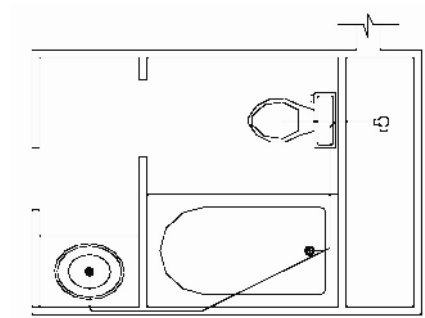

Drawing 33a

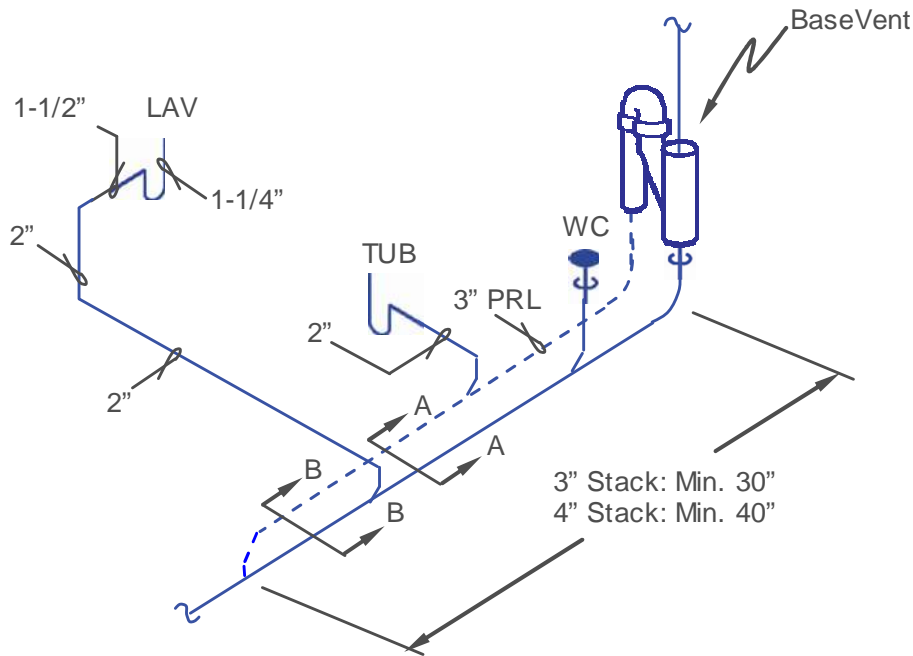

Typical Single Unit
Base of Stack

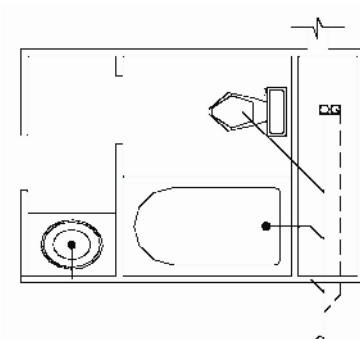

Drawing 33b

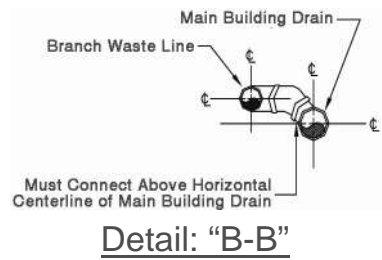
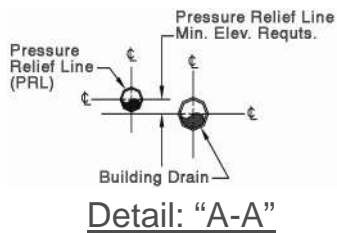

Example 1: Back to Back Layouts

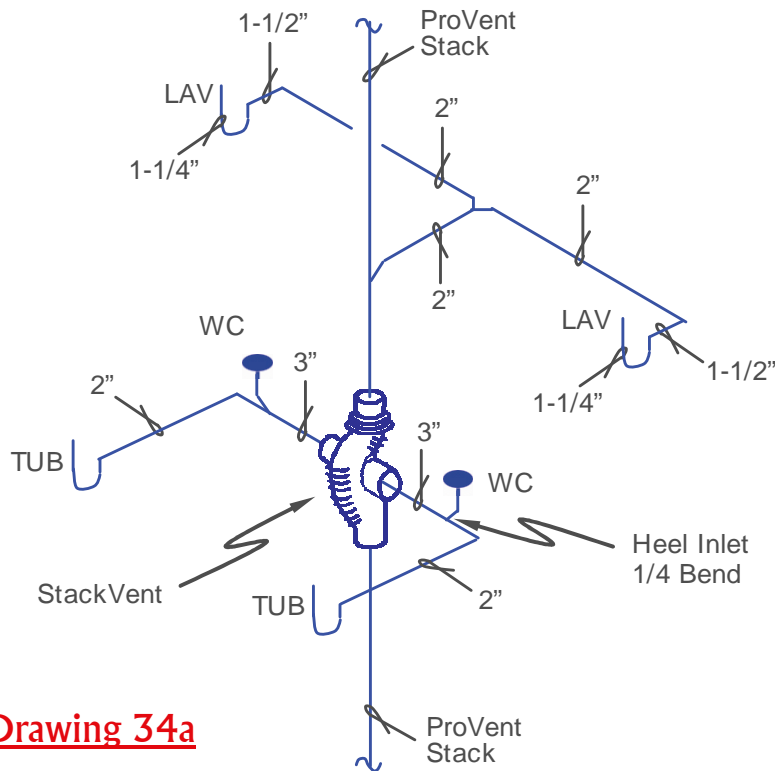

Drawing 34a

Typical Back to Back

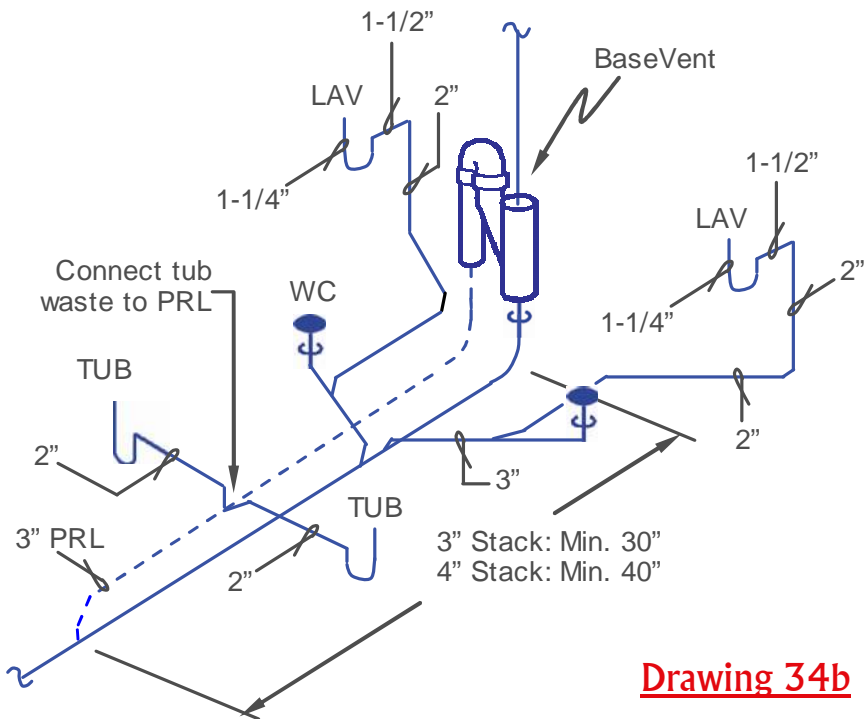
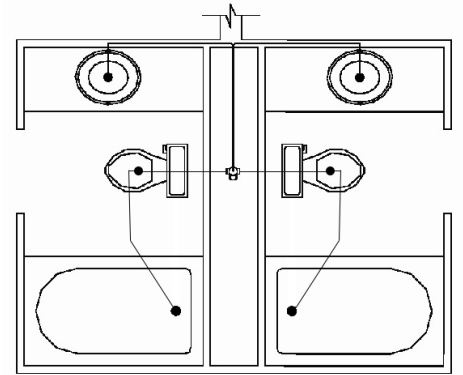

Drawing 34b

**Typical Back to Back
Base of Stack**

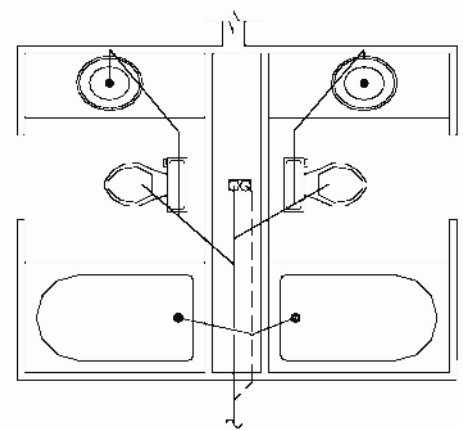

Example 2: Back to Back Layouts (Alternative Layout for Upper Floors)

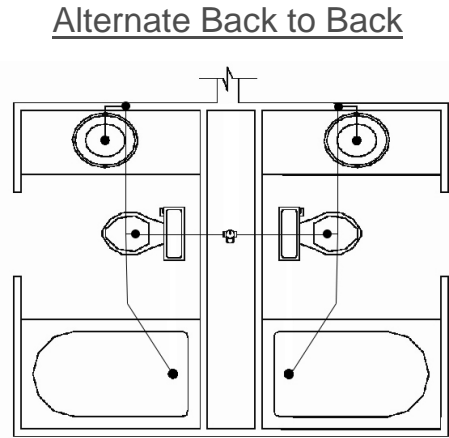
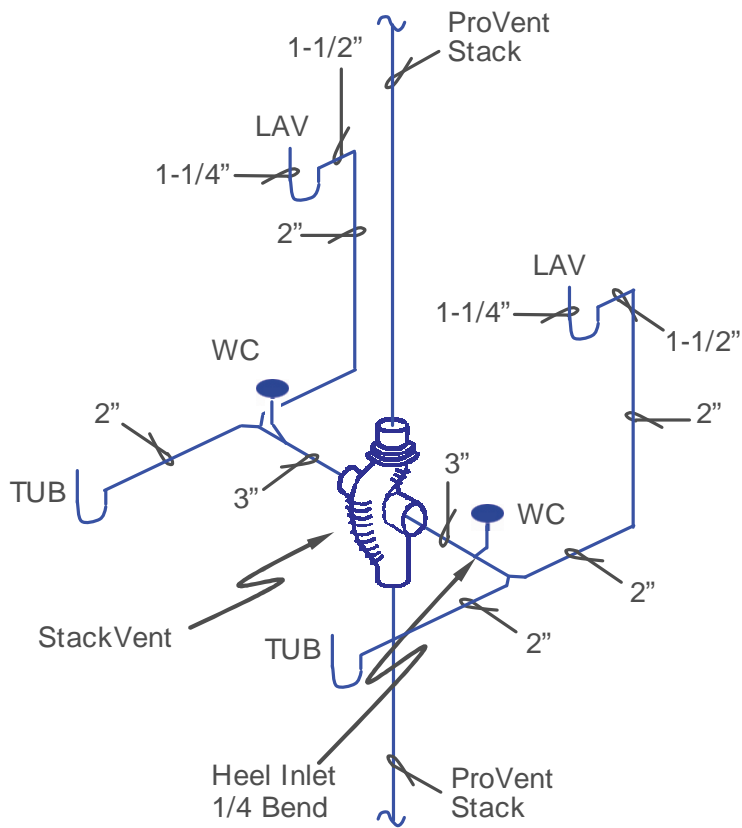

Drawing 34c

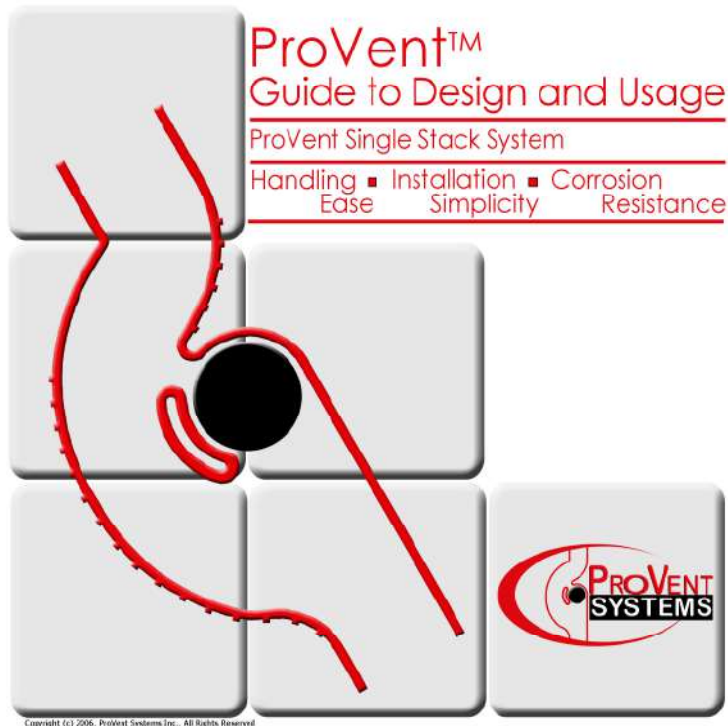

IMPORTANT NOTICE

This manual shows the basic plumbing rules that have been used for over 40 years for both the copper and cast iron Sovent systems. The same rules apply for this PVC plastic ProVent System that includes both the ProVent Stack and Base fittings.

ProVent Systems may include conventional plumbing that must be installed in accordance with local plumbing codes. The vents from conventional plumbing may be tied into the ProVent stack as indicated within this manual.

ProVent Systems can assist in job design and inspections under certain understood conditions with the contractor or plumbing engineer. Job quotations may or may not include these services where required. Contact us for further information.

All additional piping, fittings, pipe supports, firestopping and other items that are supplied by others, should be in strict accordance with good piping practices and all applicable codes having jurisdiction.

When the rules used in this manual are adhered to without any deviations the system is known to function properly. However, any unknown deviation may reduce the integrity of this system. Therefore, the user must assume all responsibility for the integrity and performance of the completed DWV plumbing system and for adherence to all the rules included in this manual.

ProVent Systems cannot assume responsibility for the performance of the complete DWV system other than for the performance of the individual components supplied by ProVent Systems, as stated in the "Limited Parts Warranty", below.

LIMITED PARTS WARRANTY

Sellers products are carefully inspected for manufacturing defects; however, it is not always possible to detect hidden defects. Said products are warranted only to the extent that seller will replace without charge, products proved to have manufacturing defects within 6 months of the date of delivery thereof and provided seller has been given an opportunity to inspect the product alleged to be defective and the installation or use thereof. NO WARRANTY IS INCLUDED AGAINST ANY EXPENSE FOR REMOVAL, REINSTALLATION OR OTHER CONSEQUENTIAL DAMAGES ARISING FROM ANY DEFECT. THE WARRANTIES SET OUT ABOVE ARE THE ONLY WARRANTIES MADE BY SELLER AND ARE EXPRESSLY IN LIEU OF ALL OTHER WARRANTIES, EXPRESSED OR IMPLIED, INCLUDING THE WARRANTIES OR MERCHANTABILITY AND FITNESS FOR A PARTICULAR PROPOSE.