



CLASSICA DI BONGIO

1936

GGIO

CLASSICA DI BONGIO

CLASSICA DI BONGIO

CLASS

CLASSICA DI BONGIO

CLASSICA DI BONGIO

CLASSICA DI BONGIO

GGIO

CLASSICA DI BONGIO

CLASSICA DI BONGIO

CLASS

CLASSICA DI BONGIO

CLASSICA DI BONGIO

CLASSICA DI BONGIO

GGIO

CLASSICA DI BONGIO

CLASSICA DI BONGIO

CLASS

CLASSICA DI BONGIO

CLASSICA DI BONGIO

CLASSICA DI BONGIO

CLASSICA DI BONGIO

CLASSICA DI BONGIO

CLASSICA DI BONGIO

CLASSICA DI BONGIO

CLASSICA DI BONGIO

CLASSICA DI BONGIO

CLASSICA DI BONGIO

CLASSICA DI BONGIO

CLASSICA DI BONGIO

CLASSICA DI BONGIO

CLASSICA DI BONGIO

CLASSICA DI BONGIO

VEDUTE PRIVILEGIATE

Grazie alla fortunata storia sia nell'arte che nell'architettura, l'Italia da sempre ha una finestra privilegiata sul mondo delle discipline creative. È da qui che nascono sensibilità, gusto estetico e creatività che contraddistinguono i prodotti made in Italy.

Oggi Bongio consolidato nel prodotto di design, affianca e propone il nuovo progetto 'Classica di Bongio' che nelle intenzioni ripercorre un gusto tradizionale, evocando prodotti di grande pregio e nobiltà dei primi anni del '900.

Certi di stimolare la vostra fantasia nella scelta di una nuova gamma, sempre rispettosa dei nostri standard qualitativi, Vi invitiamo ad affacciarvi alle finestre di questo catalogo.

PRIVILEGED VIEWS

Thanks to its lucky story both in the art and in the architecture, Italy has always enjoyed of a privileged window on the world of the creative disciplines. Sensibility, aesthetic taste and creativity start from here and they distinguish the products made in Italy.

Today Bongio, consolidated in the design product, supports and proposes the new project 'Classica by Bongio', which in its intentions recalls a traditional taste and evokes products of high quality and nobility of the beginning of the 20th century.

Sure to stimulate your imagination in the choice of a new range, always in respect of the quality standard of Bongio company, we invite you to look into the windows of this catalogue.

CLASSICA DI BONGIO

1936

bongio

IMPERO

MADE WITH SWAROVSKI® ELEMENTS

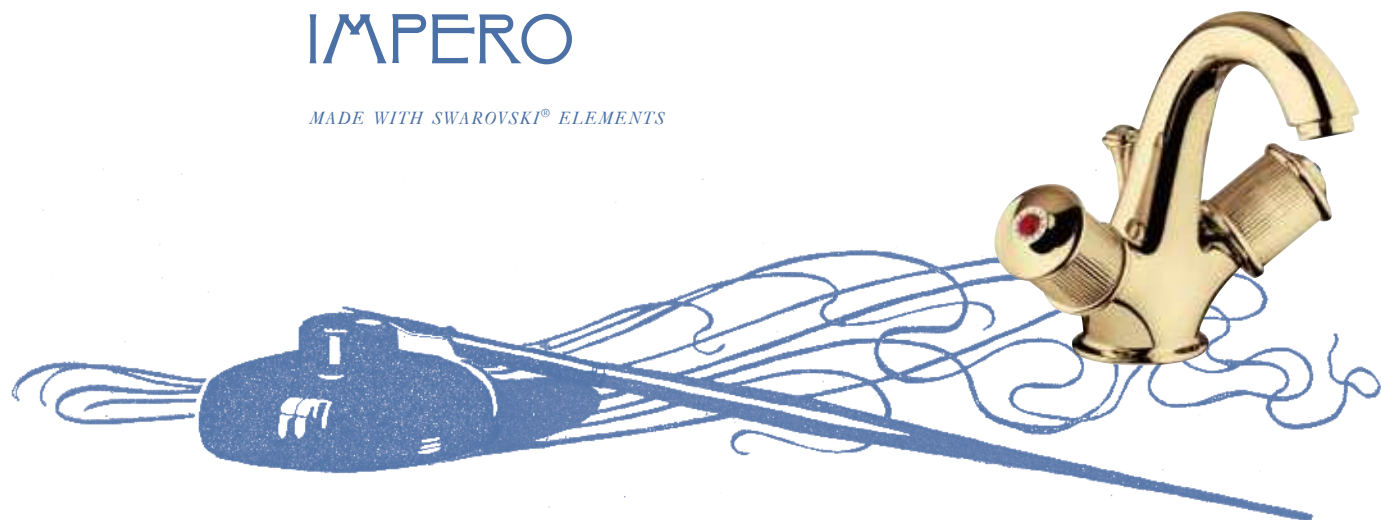

bongio



PALAZZO GRASSI - Venice - Italy





IMPERO

CLASSICA DI BONGIO

CRISTALLO

8

bongio





VILLA NOBEL - San Remo - Italy



CRISTALLO

CLASSICA DI BONGIO



RADIANT

12

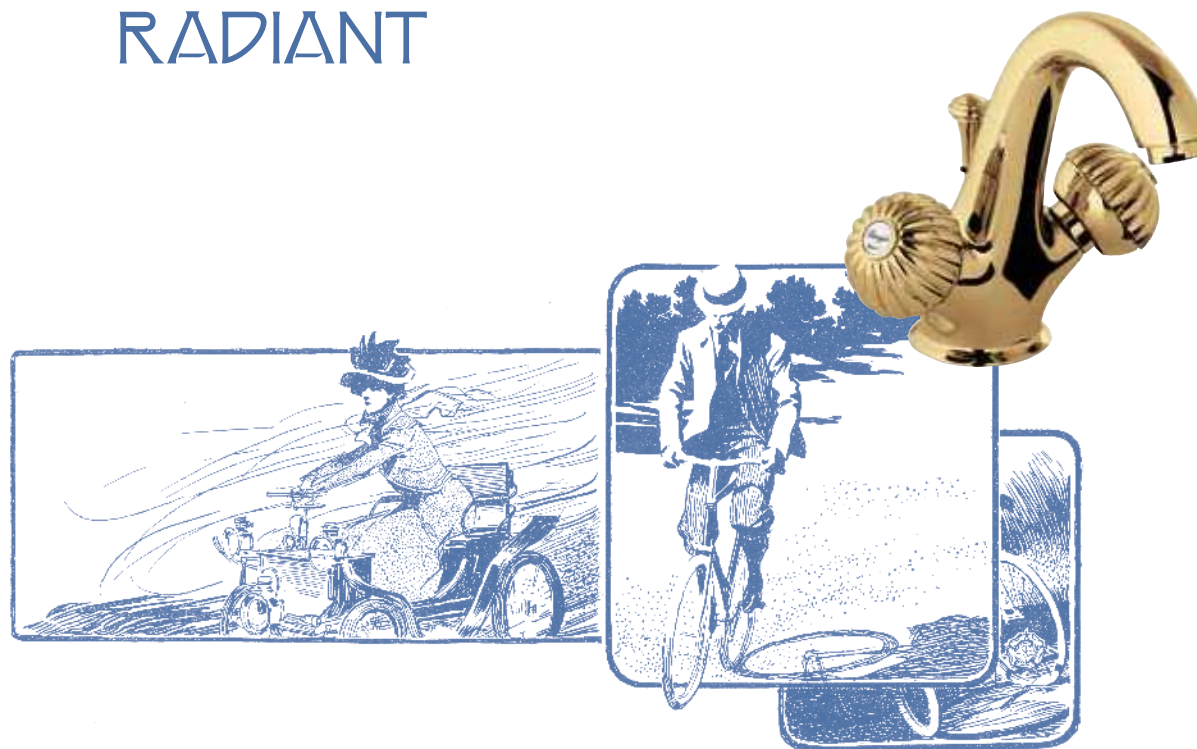

bongio



PALAZZO VECCHIO - Florence - Italy





RADIANT

RIVOLI



bongio



GALLERIA VITTORIO EMANUELE - Milan - Italy



RIVOLÌ

CLASSICA DI BONGIO



FLEUR
BLANC

bongio





REGGIA DI CASERTA - Caserta - Italy

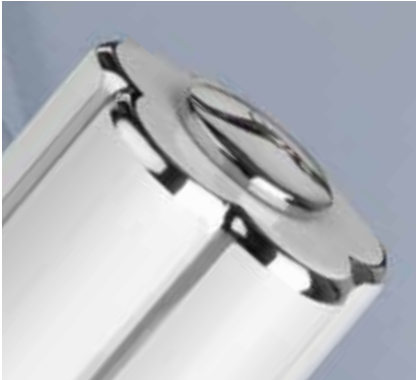



FLEUR BLANC

CLASSICA DI BONGIO

FLEUR
NOIR

24

bongio

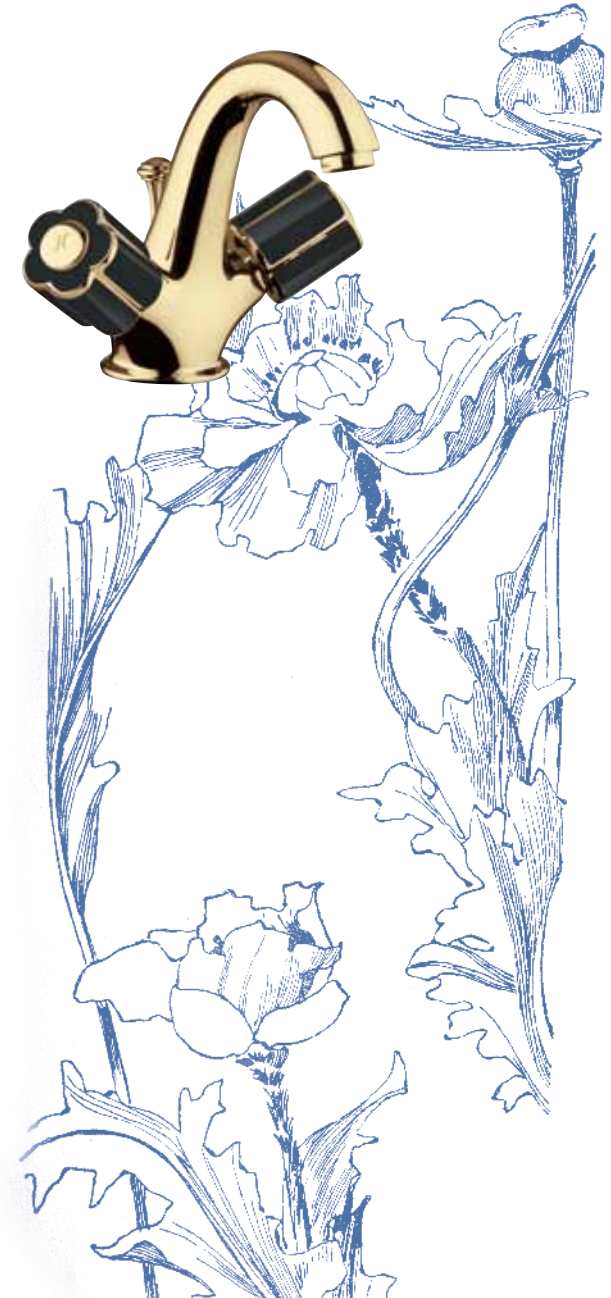



STUPINIGI - Turin - Italy



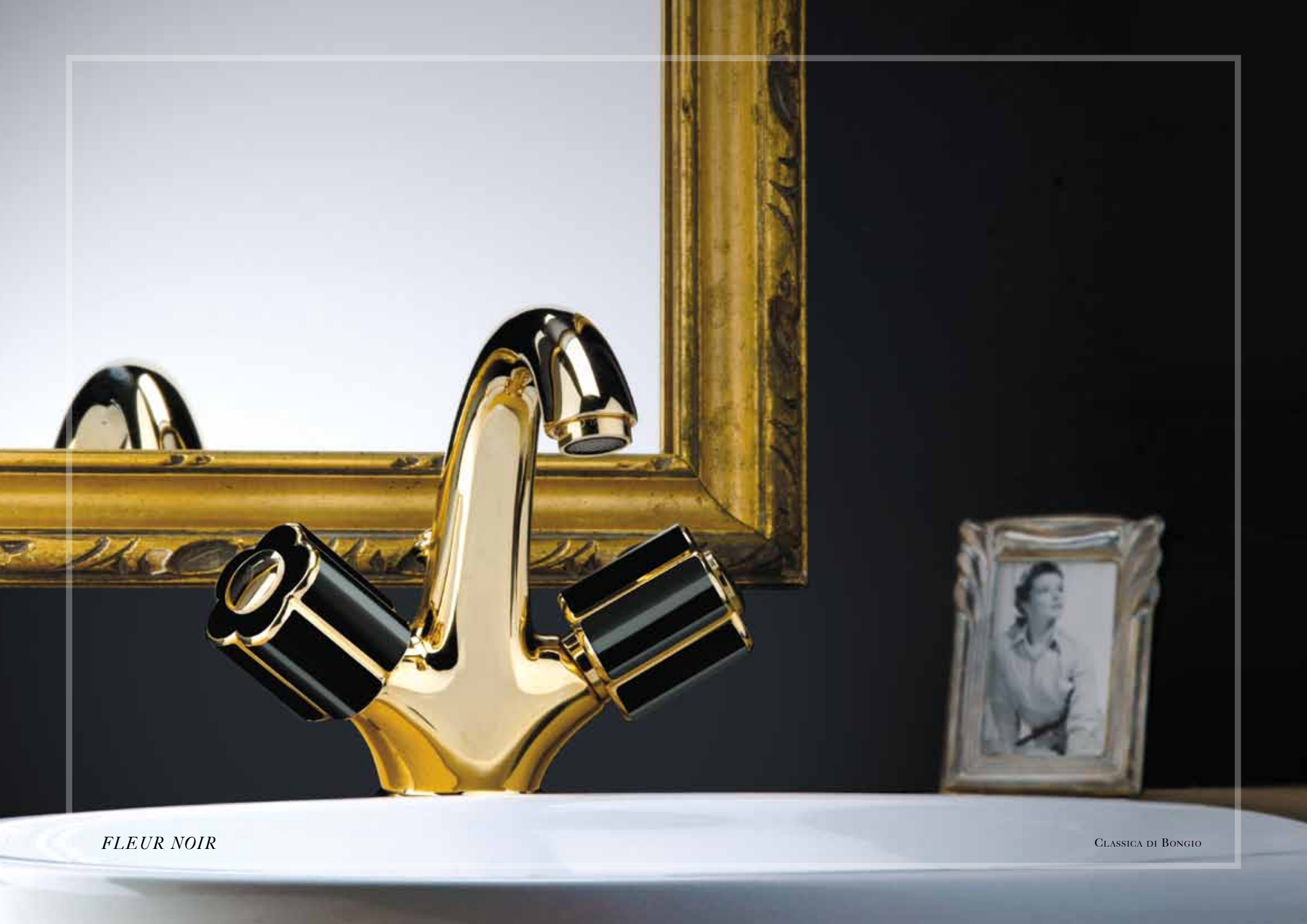

FLEUR NOIR

CLASSICA DI BONGIO

CAPRI

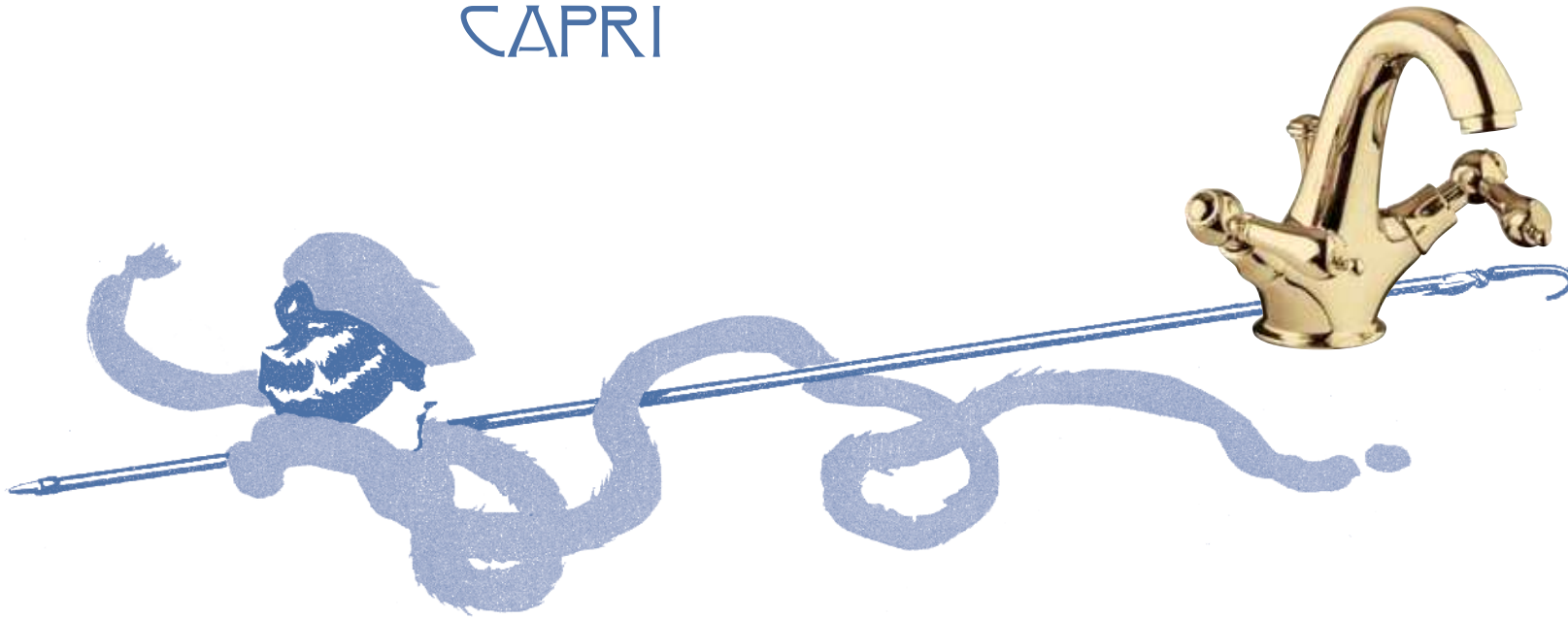

bongio



VILLA MELZI - Bellagio - Italy



CAPRI

CLASSICA DI BONGIO



AXEL



bongio



VILLA CAPRA - Valmarana - Italy





AXEL

CLASSICA DI BONGIO

COCO

bongio





VILLA DORIA PAMPHILJ - Rome - Italy





cocò

CLASSICA DI BONGIO

OXFORD LUX

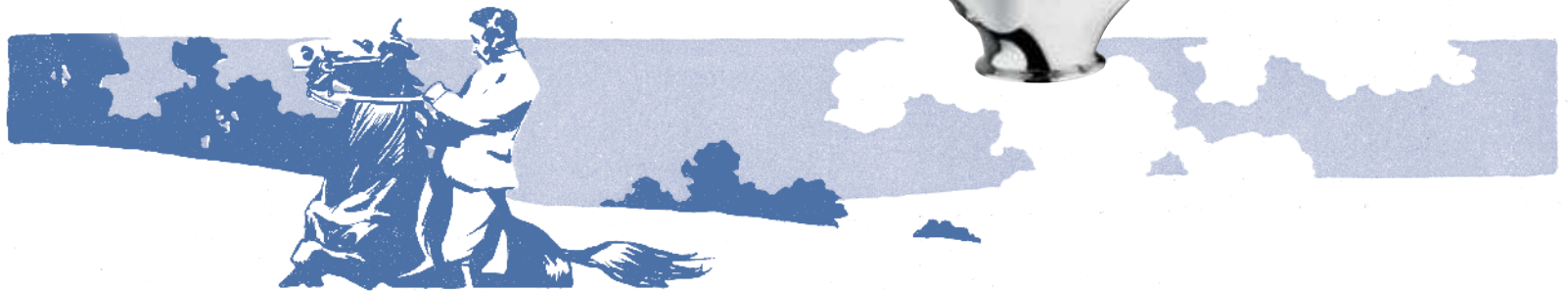

bongio



VILLA TORRIGIANI - Lucca - Italy



OXFORD LUX

CLASSICA DI BONGIO



MILLE NUITS

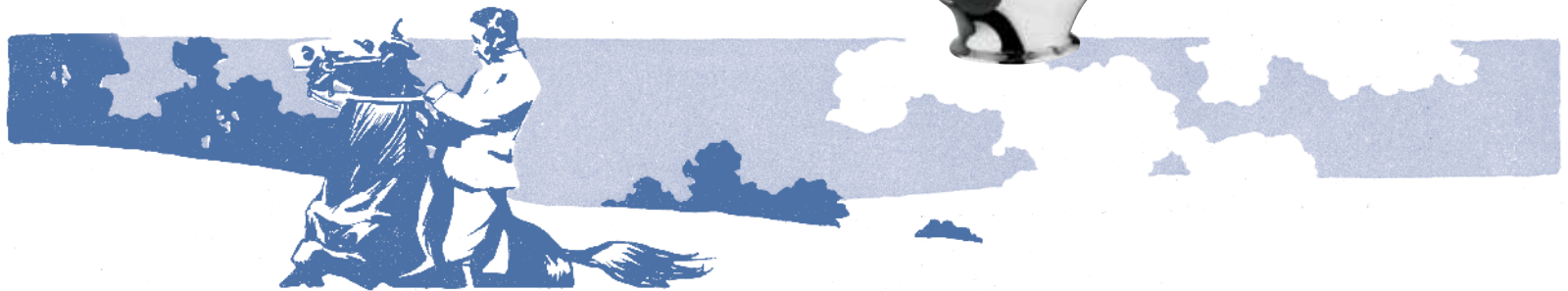

bongio



VILLA PISANI - Riviera del Brenta - Italy



MILLE NUITS

CLASSICA DI BONGIO



MILLE NUTS

CLASSICA DI BONGIO

ZENITH

MADE WITH SWAROVSKI® ELEMENTS

48

bongio

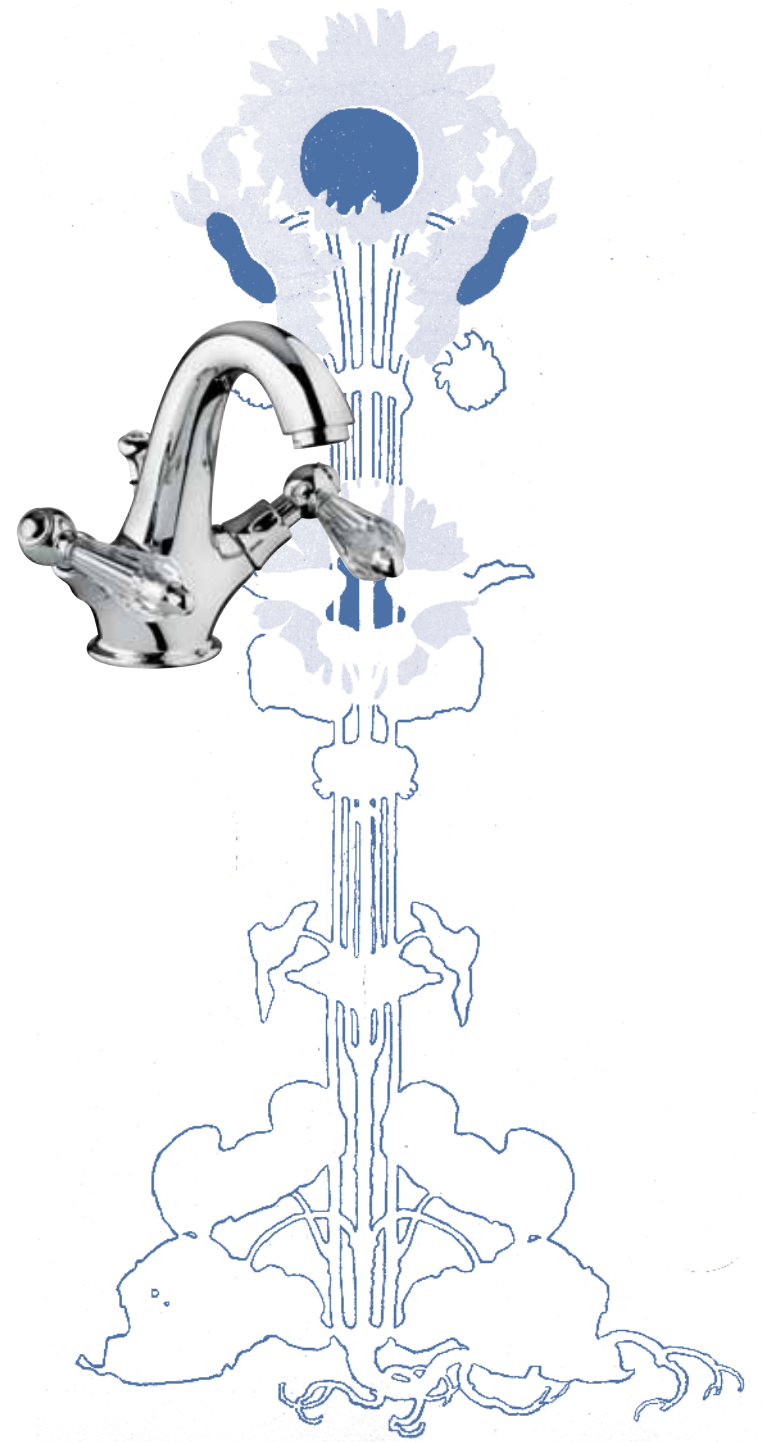



VILLA OLMO - Como - Italy



ZENITH

CLASSICA DI BONGIO

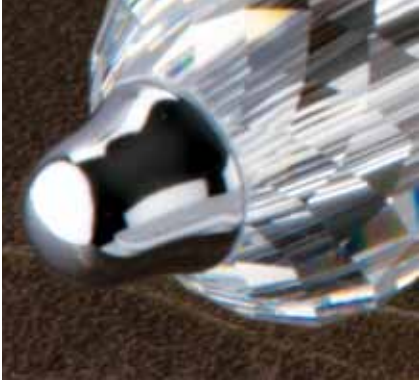

CLASSICA DI BONGIO

SEZIONE TECNICA
TECHNICAL SECTION



IMPERO
PAG. 54



CRISTALLO
PAG. 60



RADIANT
PAG. 66



RIVOLÌ
PAG. 72



FLEUR BLANC
FLEUR NOIR
PAG. 78



CAPRI
PAG. 84



AXEL
PAG. 90



COCÒ
PAG. 96



OXFORD LUX
MILLE NUITS
PAG. 102



ZENITH
PAG. 108



ACCESSORI
ACCESSORIES
PAG. 114



DOCCE &
COMPLEMENTI
SHOWER & COMPLEMENTS
PAG. 125

IMPERO

MADE WITH SWAROVSKI® ELEMENTS





06501

Batteria lavabo tre fori completa di scarico 1.1/4"

Three holes basin mixer with 1.1/4" pop-up waste

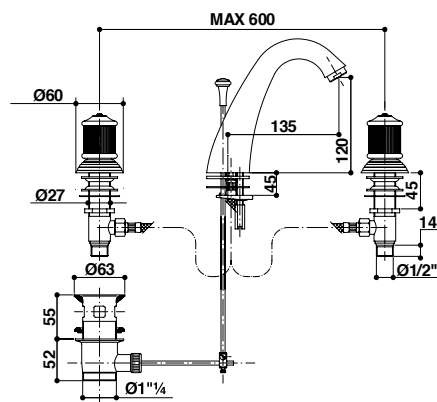

06503

Batteria bidet tre fori con bocca completa di scarico 1.1/4"

Three holes bidet mixer with spout and 1.1/4" pop-up waste

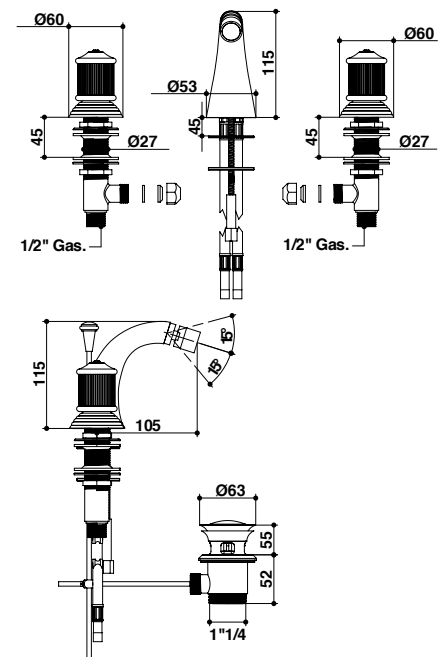

06502/D

Batteria bidet tre fori completa di scarico 1.1/4" e doccia

Three holes bidet mixer with shower and 1.1/4" pop-up waste

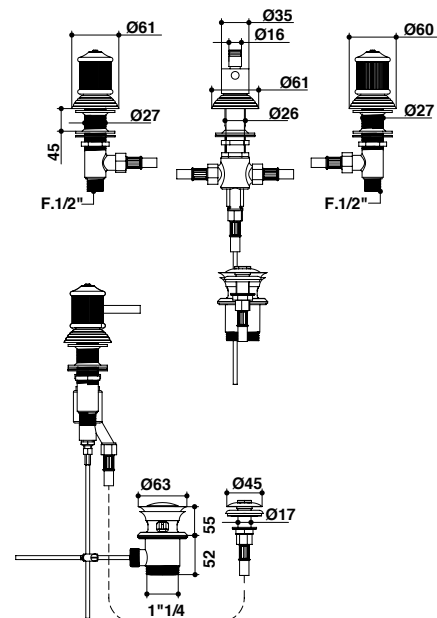

06521

Monoforo lavabo completo di scarico 1.1/4"

Basin monobloc with 1.1/4" pop-up waste

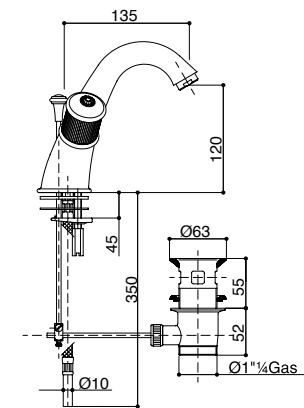



06522
 Monoforo bidet completo
 di scarico 1.1/4"
*Bidet monobloc with
 1.1/4" pop-up waste*

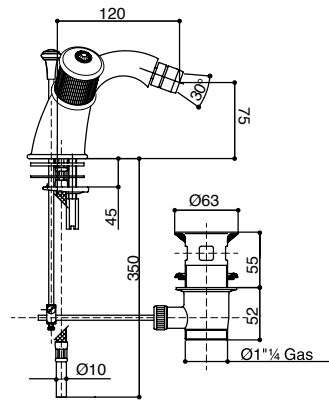

06526
 Gruppo vasca esterno
 con set doccia
*External bath and shower
 mixer with shower set*

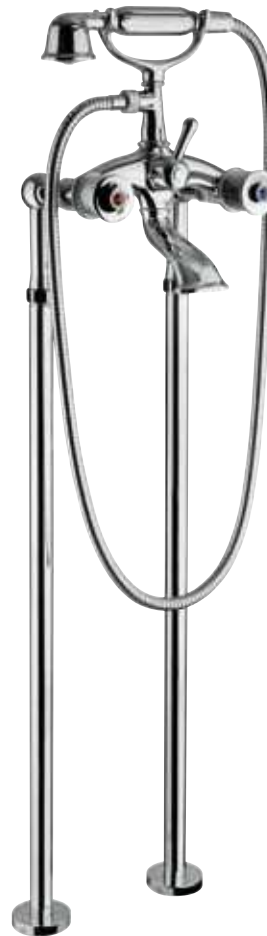
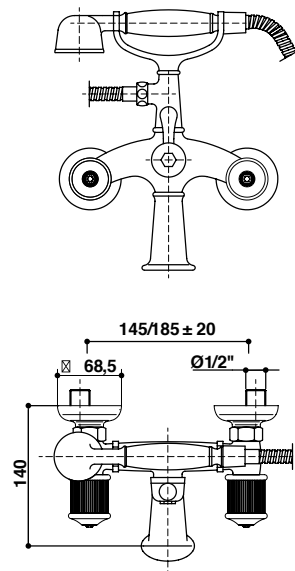

06528
 Gruppo vasca esterno su
 colonnette da terra con set doccia
*External bath and shower
 mixer to the floor with shower set*

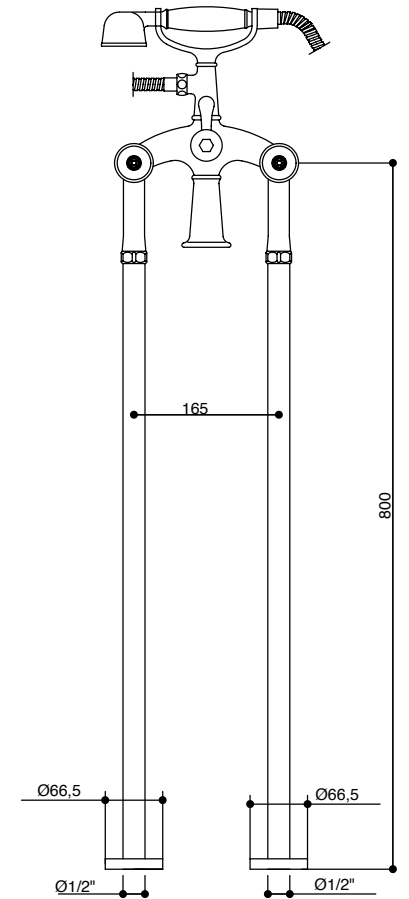

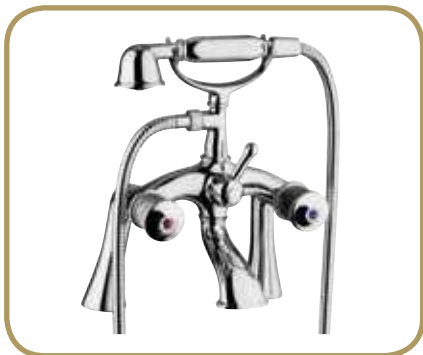

06527

Gruppo vasca con colonnette
bordo vasca e set doccia

*External bath and shower mixer
on pillar connection with shower set*

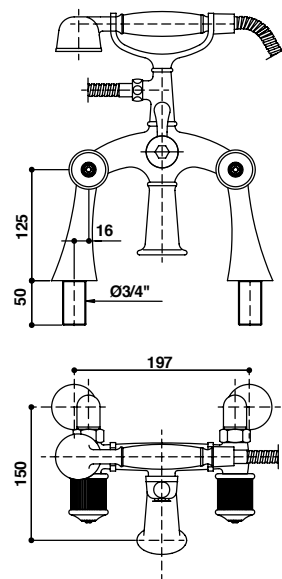

06537/D

Gruppo doccia esterno con tubo,
soffione e set doccia duplex

*External shower mixer with tube,
shower head and shower set duplex*

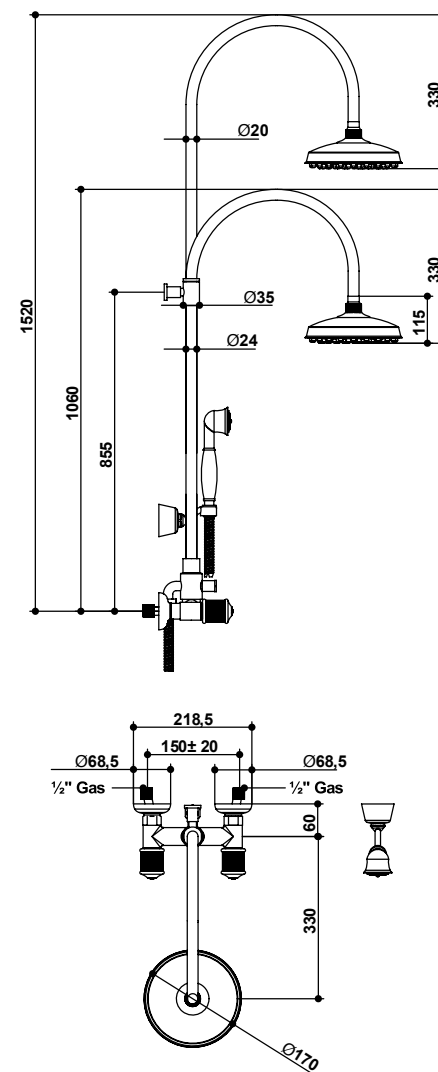



06530/D
 Gruppo vasca incasso
 con set doccia duplex
*Built-in bath and shower mixer
 with duplex shower set*

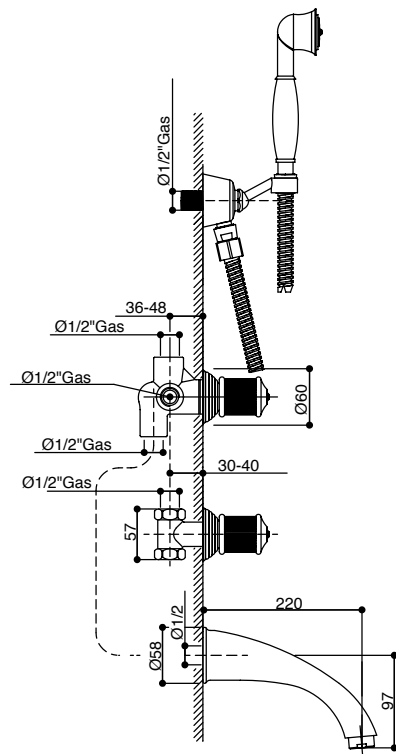

06531/D
 Gruppo bordo vasca cinque fori
*Five holes deck bath
 and shower mixer*

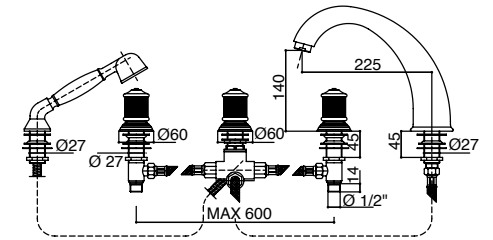

06500
 Rubinetto incasso 1/2"
1/2" built-in tap

06498
 Rubinetto incasso 3/4"
3/4" built-in tap

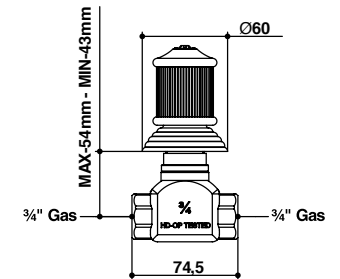
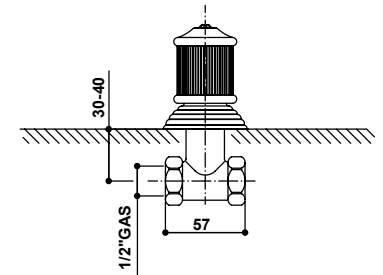



06525

Deviatore 4 vie
(2 entrate - 2 uscite)

*4 ways diverter
(2 in - 2 out)*

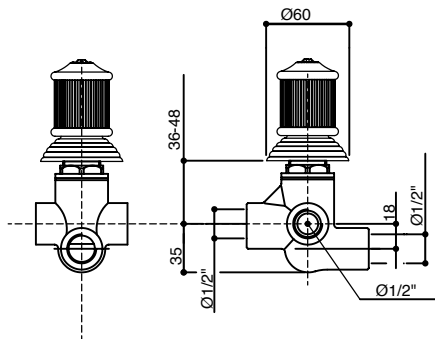

06544

Termostatico doccia incasso 1/2"

*1/2" built-in shower
thermostatic mixer*

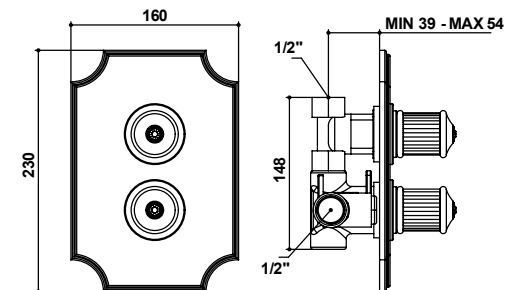

06525/5

Deviatore 5 vie
(2 entrate - 3 uscite)

*5 ways diverter
(2 in - 3 out)*

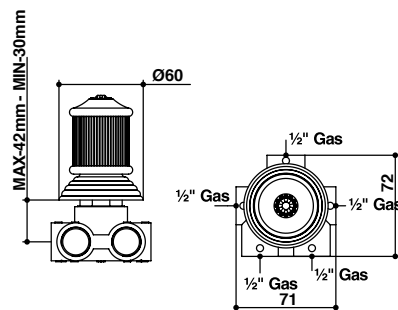

06523

Gruppo doccia esterno

External shower mixer

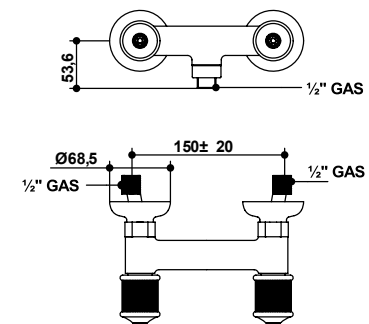

CRISTALLO





04501

Batteria lavabo tre fori completa di scarico 1.1/4"

Three holes basin mixer with 1.1/4" pop-up waste

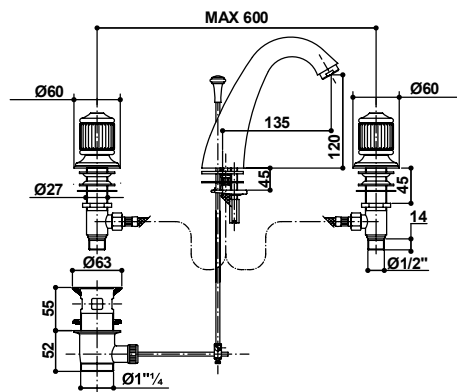

04503

Batteria bidet tre fori con bocca completa di scarico 1.1/4"

Three holes bidet mixer with spout and 1.1/4" pop-up waste

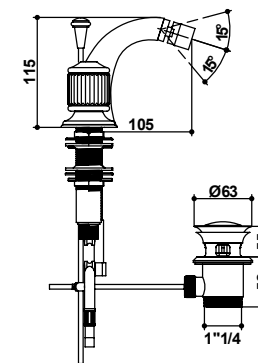
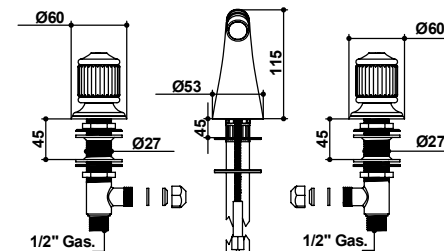

04502/D

Batteria bidet tre fori completa di scarico 1.1/4" e doccia

Three holes bidet mixer with shower and 1.1/4" pop-up waste

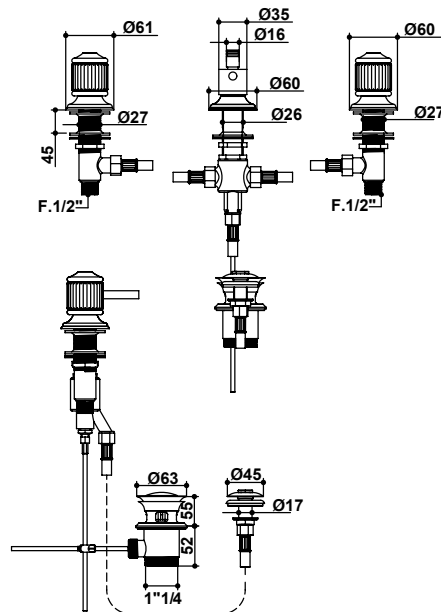

04521

Monoforo lavabo completo di scarico 1.1/4"

Basin monobloc with 1.1/4" pop-up waste

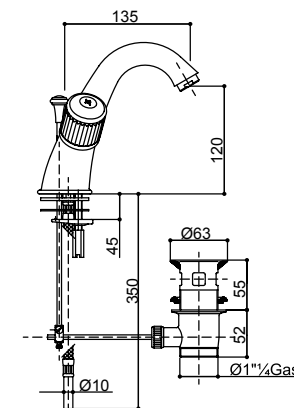



04522

Monoforo bidet completo
di scarico 1.1/4"

*Bidet monobloc with
1.1/4" pop-up waste*

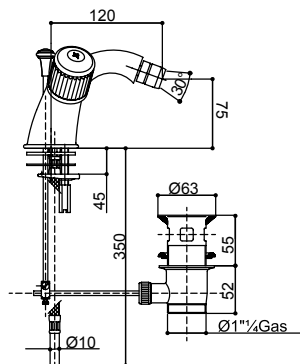

04526

Gruppo vasca esterno
con set doccia

*External bath and shower
mixer with shower set*

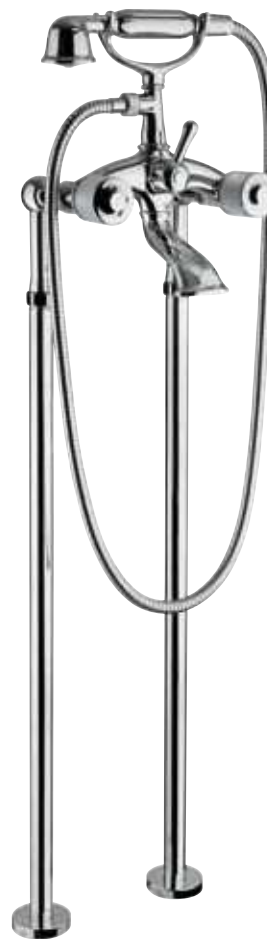
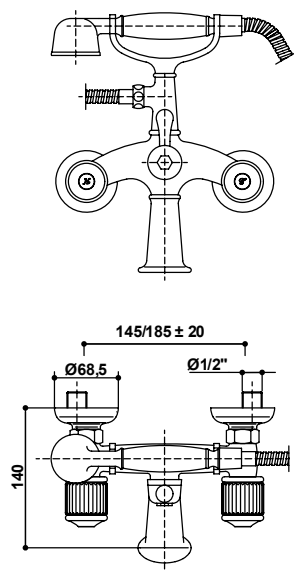

04528

Gruppo vasca esterno su colonnette
da terra con set doccia

*External bath and shower mixer
to the floor with shower set*

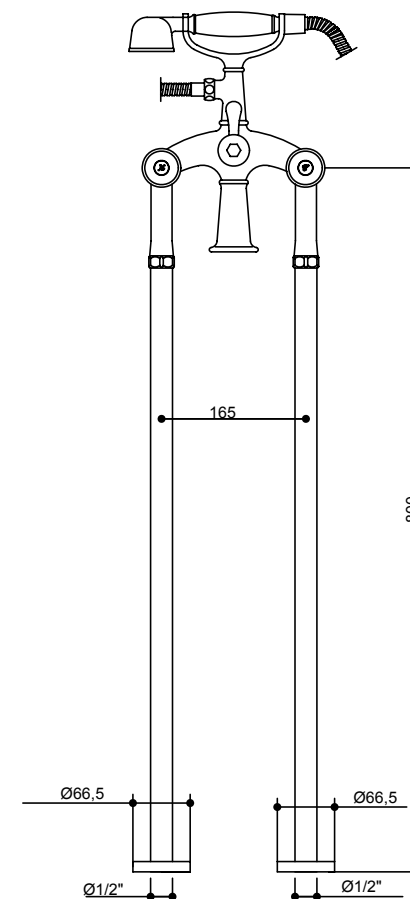

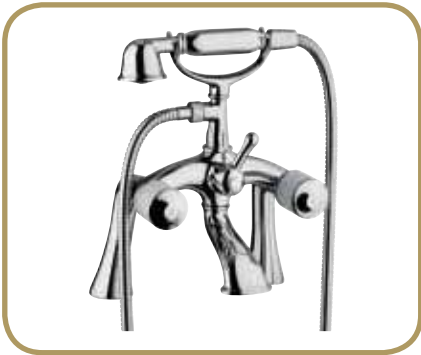

04527

Gruppo vasca con colonnette
bordo vasca e set doccia

*External bath and shower
mixer with shower set on deck legs*

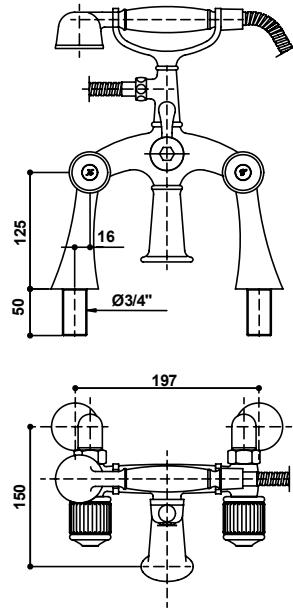

04537/D

Gruppo doccia esterno con tubo,
soffione e set doccia duplex

*External shower mixer with tube,
shower head and shower set duplex*

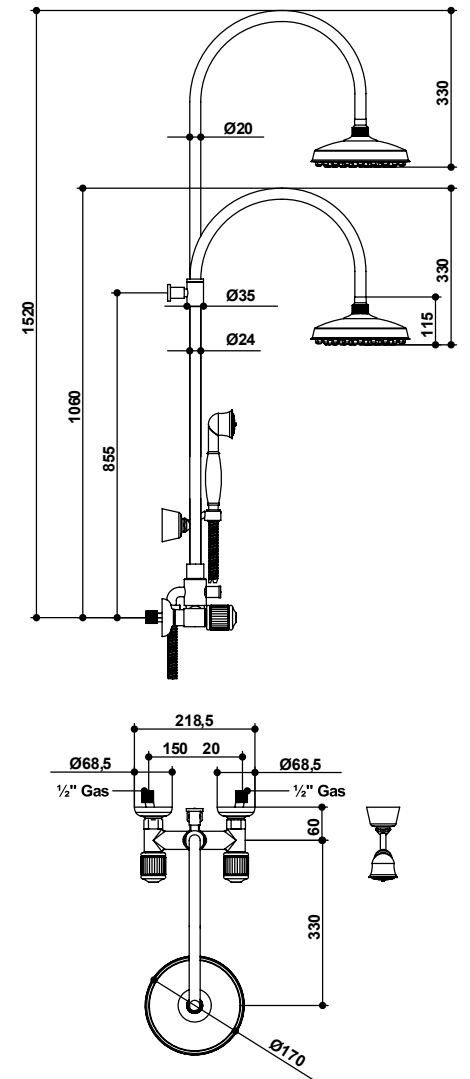



04530/D
 Gruppo vasca incasso
 con set doccia duplex
*Built-in bath and shower mixer
 with duplex shower set*

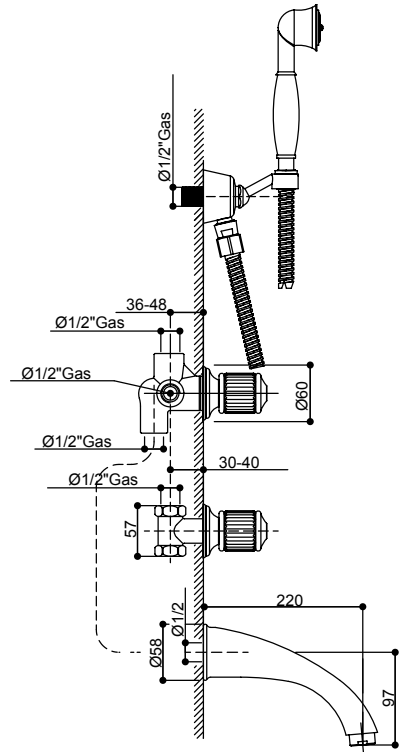

04531/D
 Gruppo bordo vasca cinque fori
*Five holes deck bath
 and shower mixer*

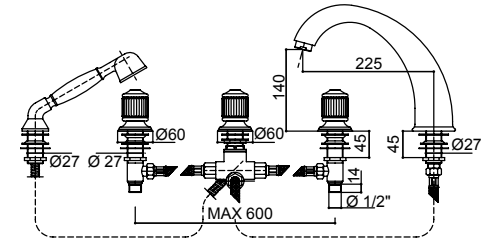

04500
 Rubinetto incasso 1/2"
1/2" built-in tap

04498
 Rubinetto incasso 3/4"
3/4" built-in tap

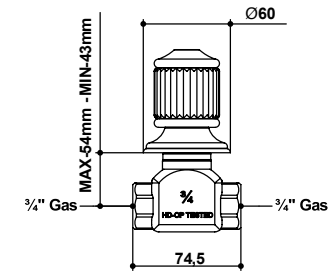
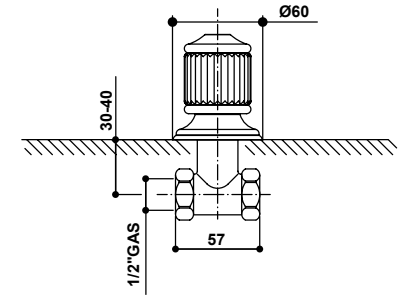



04525

Deviatore 4 vie
(2 entrate - 2 uscite)
*4 ways diverter
(2 in - 2 out)*

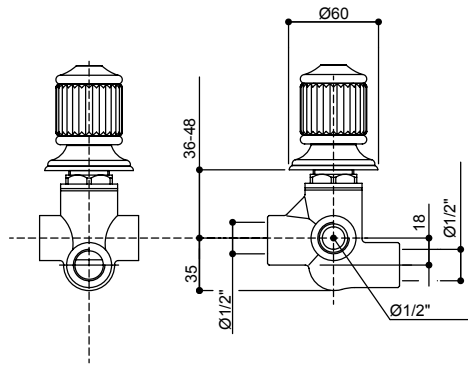

04544

Termostatico doccia incasso 1/2"
*1/2" built-in shower
hermostatic mixer*

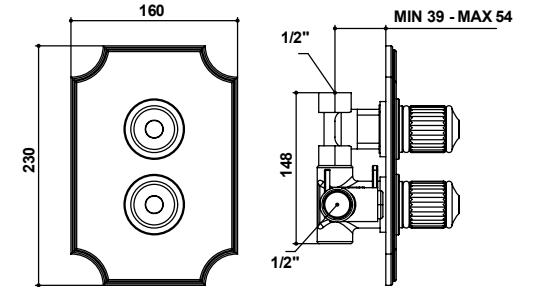

04525/5

Deviatore 5 vie
(2 entrate - 3 uscite)
*5 ways diverter
(2 in - 3 out)*

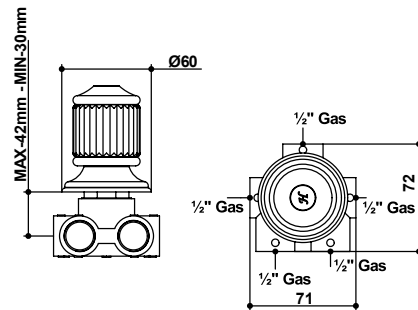

04523

Gruppo doccia esterno
External shower mixer

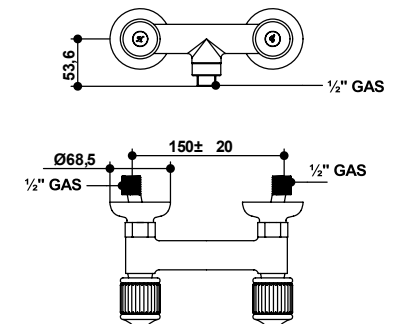

RADIANT

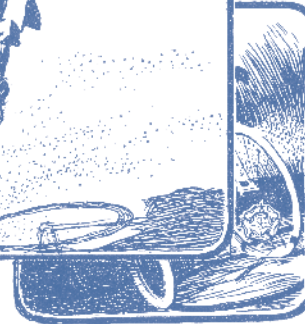
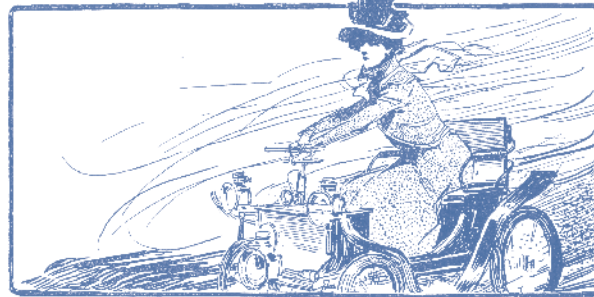



02501

Batteria lavabo tre fori completa di scarico 1.1/4"

Three holes basin mixer with 1.1/4" pop-up waste

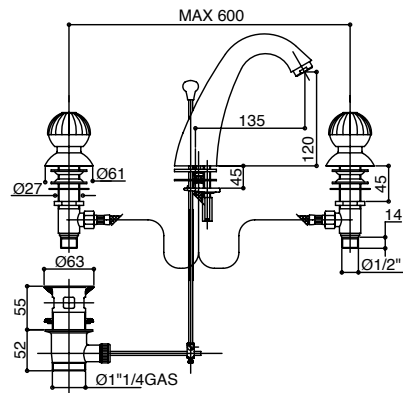

02503

Batteria bidet tre fori con bocca completa di scarico 1.1/4"

Three holes bidet mixer with spout and 1.1/4" pop-up waste

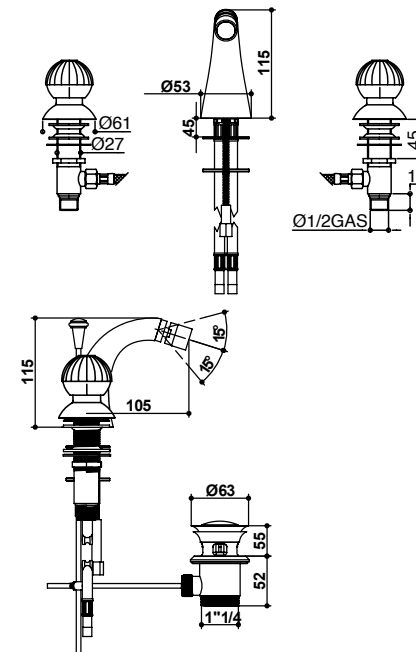

02502/D

Batteria bidet tre fori completa di scarico 1.1/4" e doccia

Three holes bidet mixer with shower and 1.1/4" pop-up waste

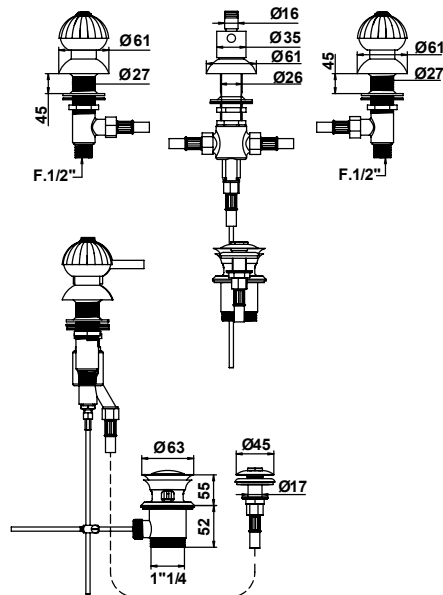

02521

Monoforo lavabo completo di scarico 1.1/4"

Basin monobloc with 1.1/4" pop-up waste

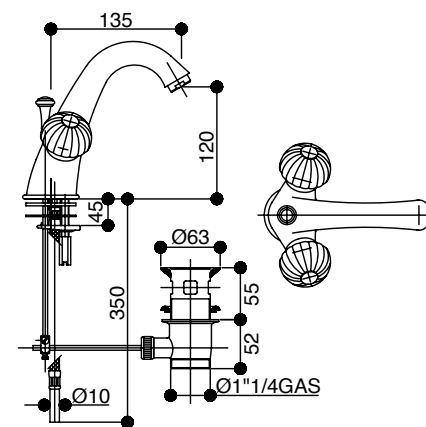



02522

Monoforo bidet completo
di scarico 1.1/4"

*Bidet monobloc with
1.1/4" pop-up waste*

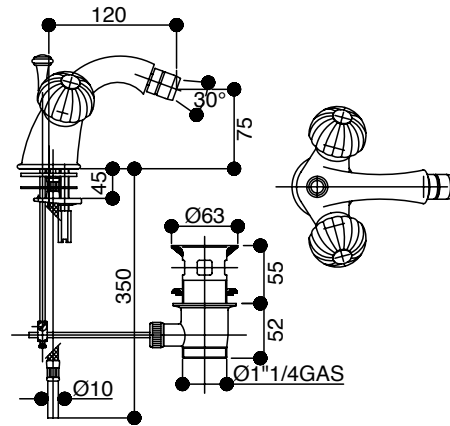

02526

Gruppo vasca esterno
con set doccia

*External bath and shower
mixer with shower set*

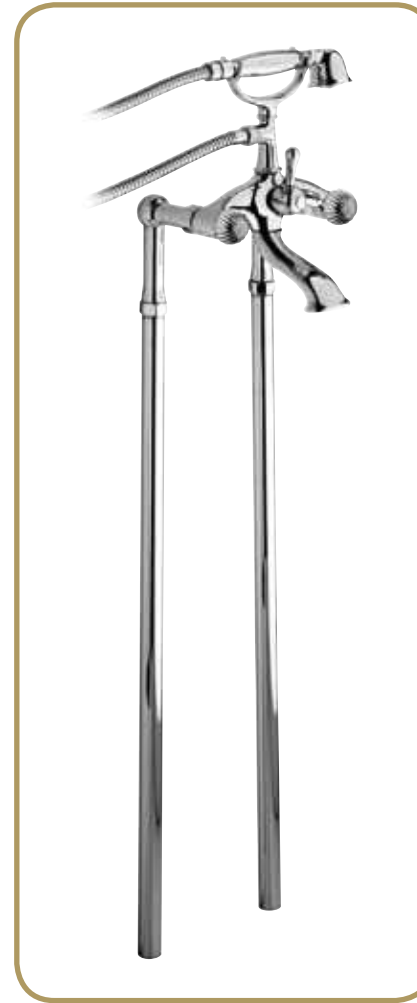
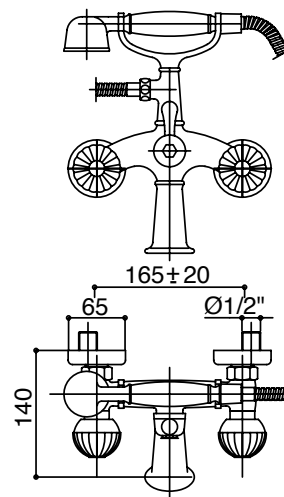

02528

Gruppo vasca esterno su
colonnette da terra con set doccia

*External bath and shower mixer
to the floor with shower set*

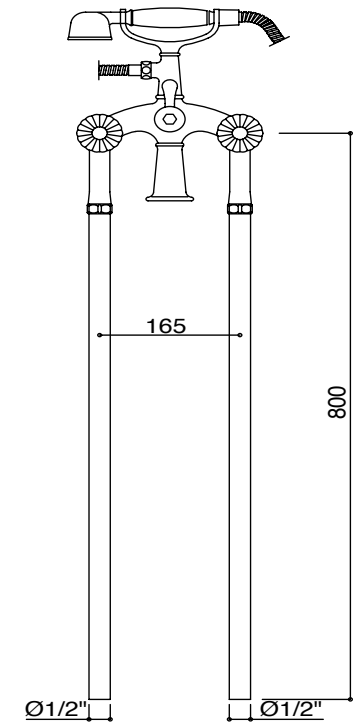



02527

Gruppo vasca con colonnette
bordo vasca e set doccia

*External bath and shower mixer
with shower set on deck legs*

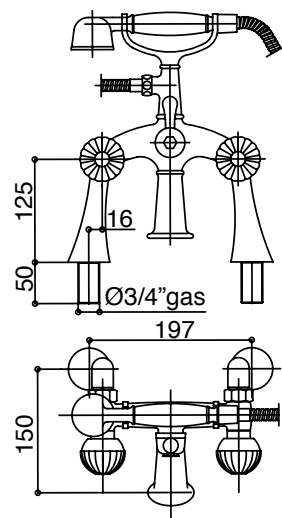

02537/D

Gruppo doccia esterno con tubo,
soffione e set doccia duplex

*External shower mixer with tube,
shower head and shower set duplex*

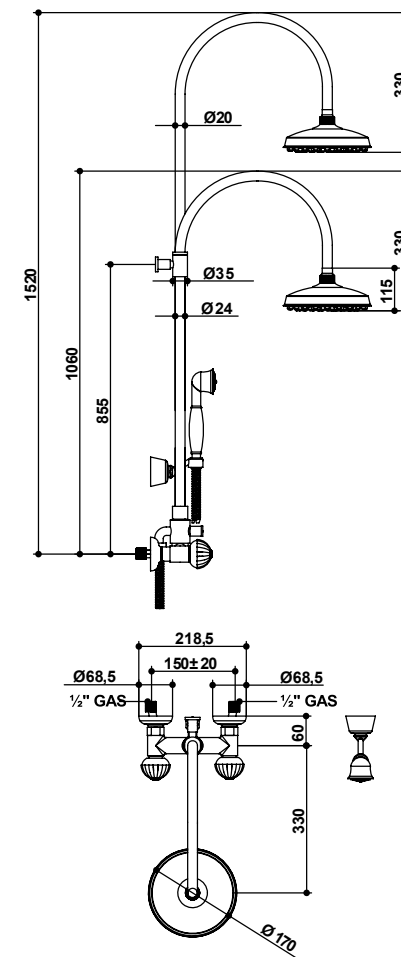



02530/D
 Gruppo vasca incasso
 con set doccia duplex
*Built-in bath and shower mixer
 with duplex shower set*

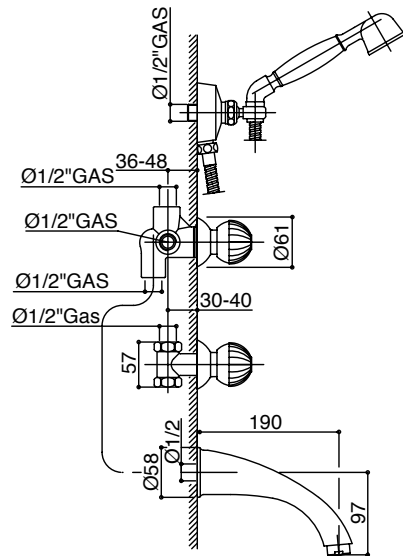

02531/D
 Gruppo bordo vasca cinque fori
Five holes deck bath and shower mixer

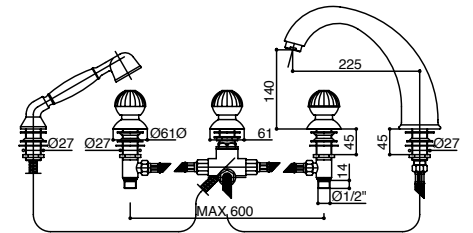

02500
 Rubinetto incasso 1/2"
1/2" built-in tap

02498
 Rubinetto incasso 3/4"
3/4" built-in tap

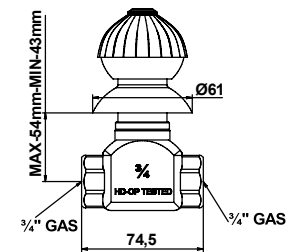
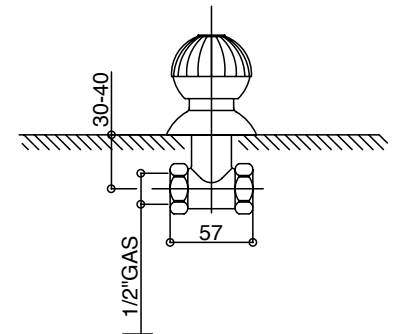



02525
 Deviatore 4 vie
 (2 entrate - 2 uscite)
4 ways diverter
 (2 in - 2 out)

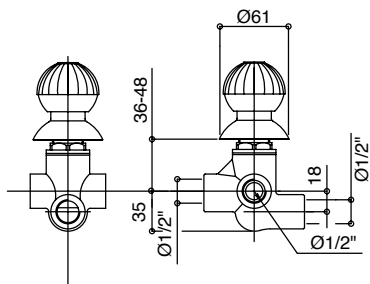

02544
 Termostatico doccia incasso 1/2"
1/2" built-in shower
thermostatic mixer

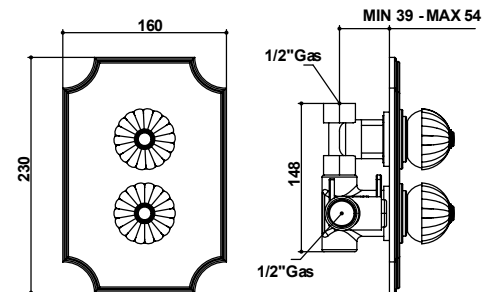

02525/5
 Deviatore 5 vie
 (2 entrate - 3 uscite)
5 ways diverter
 (2 in - 3 out)

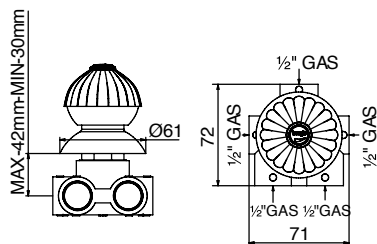

02523
 Gruppo doccia esterno
External shower mixer

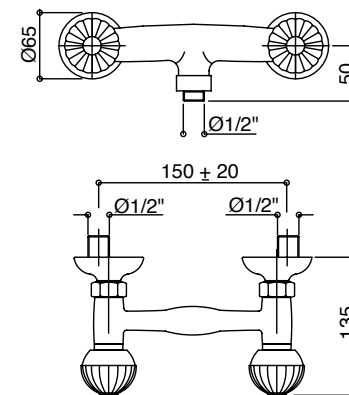

RIVOLI





05501

Batteria lavabo tre fori completa di scarico 1.1/4"

Three holes basin mixer with 1.1/4" pop-up waste

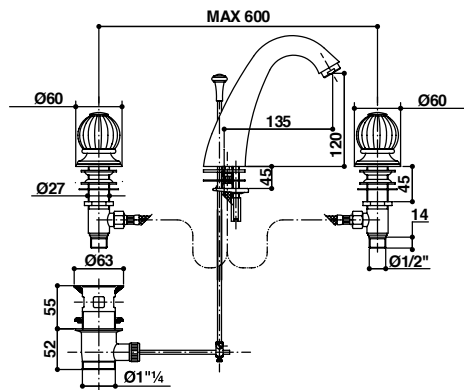

05503

Batteria bidet tre fori con bocca completa di scarico 1.1/4"

Three holes bidet mixer with spout and 1.1/4" pop-up waste

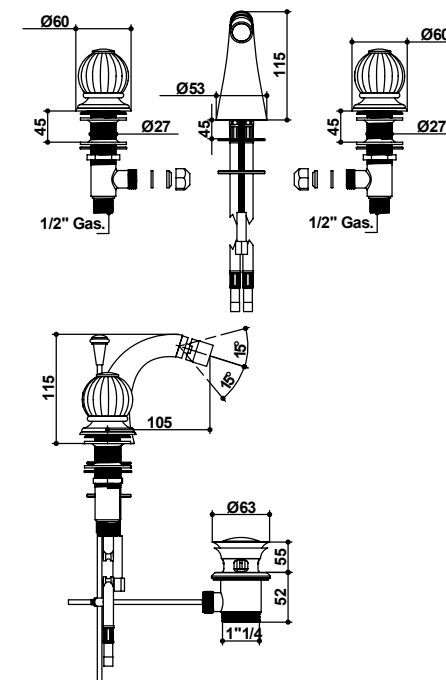

05502/D

Batteria bidet tre fori completa di scarico 1.1/4" e doccia

Three holes bidet mixer with shower and 1.1/4" pop-up waste

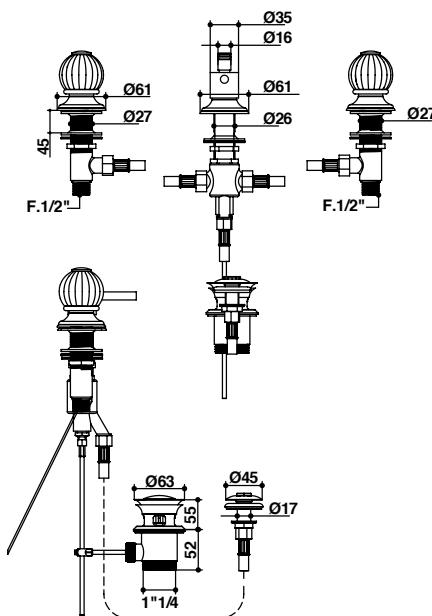

05521

Monoforo lavabo completo di scarico 1.1/4"

Basin monobloc with 1.1/4" pop-up waste

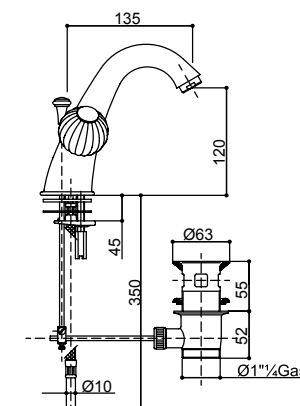



05522

Monoforo bidet completo
di scarico 1.1/4"

*Bidet monobloc with
1.1/4" pop-up waste*

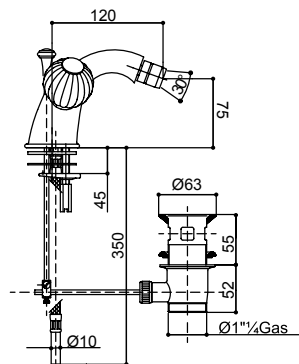

05526

Gruppo vasca esterno
con set doccia

*External bath and shower
mixer with shower set*

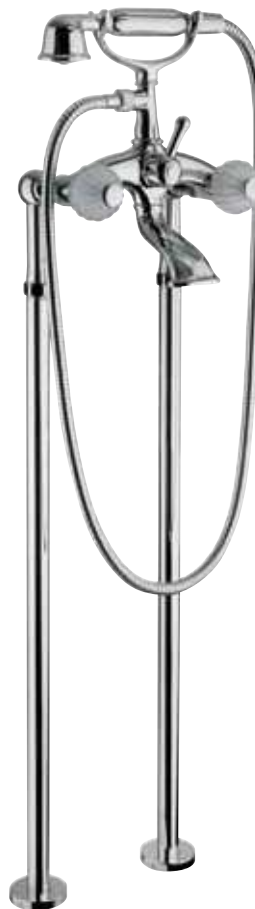
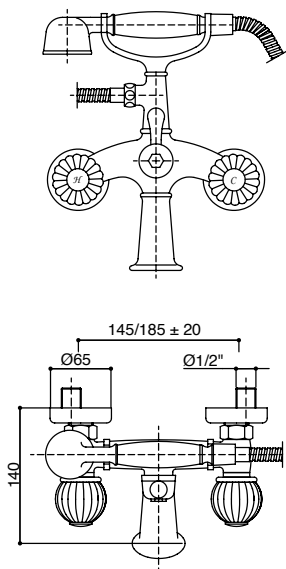

05528

Gruppo vasca esterno su colonnette
da terra con set doccia

*External bath and shower mixer
to the floor with shower set*

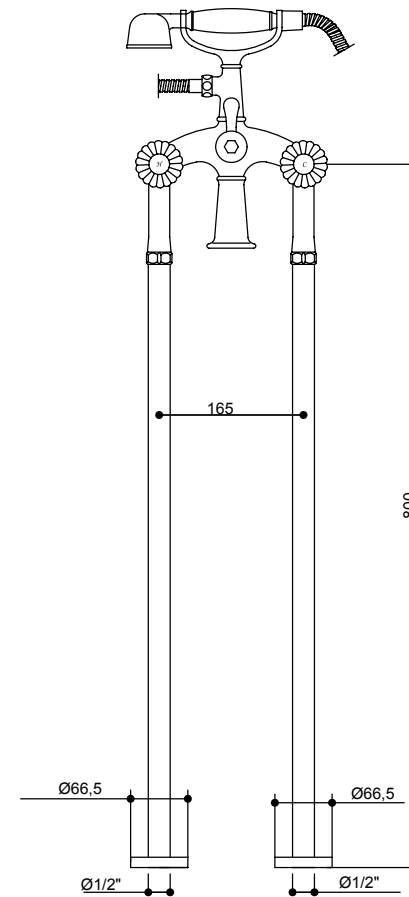



05527

Gruppo vasca con colonnette
bordo vasca e set doccia

*External bath and shower
mixer with shower set on deck legs*

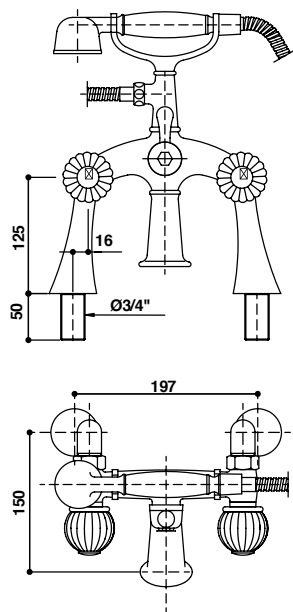

05537/D

Gruppo doccia esterno con tubo,
soffione e set doccia duplex

*External shower mixer with tube,
shower head and shower set duplex*

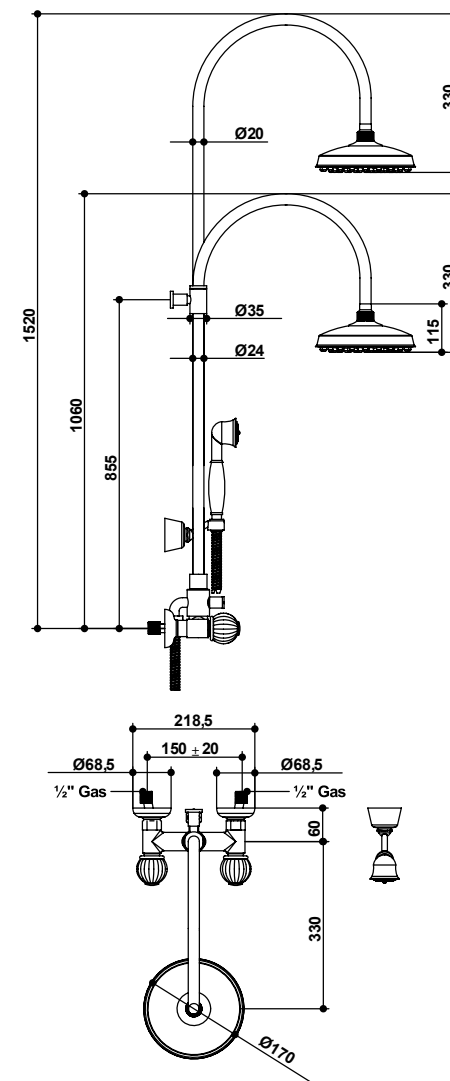



05530/D
 Gruppo vasca incasso
 con set doccia duplex
*Built-in bath and shower mixer
 with duplex shower set*

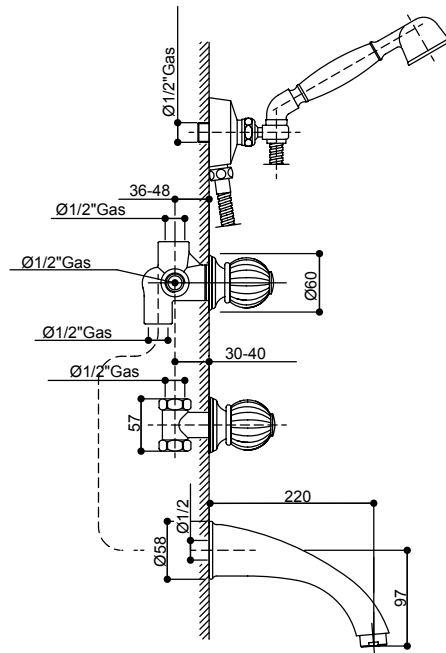

05531/D
 Gruppo bordo vasca cinque fori
Five holes deck bath and shower mixer

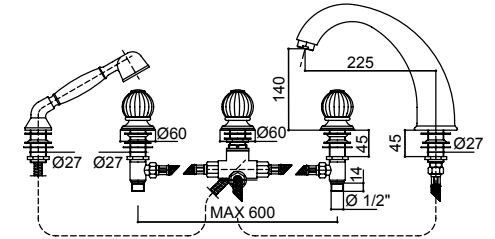

05500
 Rubinetto incasso 1/2"
1/2" built-in tap

05498
 Rubinetto incasso 3/4"
3/4" built-in tap

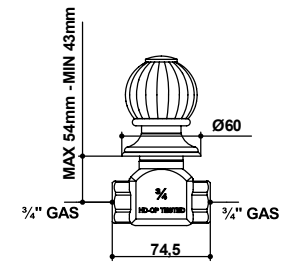
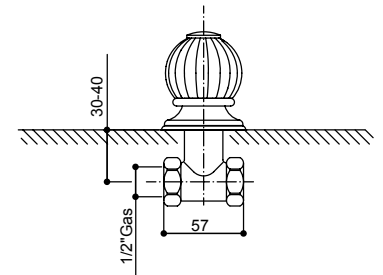



05525

Deviatore 4 vie
(2 entrate 2 uscite)
*4 ways diverter
(2 in - 2 out)*

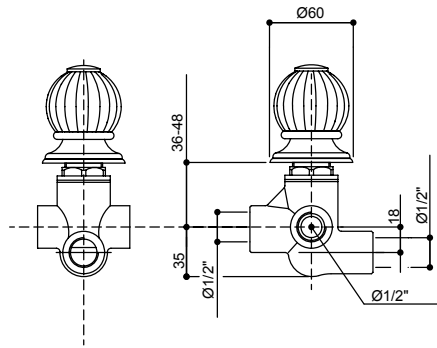

05544

Termostatico doccia incasso 1/2"
*1/2" built-in shower
thermostatic mixer*

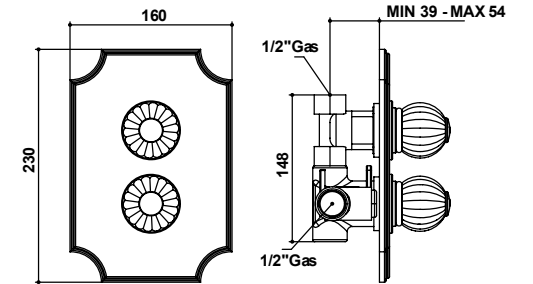

05525/5

Deviatore 5 vie
(2 entrate - 3 uscite)
*5 ways diverter
(2 in - 3 out)*

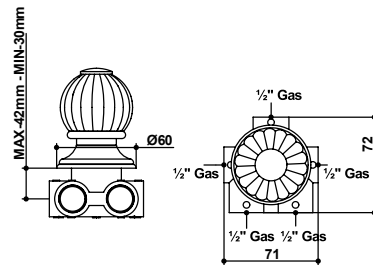

05523

Gruppo doccia esterno
External shower mixer

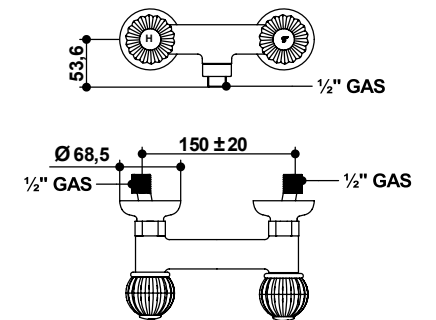

FLEUR
BLANC



FLEUR
NOIR





11501 FLEUR BLANC
12501 FLEUR NOIR
Batteria lavabo tre fori completa di scarico 1.1/4"
Three holes basin mixer with 1.1/4" pop-up waste

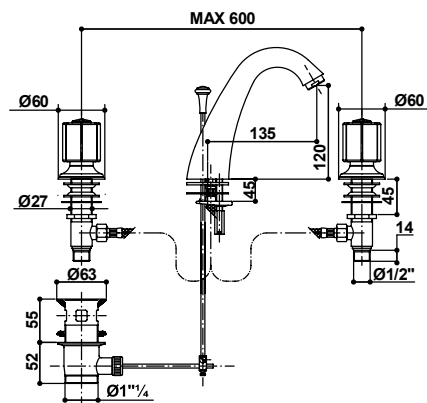

11503 FLEUR BLANC
12503 FLEUR NOIR
Batteria bidet tre fori con bocca completa di scarico 1.1/4"
Three holes bidet mixer with spout and 1.1/4" pop-up waste

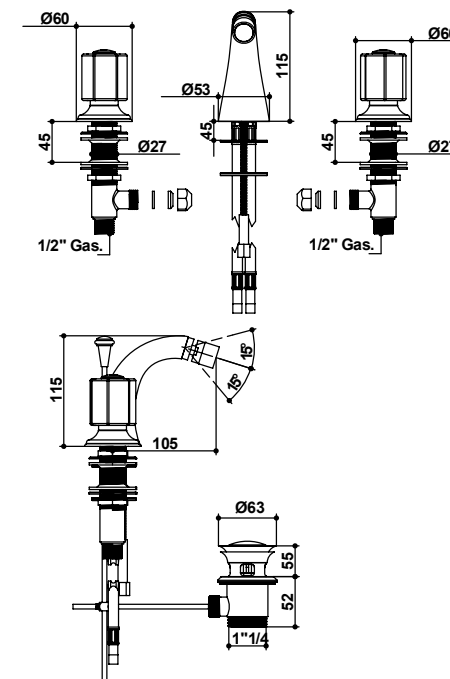

11502/D FLEUR BLANC
12502/D FLEUR NOIR
Batteria bidet tre fori completa di scarico 1.1/4" e doccia
Three holes bidet mixer with shower and 1.1/4" pop-up waste

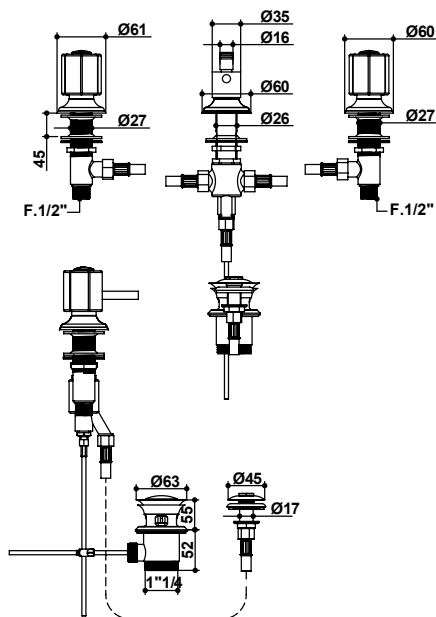

11521 FLEUR BLANC
12521 FLEUR NOIR
Monoforo lavabo completo di scarico 1.1/4"
Basin monobloc with 1.1/4" pop-up waste

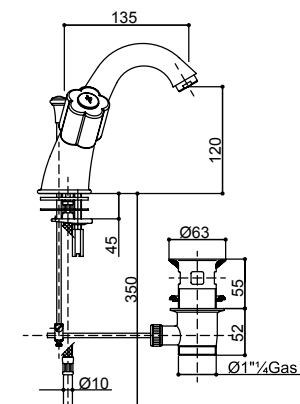



11522 FLEUR BLANC
12522 FLEUR NOIR
Monoforo bidet completo
di scarico 1.1/4"
*Bidet monobloc with
1.1/4" pop-up waste*

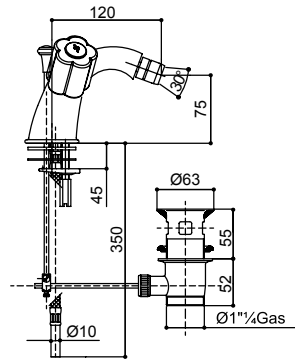

11526 FLEUR BLANC
12526 FLEUR NOIR
Gruppo vasca esterno
con set doccia
*External bath and shower
mixer with shower set*

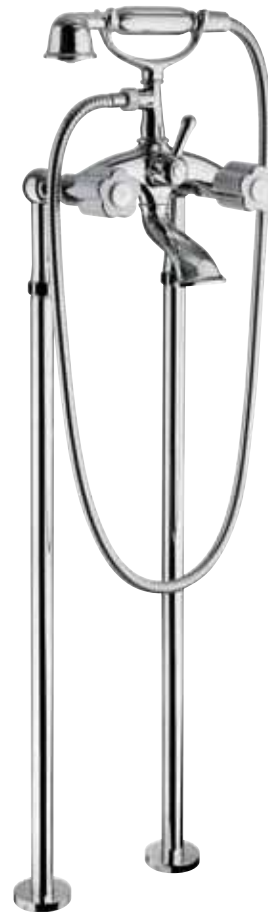
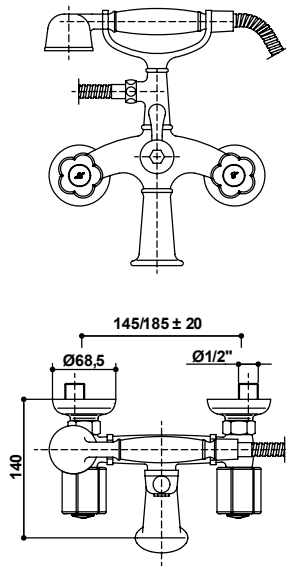

11528 FLEUR BLANC
12528 FLEUR NOIR
Gruppo vasca esterno su
colonnate da terra con set doccia
*External bath and shower mixer
to the floor with shower set*

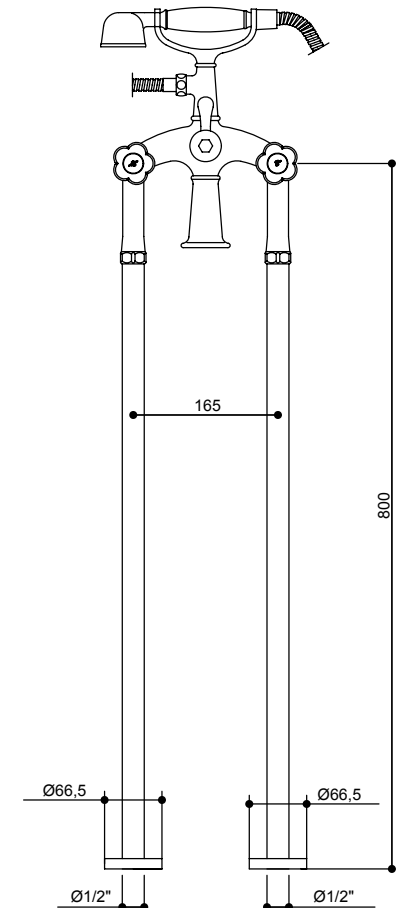



11527 FLEUR BLANC
12527 FLEUR NOIR
Gruppo vasca con colonnette
bordo vasca e set doccia
*External bath and shower
mixer with shower set on deck legs*

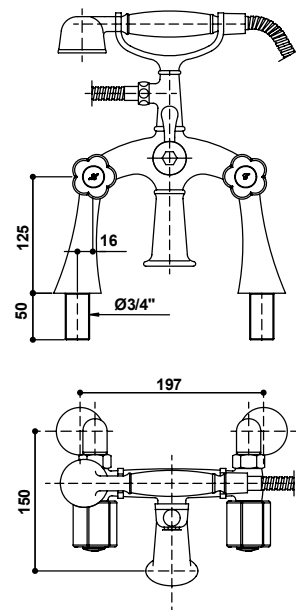

11537/D FLEUR BLANC
12537/D FLEUR NOIR
Gruppo doccia esterno con tubo,
soffione e set doccia duplex
*External shower mixer with tube,
shower head and shower set duplex*

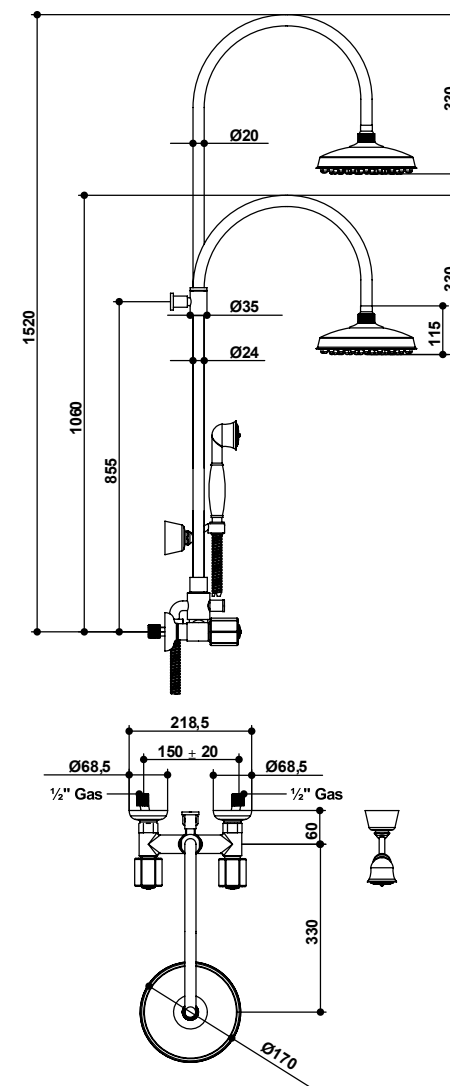



11530/D FLEUR BLANC
12530/D FLEUR NOIR

Gruppo vasca incasso
 con set doccia duplex
*Built-in bath and shower mixer
 with duplex shower set*

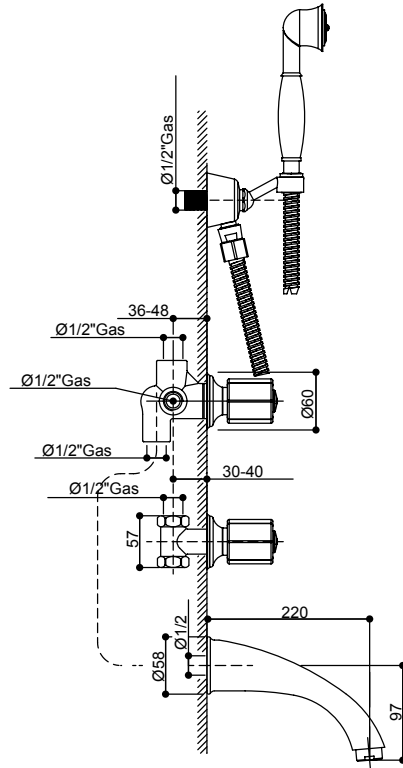

11531/D FLEUR BLANC
12531/D FLEUR NOIR
 Gruppo bordo vasca cinque fori
Five holes deck bath and shower mixer

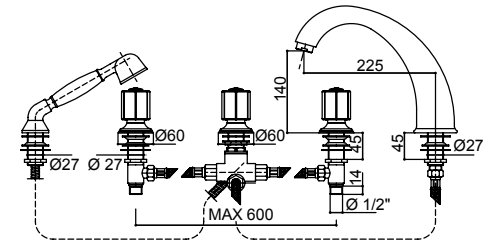

11500 FLEUR BLANC
12500 FLEUR NOIR
 Rubinetto incasso 1/2"
1/2" built-in tap

11498 FLEUR BLANC
12498 FLEUR NOIR
 Rubinetto incasso 3/4"
3/4" built-in tap

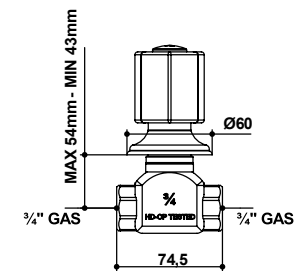
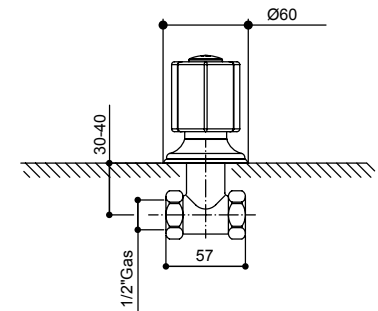



11525 FLEUR BLANC
12525 FLEUR NOIR
Deviatore 4 vie
(2 entrate - 2 uscite)
*4 ways diverter
(2 in - 2 out)*

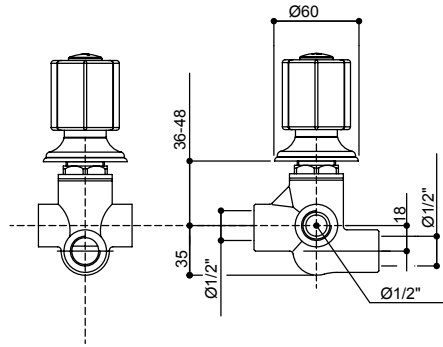

11544 FLEUR BLANC
12544 FLEUR NOIR
Termostatico doccia incasso 1/2"
*1/2" built-in shower
thermostatic mixer*

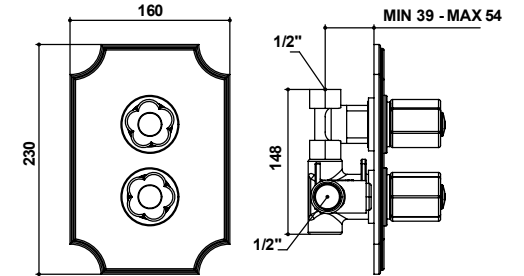

11525/5 FLEUR BLANC
12525/5 FLEUR NOIR
Deviatore 5 vie
(2 entrate - 3 uscite)
*5 ways diverter
(2 in - 3 out)*

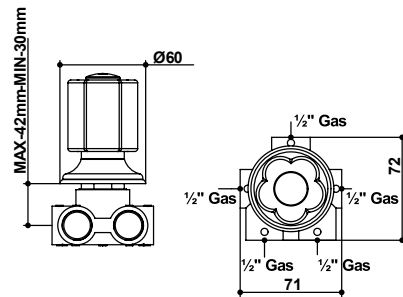

11523 FLEUR BLANC
12523 FLEUR NOIR
Gruppo doccia esterno
External shower mixer

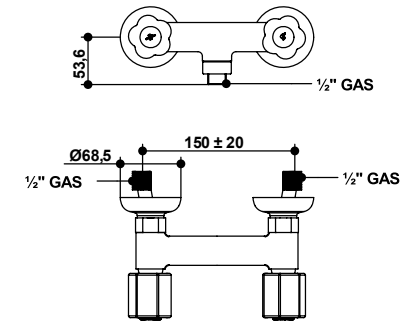

CAPRI

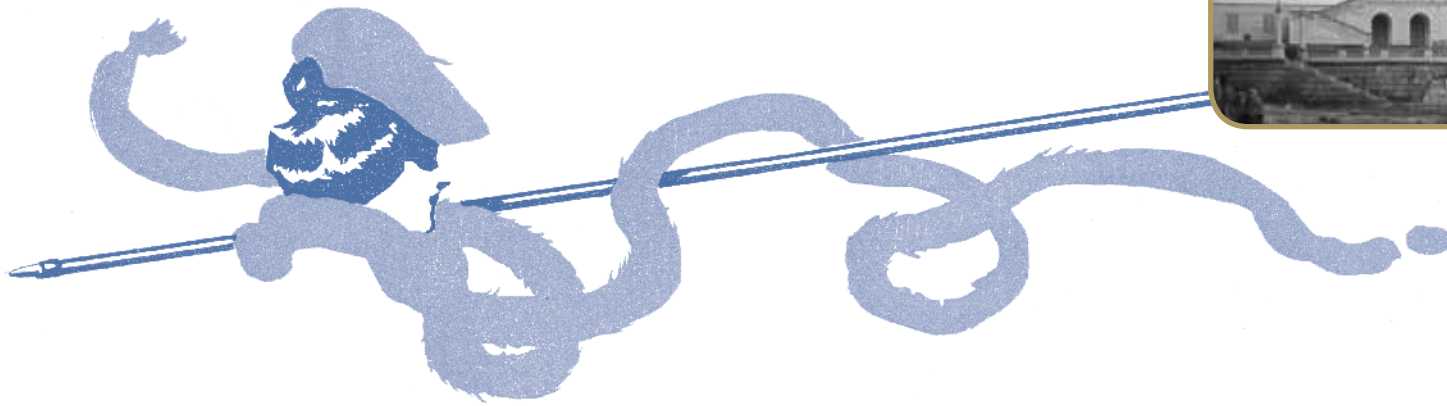



17501

Batteria lavabo tre fori completa di scarico 1.1/4"

Three holes basin mixer with 1.1/4" pop-up waste

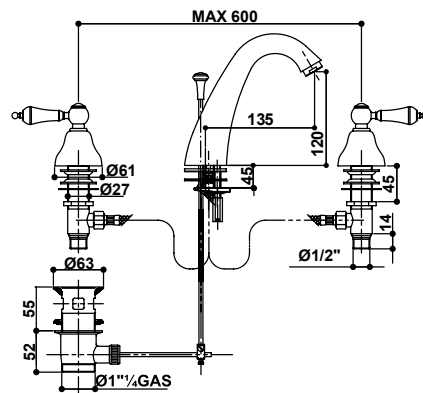

17501/B

Batteria lavabo tre fori completa di scarico 1.1/4" bocca bassa

Three holes basin mixer with short spout and 1.1/4" pop-up waste

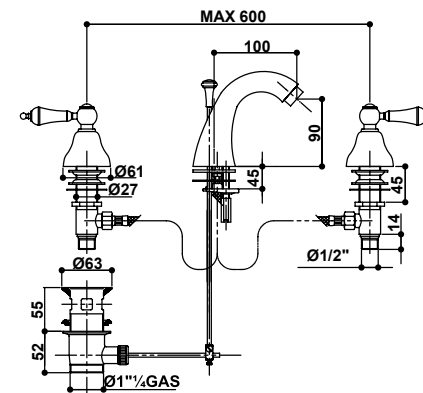

17503

Batteria bidet tre fori con bocca completa di scarico 1.1/4"

Three holes bidet mixer with spout and 1.1/4" pop-up waste

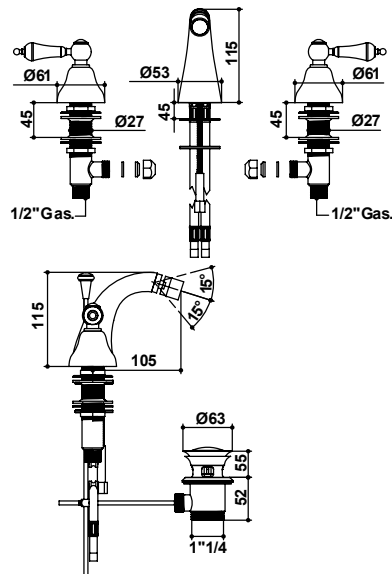

17502/D

Batteria bidet tre fori completa di scarico 1.1/4" e doccetta

Three holes bidet mixer with shower and 1.1/4" pop-up waste

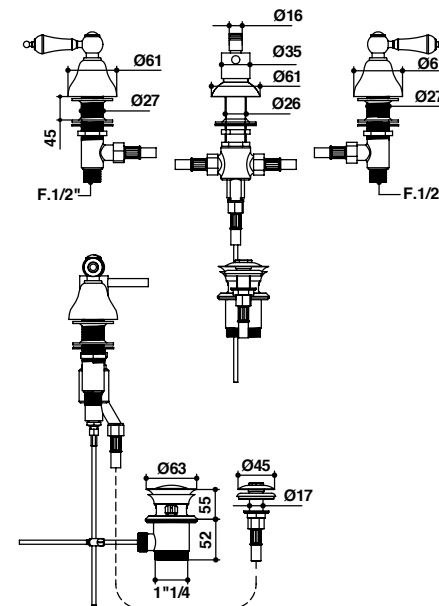



17521

Monoforo lavabo completo
di scarico 1.1/4"

*Basin monobloc with
1.1/4" pop-up waste*

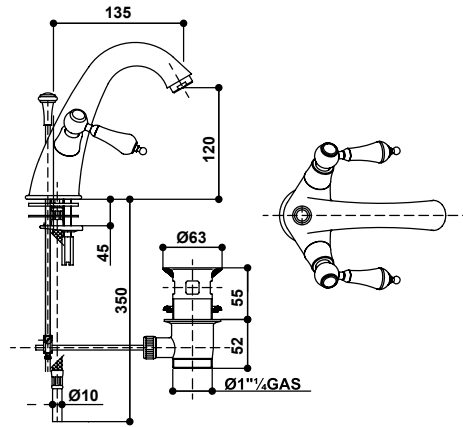

17522

Monoforo bidet completo
di scarico 1.1/4"

*Bidet monobloc with
1.1/4" pop-up waste*

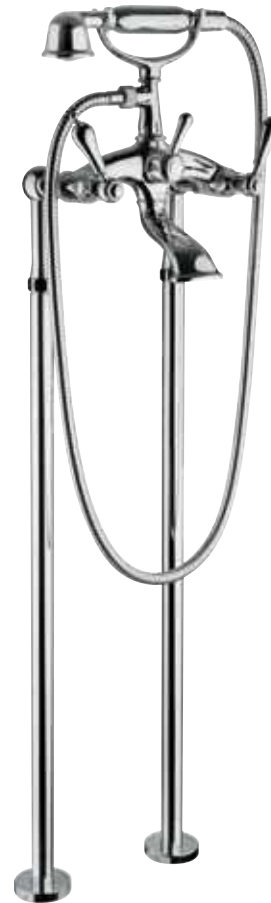
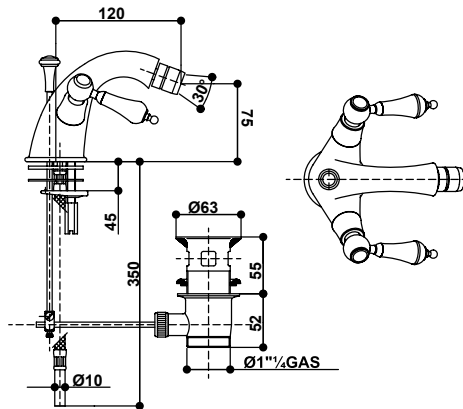

17528

Gruppo vasca esterno su colonnette
da terra con set doccia

*External bath and shower mixer
to the floor with shower set*

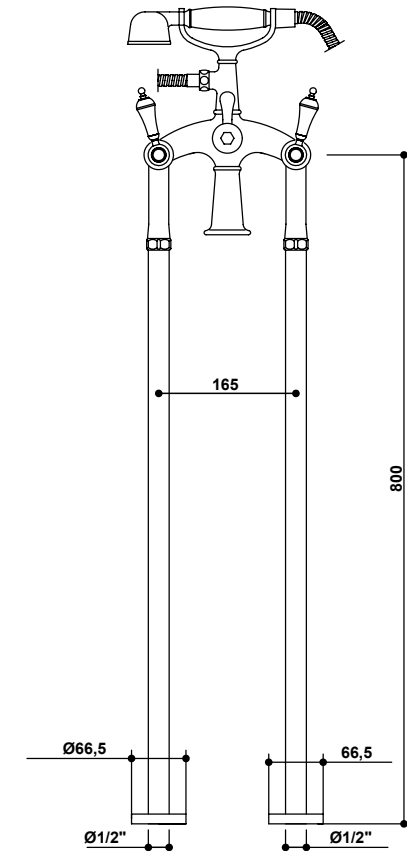



17527
 Gruppo vasca con colonnette
 bordo vasca e set doccia
*External bath and shower
 mixer with shower set on deck legs*

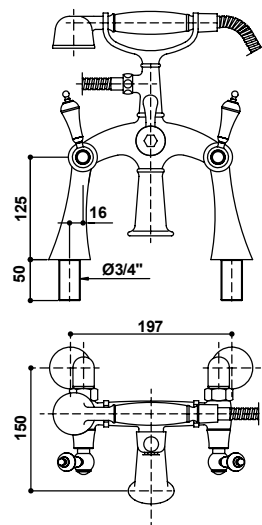

17526
 Gruppo vasca esterno
 con set doccia
*External bath and shower
 mixer with shower set*

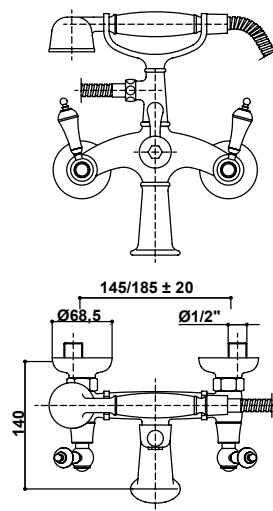

17537/D
 Gruppo doccia esterno con tubo,
 soffione e set doccia duplex
*External shower mixer with tube,
 shower head and shower set duplex*

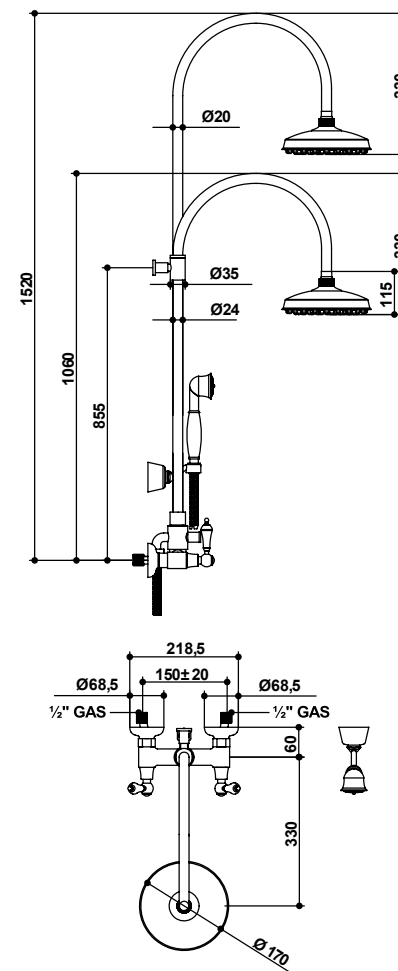



17530/D
 Gruppo vasca incasso
 con set doccia duplex
*Built-in bath and shower
 mixer with duplex shower set*

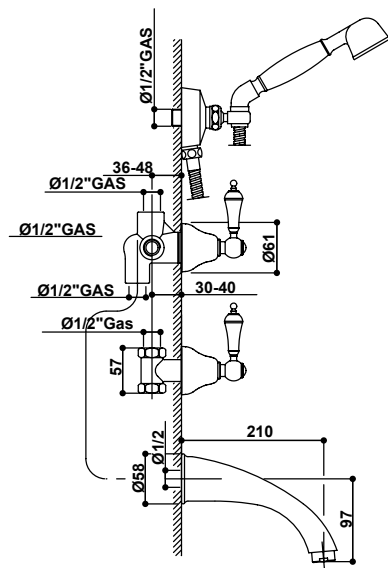

17531/D
 Gruppo bordo vasca cinque fori
Five holes deck bath and shower mixer

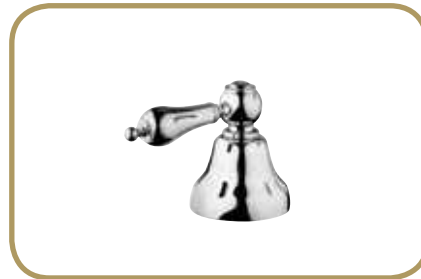
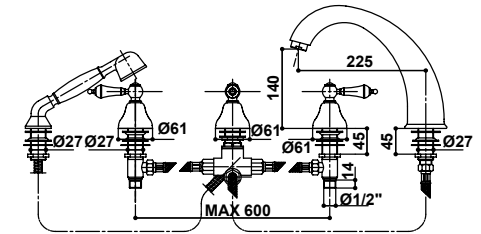

17500
 Rubinetto incasso 1/2"
1/2" built-in tap

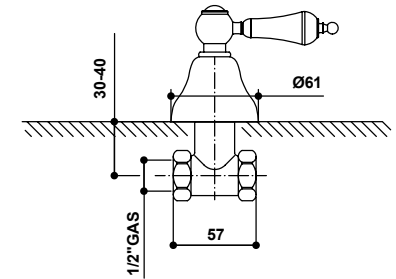

17498
 Rubinetto incasso 3/4"
3/4" built-in tap

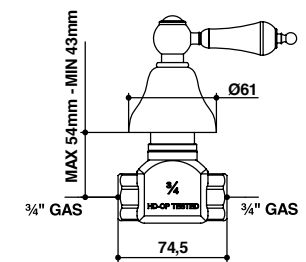



17525
 Deviatore 4 vie
 (2 entrate - 2 uscite)
4 ways diverter
 (2 in - 2 out)

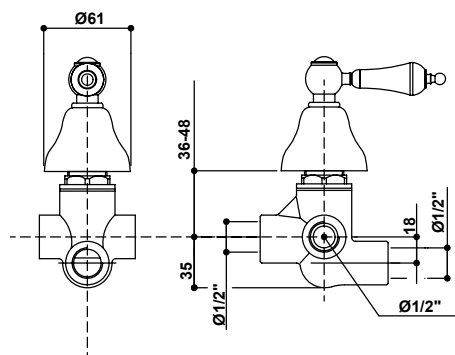

17544
 Termostatico doccia incasso 1/2"
1/2" built-in shower
thermostatic mixer

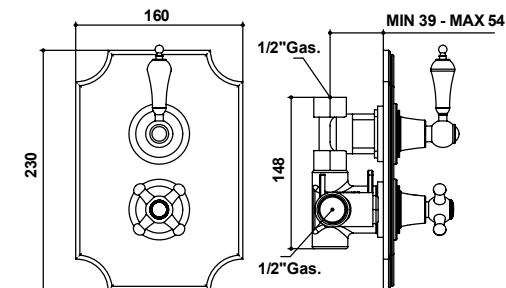

17525/5
 Deviatore 5 vie
 (2 entrate - 3 uscite)
5 ways diverter
 (2 in - 3 out)

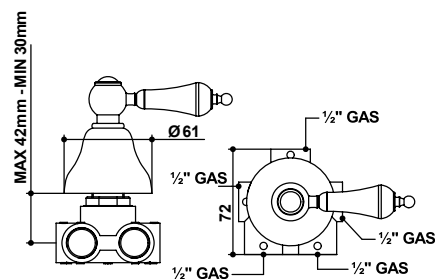

17523
 Gruppo doccia esterno
External shower mixer

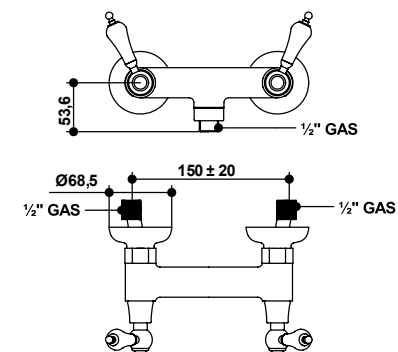

AXEL





15501

Batteria lavabo tre fori completa di scarico 1.1/4"

Three holes basin mixer with 1.1/4" pop-up waste

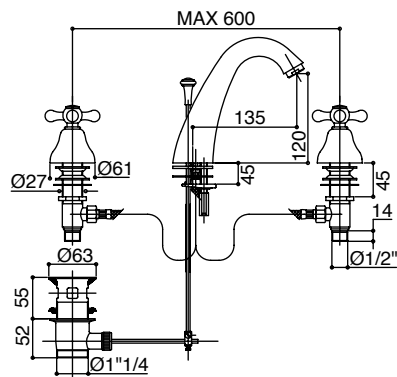

15503

Batteria bidet tre fori con bocca completa di scarico 1.1/4"

Three holes bidet mixer with spout and 1.1/4" pop-up waste

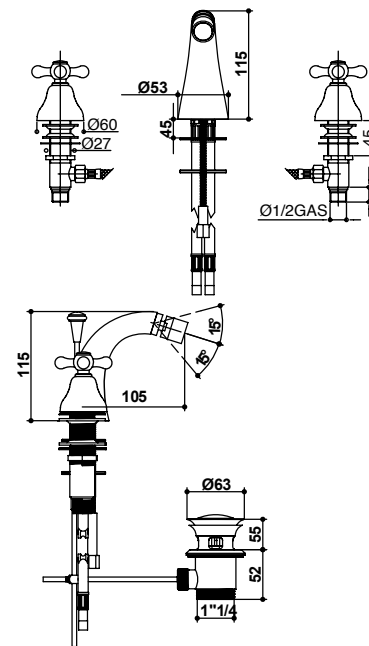

15502/D

Batteria bidet tre fori completa di scarico 1.1/4" e doccia

Three holes bidet mixer with shower and 1.1/4" pop-up waste

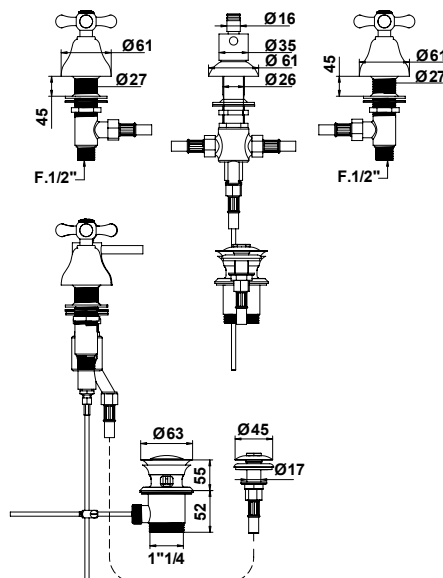

15521

Monoforo lavabo completo di scarico 1.1/4"

Basin monobloc with 1.1/4" pop-up waste

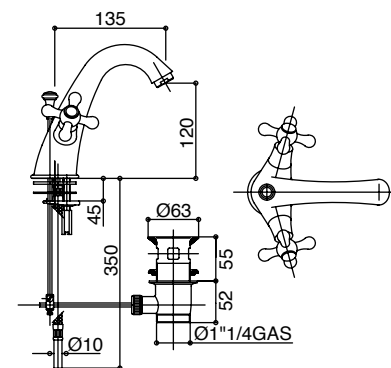



15522
 Monoforo bidet completo
 di scarico 1.1/4"
*Bidet monobloc with
 1.1/4" pop-up waste*

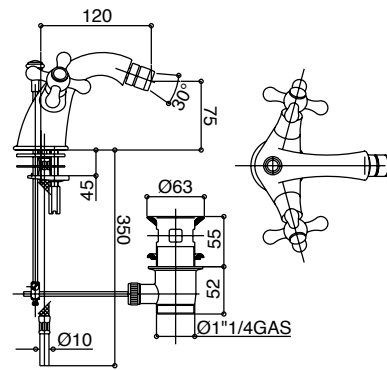

15526
 Gruppo vasca esterno
 con set doccia
*External bath and shower
 mixer with shower set*

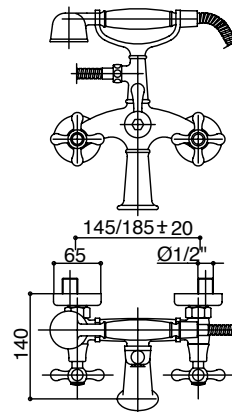

15528
 Gruppo vasca esterno su colonnette
 da terra con set doccia
*External bath and shower
 mixer to the floor with shower set*

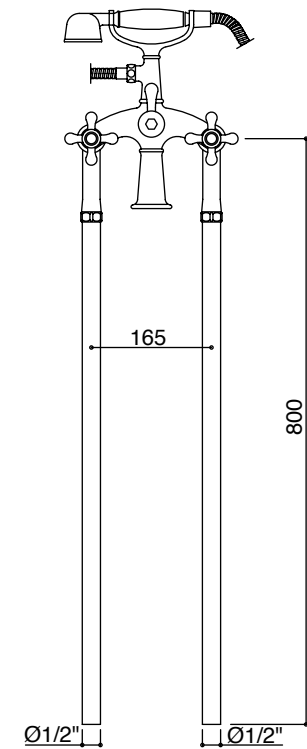



15527

Gruppo vasca con colonnette
bordo vasca e set doccia

*External bath and shower
mixer with shower set on deck legs*

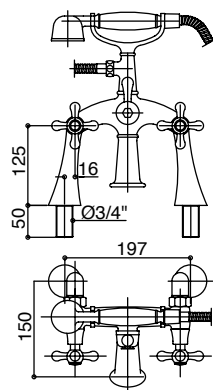

15537/D

Gruppo doccia esterno con tubo,
soffione e set doccia duplex

*External shower mixer with tube,
shower head and shower set duplex*

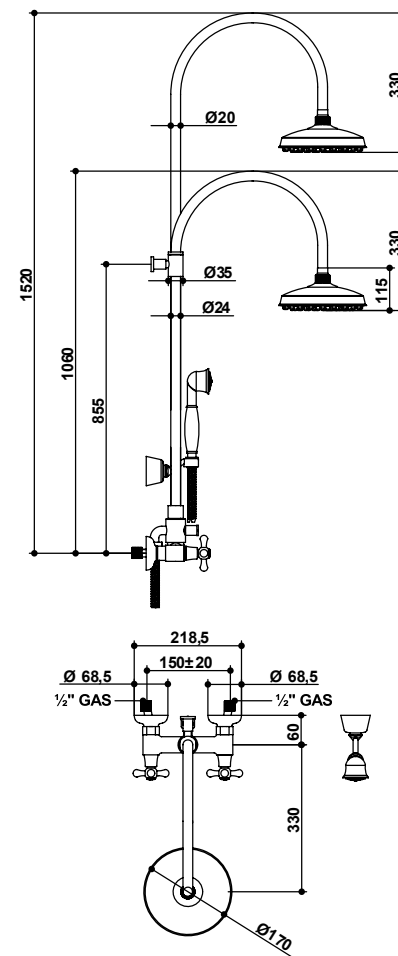

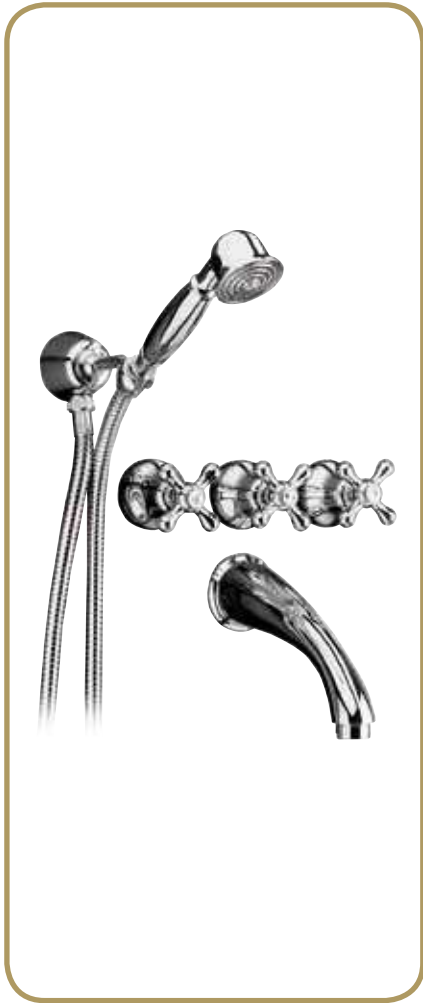

15530/D

Gruppo vasca incasso
con set doccia duplex
*Built-in bath and shower mixer
with duplex shower set*

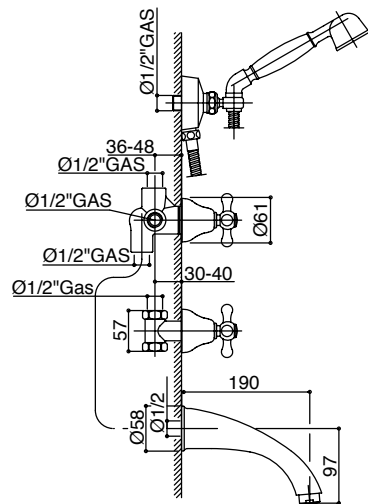

15531/D

Gruppo bordo vasca cinque fori
Five holes deck bath and shower mixer

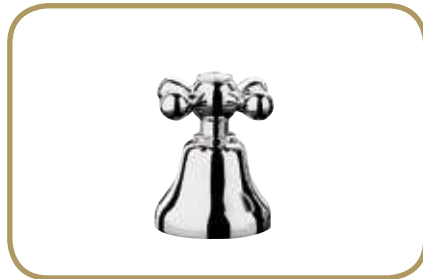
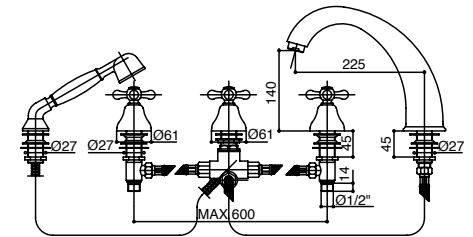

15500

Rubinetto incasso 1/2"
1/2" built-in tap

15498

Rubinetto incasso 3/4"
3/4" built-in tap

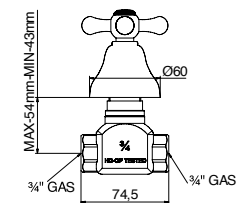
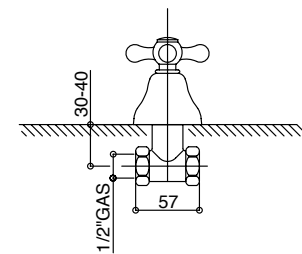



15525

Deviatore 4 vie
(2 entrate - 2 uscite)

*4 ways diverter
(2 in - 2 out)*

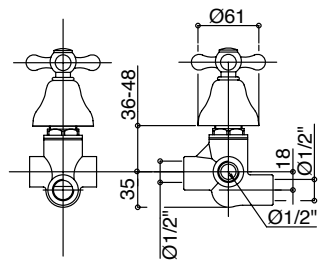

15544

Termostatico doccia incasso 1/2"

1/2" built-in shower thermostatic mixer

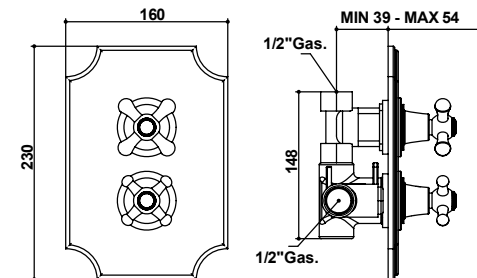

15525/5

Deviatore 5 vie
(2 entrate - 3 uscite)

*5 ways diverter
(2 in - 3 out)*

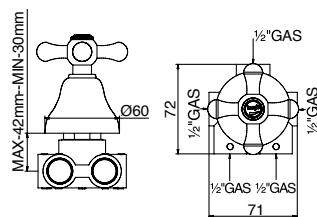

15523

Gruppo doccia esterno

External shower mixer

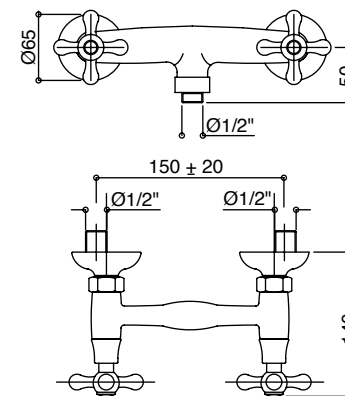

COCÒ





16501

Batteria lavabo tre fori completa di scarico 1.1/4"

Three holes basin mixer with 1.1/4" pop-up waste

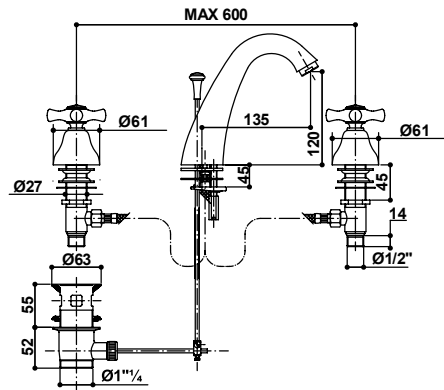

16503

Batteria bidet tre fori con bocca completa di scarico 1.1/4"

Three holes bidet mixer with spout and 1.1/4" pop-up waste

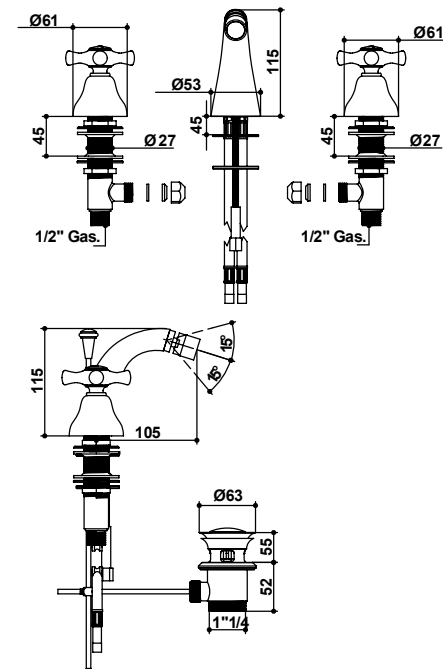

16502/D

Batteria bidet tre fori completa di scarico 1.1/4" e doccia

Three holes bidet mixer with shower and 1.1/4" pop-up waste

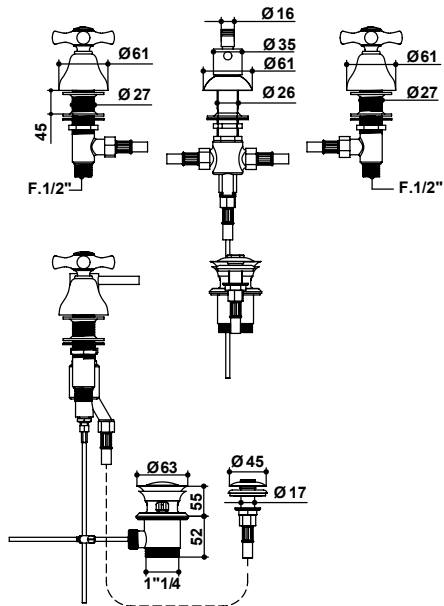

16521

Monoforo lavabo completo di scarico 1.1/4"

Basin monobloc with 1.1/4" pop-up waste

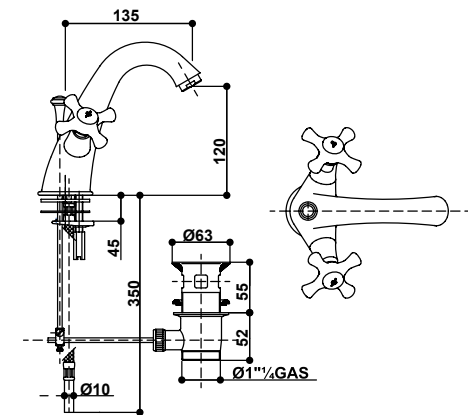



16522

Monoforo bidet completo
di scarico 1.1/4"

*Bidet monobloc with
1.1/4" pop-up waste*

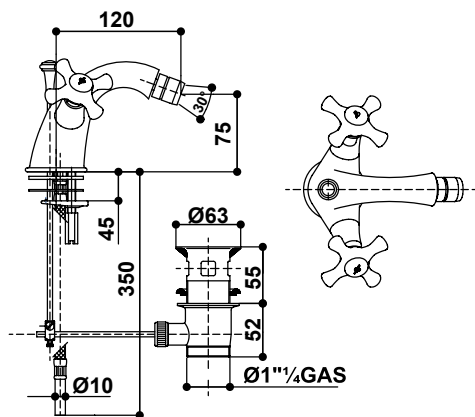

16526

Gruppo vasca esterno
con set doccia

*External bath and shower
mixer with shower set*

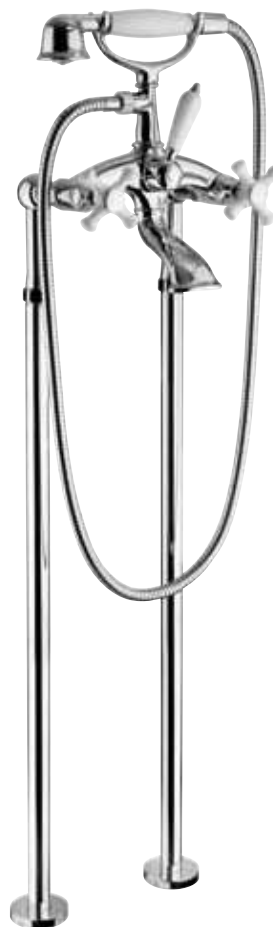
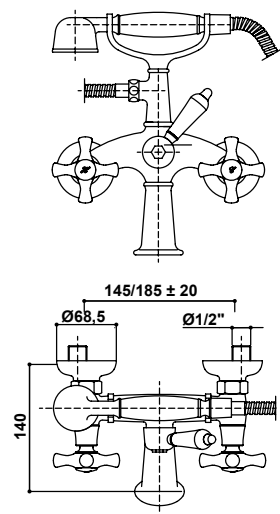

16528

Gruppo vasca esterno su
colonnette da terra con set doccia

*External bath and shower
mixer to the floor with shower set*

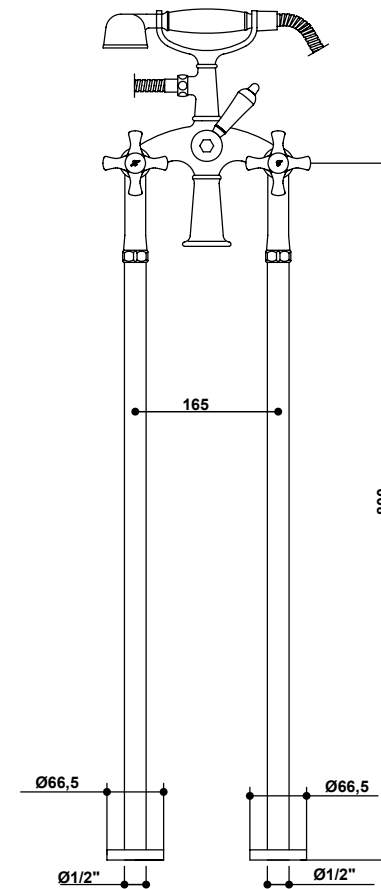



16527

Gruppo vasca con colonnette
bordo vasca e set doccia

*External bath and shower
mixer with shower set on deck legs*

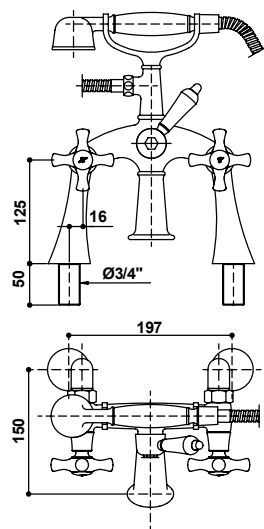

16537/D

Gruppo doccia esterno con tubo,
soffione e set doccia duplex

*External shower mixer with tube,
hower head and shower set duplex*

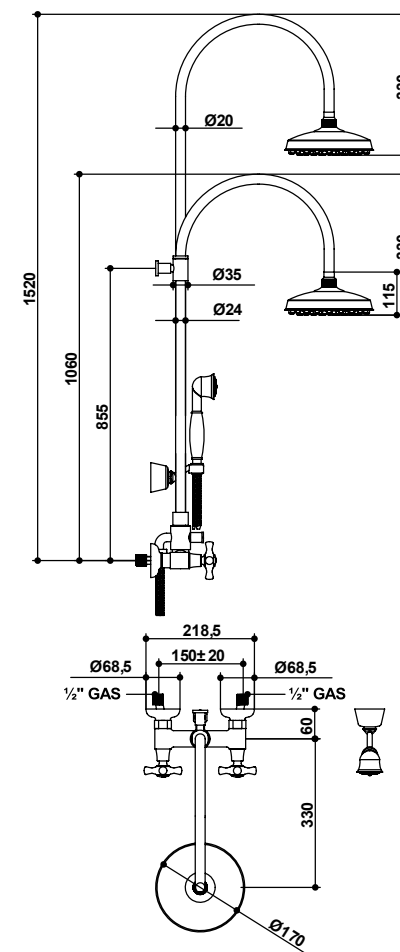



16530/D
 Gruppo vasca incasso con set doccia duplex
Built-in bath and shower mixer with duplex shower set

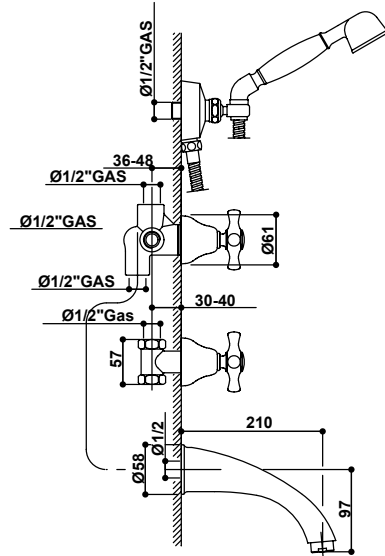

16531/D
 Gruppo bordo vasca cinque fori
Five holes deck bath and shower mixer

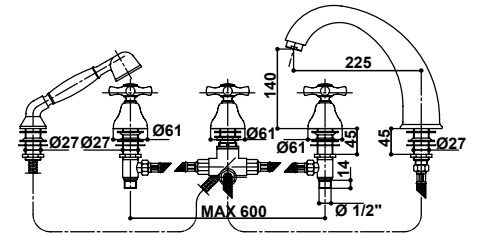

16500
 Rubinetto incasso 1/2"
1/2" built-in tap

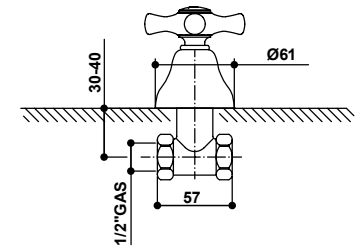

16498
 Rubinetto incasso 3/4"
3/4" built-in tap

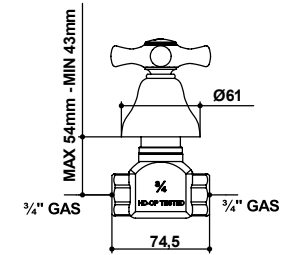



16525

Deviatore 4 vie
(2 entrate - 2 uscite)

*4 ways diverter
(2 in - 2 out)*

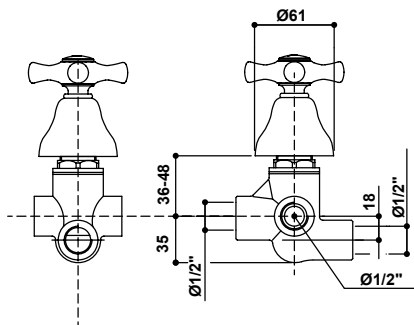

16544

Termostatico doccia incasso 1/2"

*1/2" built-in shower
thermostatic mixer*

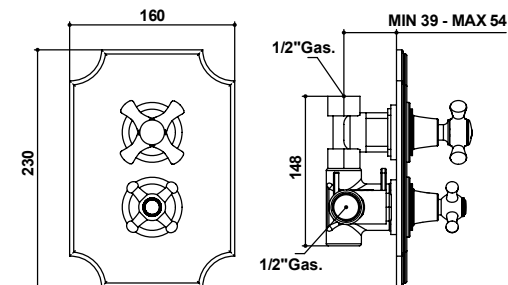

16525/5

Deviatore 5 vie
(2 entrate - 3 uscite)

*5 ways diverter
(2 in - 3 out)*

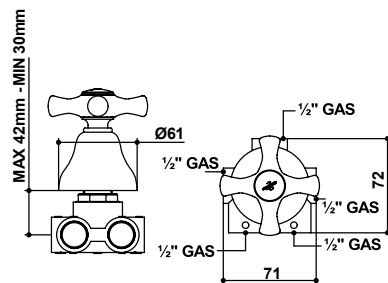

16523

Gruppo doccia esterno

External shower mixer

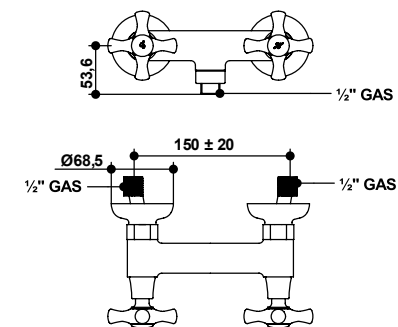

OXFORD LUX



MILLE NUITS





19501 OXFORD LUX
22501 MILLE NUTTS
 Batteria lavabo tre fori completa
 di scarico 1.1/4" bocca bassa
*Three holes basin mixer
 with 1.1/4" pop-up waste*

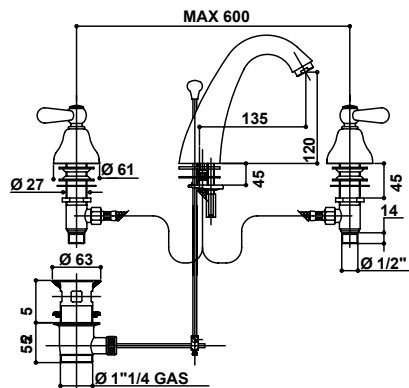

19503 OXFORD LUX
22503 MILLE NUTTS
 Batteria bidet tre fori con bocca
 completa di scarico 1.1/4"
*Three holes bidet mixer with spout
 and 1.1/4" pop-up waste*

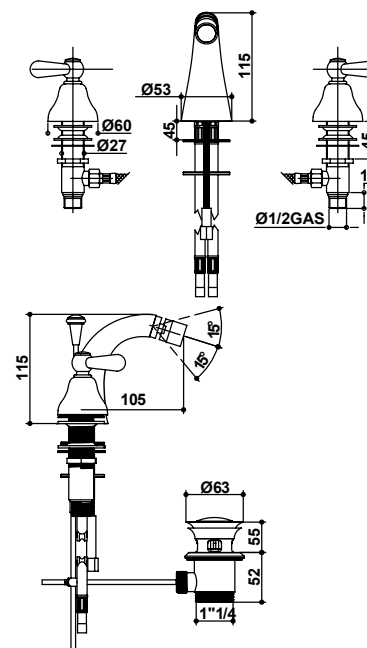

19502/D OXFORD LUX
22502/D MILLE NUTTS
 Batteria bidet tre fori completa
 di scarico 1.1/4" e doccia
*Three holes bidet mixer with shower
 and 1.1/4" pop-up waste*

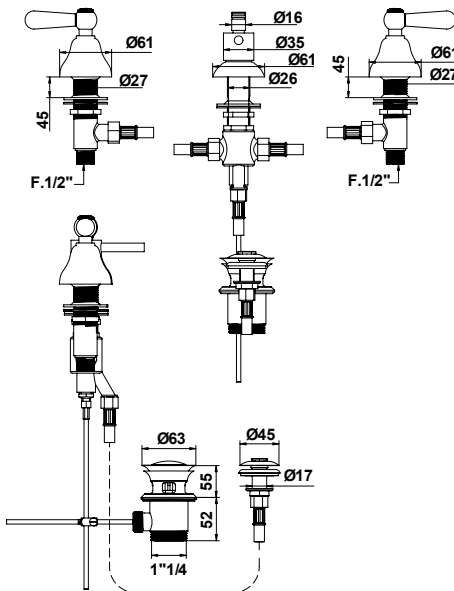

19521 OXFORD LUX
22521 MILLE NUTTS
 Monoforo lavabo completo
 di scarico 1.1/4"
*Basin monobloc with
 1.1/4" pop-up waste*

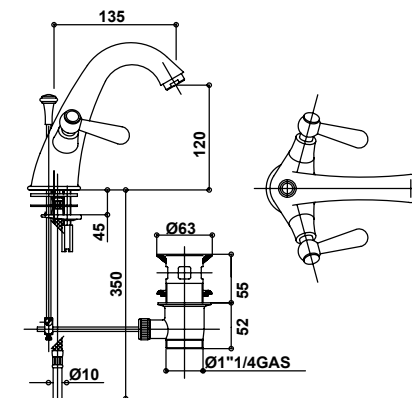

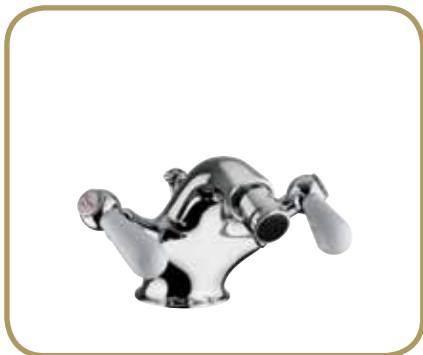

19522 OXFORD LUX
22522 MILLE NUIITS
Monoforo bidet completo
di scarico 1.1/4" Bidet monobloc with
1.1/4" pop-up waste

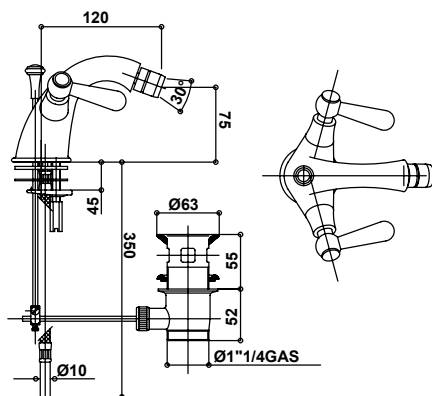

19526 OXFORD LUX
22526 MILLE NUIITS
Gruppo vasca esterno
con set doccia
*External bath and shower mixer
with shower set*

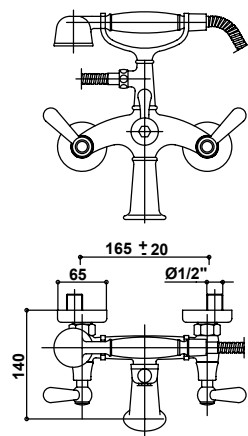

19528 OXFORD LUX
22528 MILLE NUIITS
Gruppo vasca esterno su colonnetta
da terra con set doccia
*External bath and shower mixer
to the floor with shower set*

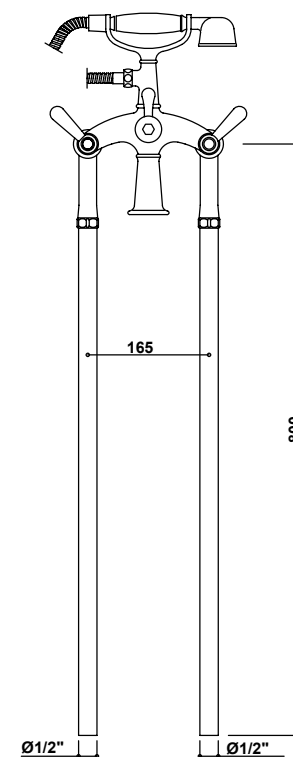



19527 OXFORD LUX
22527 MILLE NUI TS

Gruppo vasca con colonnette
bordo vasca e set doccia

*External bath and shower mixer
with shower set on deck legs*

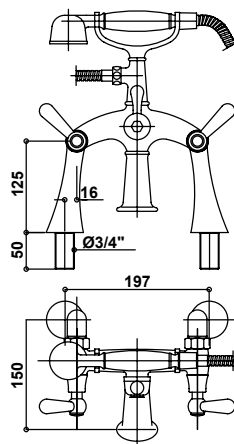

19537/D OXFORD LUX
22537/D MILLE NUI TS

Gruppo doccia esterno con tubo,
soffione e set doccia duplex

*External shower mixer with tube,
shower head and shower set duplex*

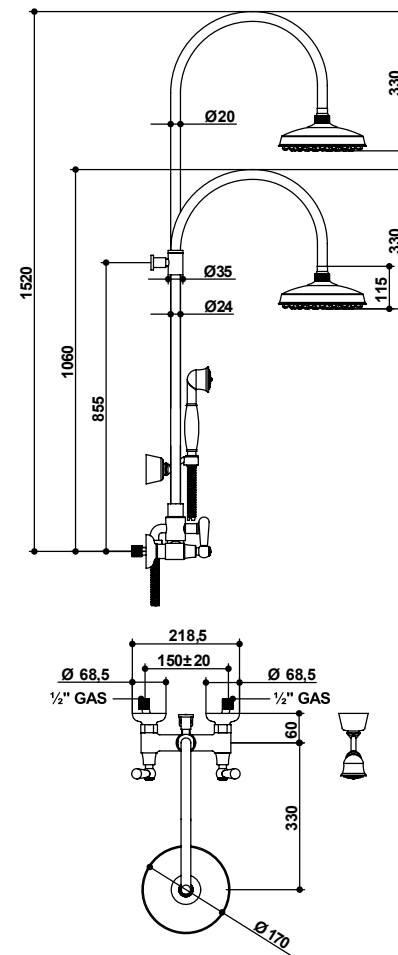



19530/D OXFORD LUX
22530/D MILLE NUITS
Gruppo vasca incasso
con set doccia duplex
*Built-in bath and shower
mixer with duplex shower set*

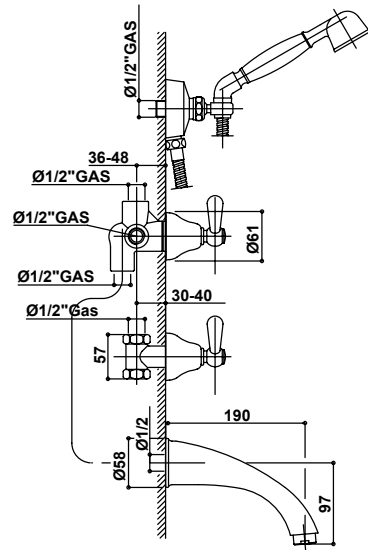

19531/D OXFORD LUX
22531/D MILLE NUITS
Gruppo bordo vasca cinque fori
Five holes deck bath and shower mixer

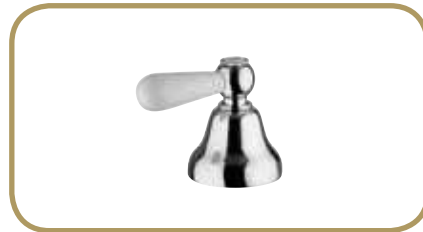
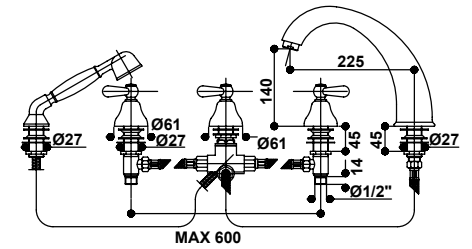

19500 OXFORD LUX
22500 MILLE NUITS
Rubinetto incasso 1/2"
1/2" built-in tap

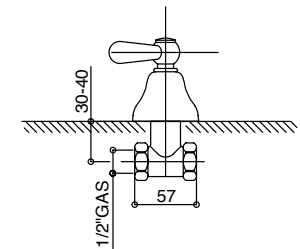

19498 OXFORD LUX
22498 MILLE NUITS
Rubinetto incasso 3/4"
3/4" built-in tap

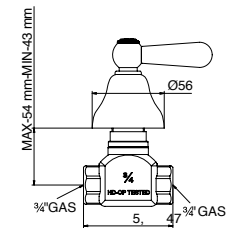



19525 OXFORD LUX
22525 MILLE NUTTS
Deviatore 4 vie
(2 entrate - 2 uscite)
*4 ways diverter
(2 in - 2 out)*

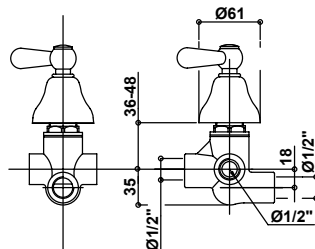

19544 OXFORD LUX
22544 MILLE NUTTS
Termostatico doccia incasso 1/2"
*1/2" built-in shower
thermostatic mixer*

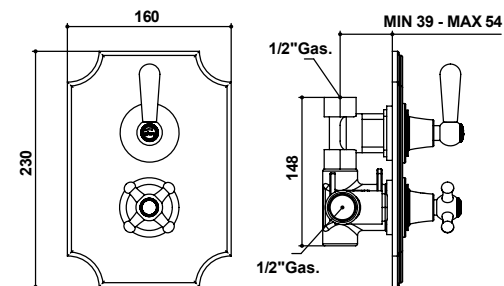

19525/5 OXFORD LUX
22525/5 MILLE NUTTS
Deviatore 5 vie
(2 entrate - 3 uscite)
*5 ways diverter
(2 in - 3 out)*

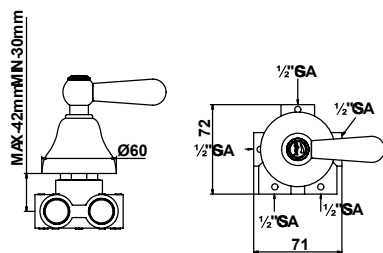

19523 OXFORD LUX
22523 MILLE NUTTS
Gruppo doccia esterno
External shower mixer

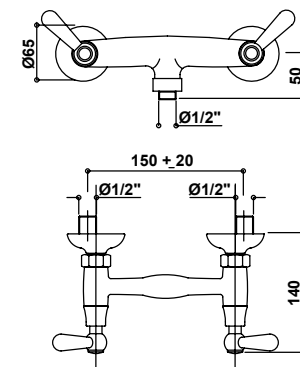

ZENITH

MADE WITH SWAROVSKI® ELEMENTS





23501/B

Batteria lavabo tre fori completa di scarico 1.1/4" bocca bassa
Three holes basin mixer with short spout and 1.1/4" pop-up waste

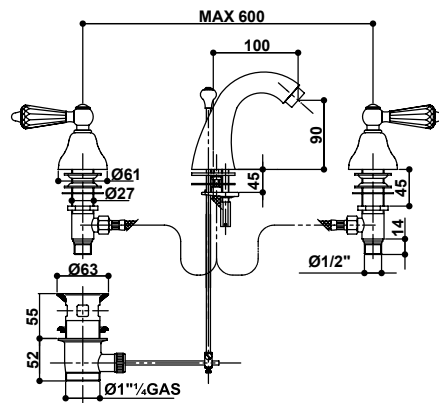

23503

Batteria bidet tre fori con bocca completa di scarico 1.1/4"
Three holes bidet mixer with 1.1/4" spout and 1.1/4" pop-up waste

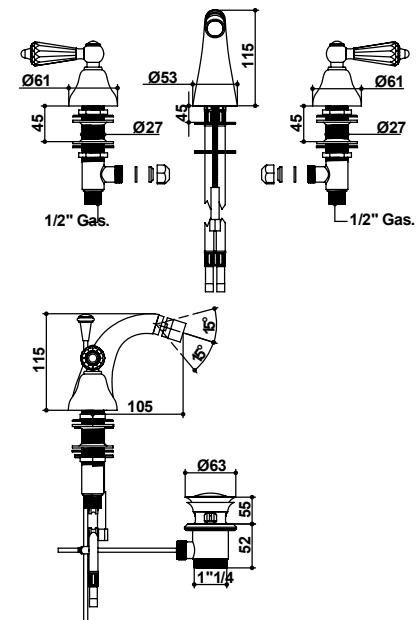

23502/D

Batteria bidet tre fori completa di scarico 1.1/4" e doccia
Three holes bidet mixer with shower and 1.1/4" pop-up waste

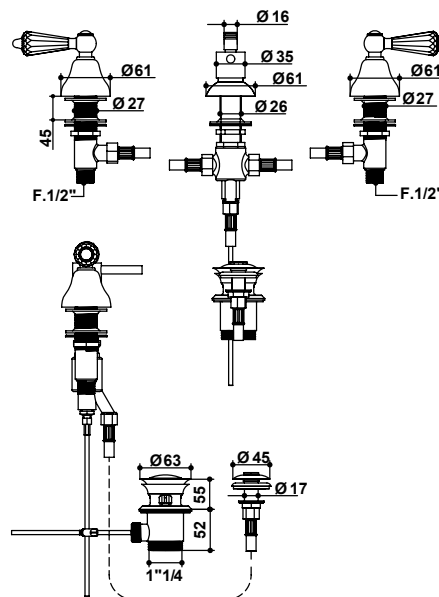

23521

Monoforo lavabo completo di scarico 1.1/4"
Basin monobloc with 1.1/4" pop-up waste

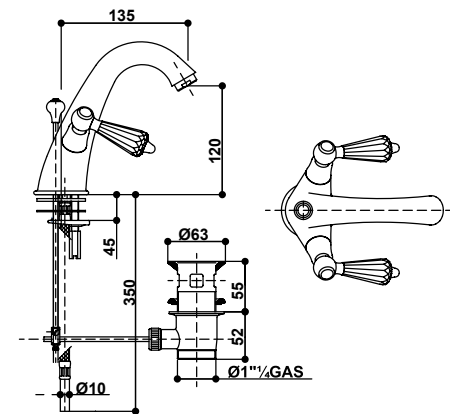



23522

Monoforo bidet completo
di scarico 1.1/4"

*Bidet monobloc with
1.1/4" pop-up waste*

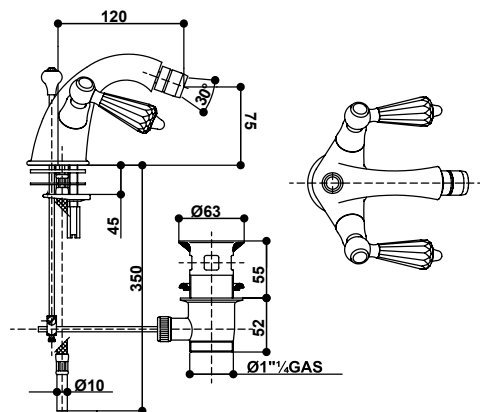

23526

Gruppo vasca esterno
con set doccia

*External bath and shower
mixer with shower set*

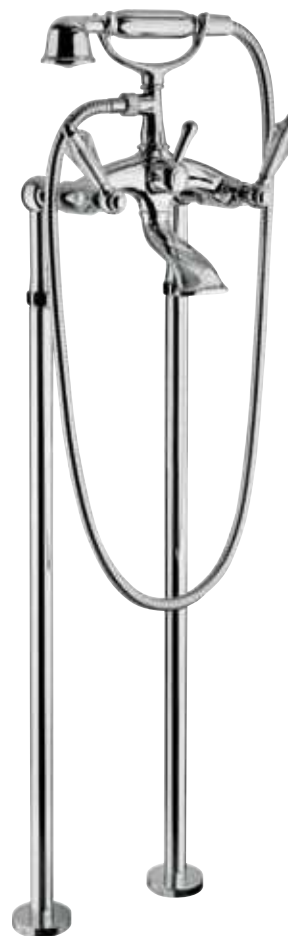
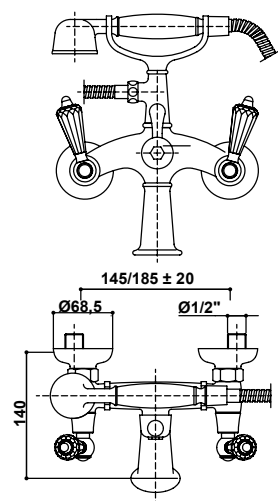

23528

Gruppo vasca esterno su
colonnette da terra con set doccia

*External bath and shower mixer
to the floor with shower set*

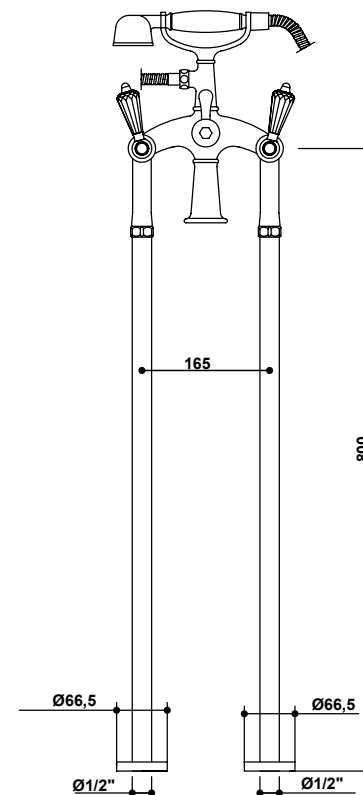



23527

Gruppo vasca con colonnette
bordo vasca e set doccia

*External bath and shower
mixer with shower set on deck legs*

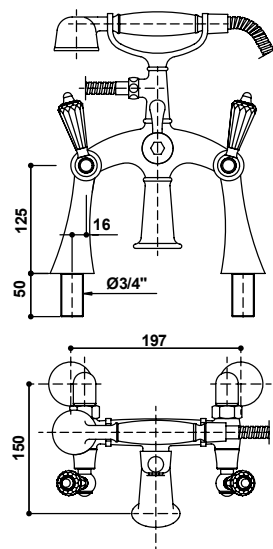

23537/D

Gruppo doccia esterno con tubo,
soffione e set doccia duplex

*External shower mixer with tube,
shower head and shower set duplex*

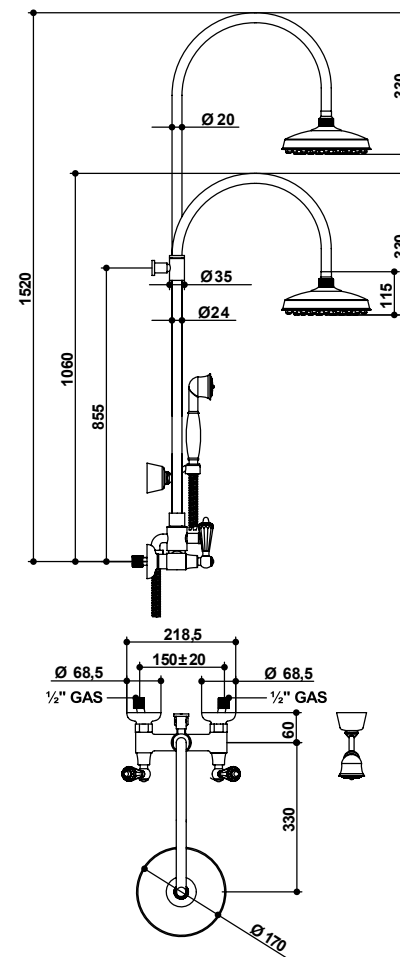



23530/D

Gruppo vasca incasso
con set doccia duplex
*Built-in bath and shower mixer
with duplex shower set*

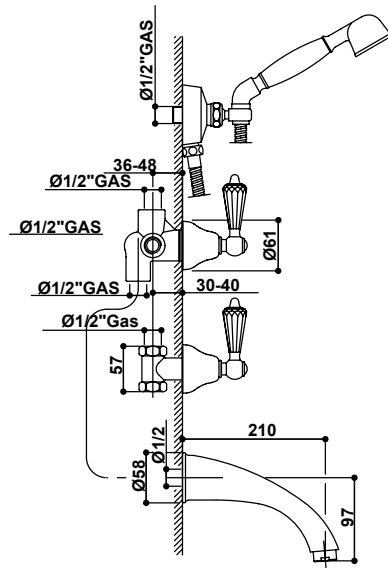

23531/D

Gruppo bordo vasca cinque fori
Five holes deck bath and shower mixer

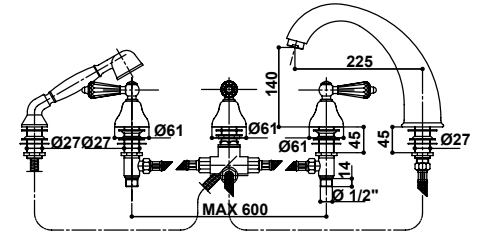

03500

Rubinetto incasso 1/2\"/>
1/2\" built-in tap

03498

Rubinetto incasso 3/4\"/>
3/4\" built-in tap

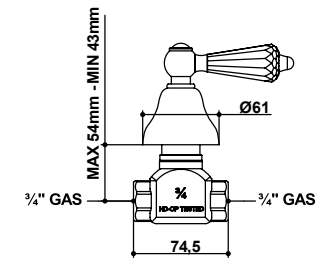
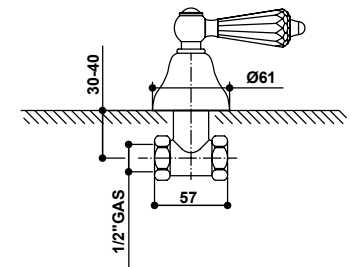



23525
 Deviatore 4 vie
 (2 entrate - 2 uscite)
*4 ways diverter
 (2 in - 2 out)*

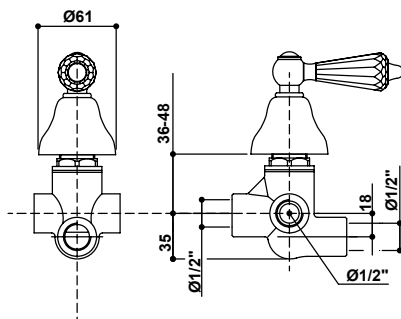

23544
 Termostatico doccia incasso 1/2"
*1/2" built-in shower
 thermostatic mixer*

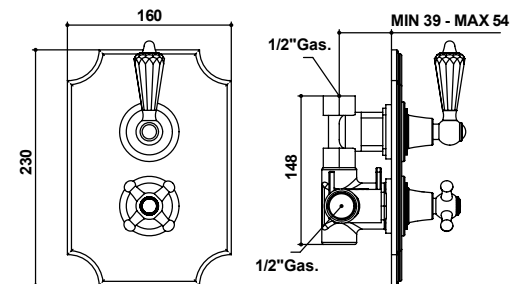

23525/5
 Deviatore 5 vie
 (2 entrate - 3 uscite)
*5 ways diverter
 (2 in - 3 out)*

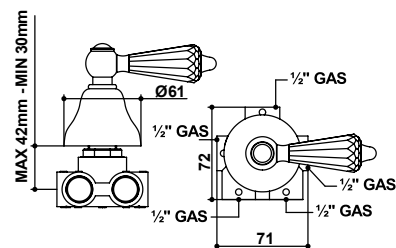

23523
 Gruppo doccia esterno
External shower mixer

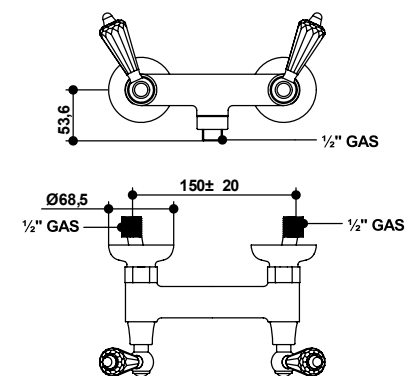

ACCESSORI

ACCESSORIES

114

bongio





DUOMO - Milan - Italy

ACCESSORI COLLEZIONE IMPERO



06001
Porta abito
Robe hook

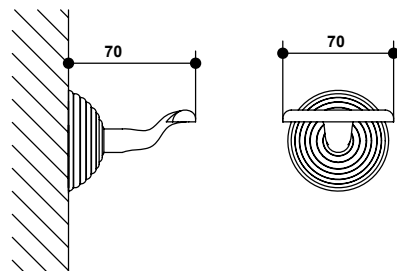

06004
Porta asciugamano ad anello
Towel ring holder

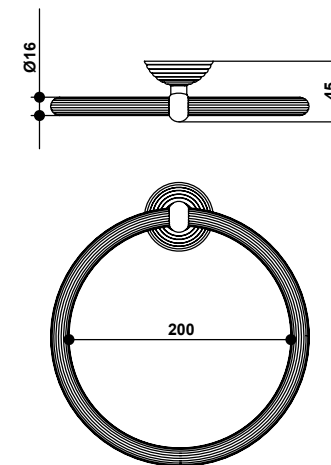

116



06007/5
Porta asciugamano mm 500
500 mms towel rail

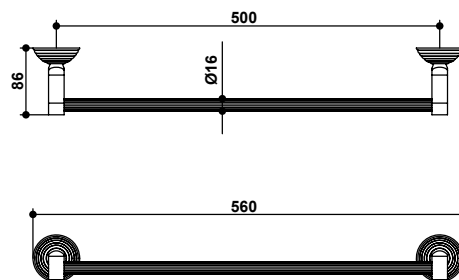

06008
Porta rotolo con ribalta
Paper holder with flap

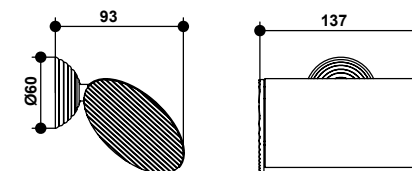

Accessori da abbinare alla serie IMPERO - Accessories to combine with IMPERO collection

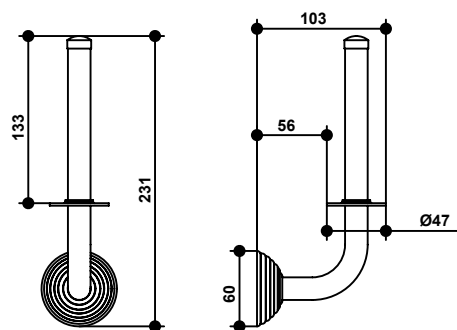

06010
Porta rotolo di riserva
Toilet paper holder with supply

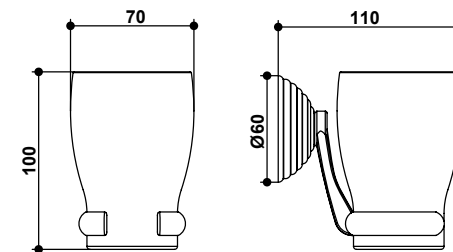

06014
Porta bicchiere
Glass holder

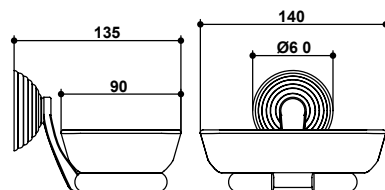

06015
Porta sapone
Soap holder

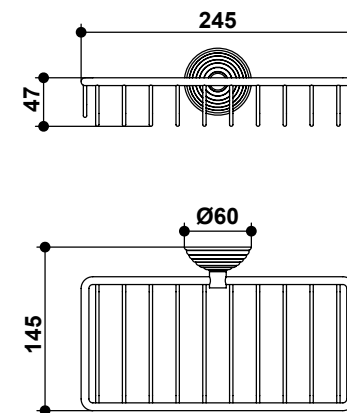
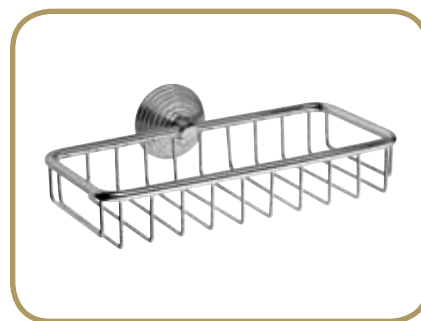

06013
Cestello rettangolare
Rectangular basket

ACCESSORI COLLEZIONE FLEUR



11001
Porta abito
Robe hook

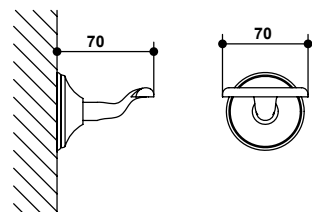

11011
Porta asciugamano ad anello
Towel ring holder

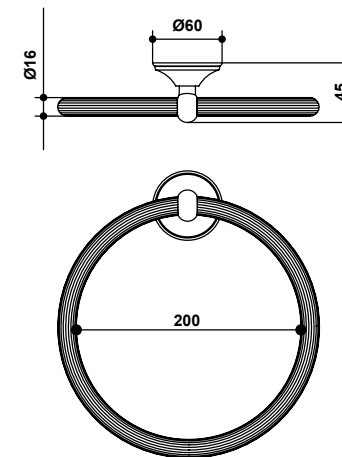

118



11007/5
Porta asciugamano mm 500
500 mms towel rail



11008
Porta rotolo con ribalta
Paper holder with flap

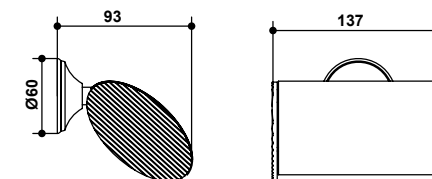

Accessori da abbinare alle serie CRISTALLO, FLEUR BLANC & FLEUR NOIR
Accessories to combine with CRISTALLO, FLEUR BLANC & FLEUR NOIR collection

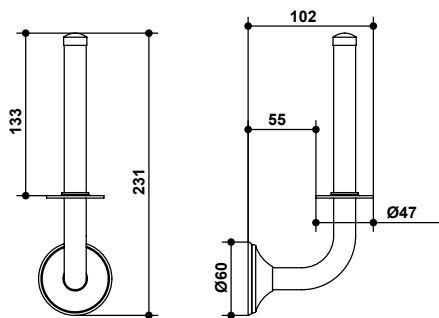

11010
Porta rotolo di riserva
Toilet paper holder with supply

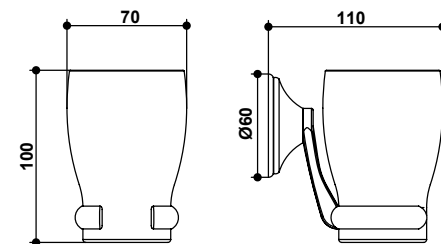

11014
Porta bicchiere
Glass holder

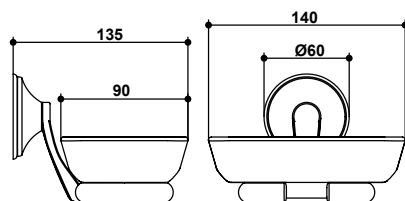

11015
Porta sapone
Soap holder

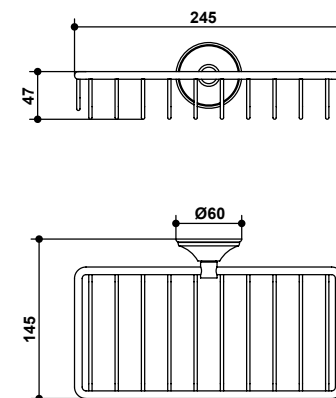

11013
Cestello rettangolare
Rectangular basket

ACCESSORI COLLEZIONE RADIANT



02001
Porta abito
Robe hook

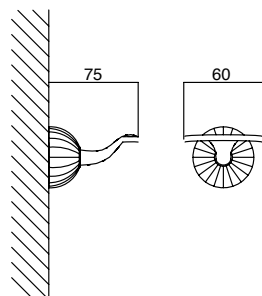

02004
Porta asciugamano ad anello
Towel ring holder

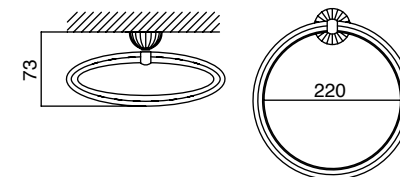

120



02007/5
Porta asciugamano mm 500
500 mms towel rail

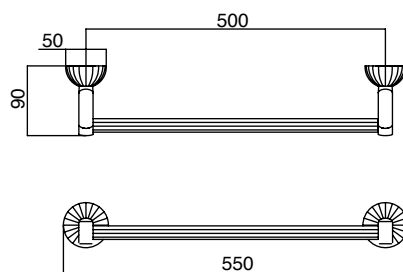

02008
Porta rotolo con ribalta
Paper holder with flap

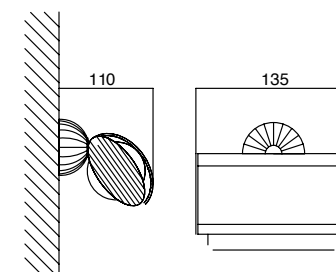

Accessori da abbinare alle serie RADIANT & RIVOLÌ - *Accessories to combine with RADIANT & RIVOLÌ collection*

CLASSICA DI BONGIO



02009
Porta rotolo di riserva
Toilet paper holder with supply

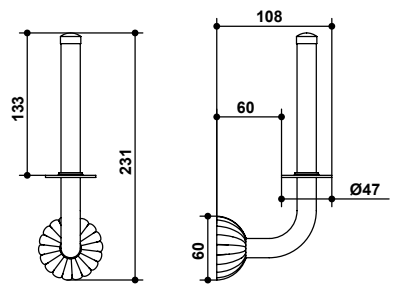

02014
Porta bicchiere
Glass holder

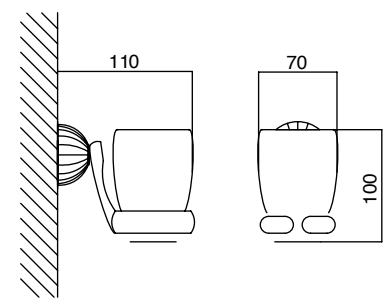

02015
Porta sapone
Soap holder

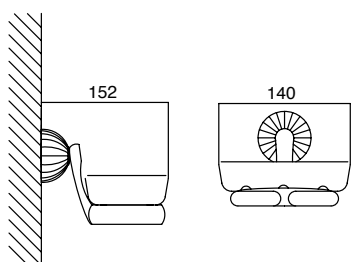

02013
Cestello rettangolare
Rectangular basket

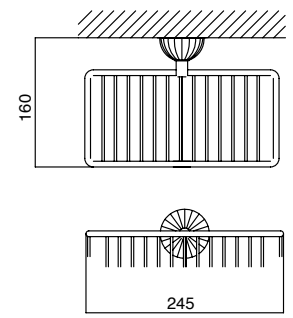

ACCESSORI COLLEZIONE AXEL

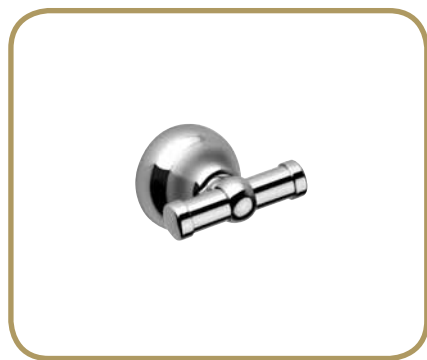

15001
Porta abito
Robe hook

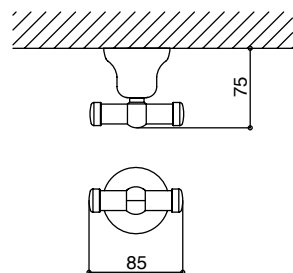

15004
Porta asciugamano ad anello
Towel ring holder

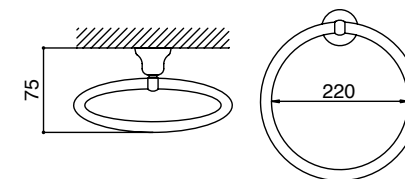

122

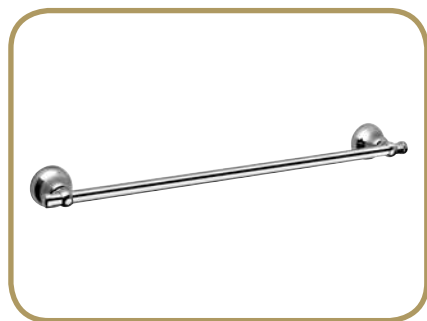

15007/6
Porta asciugamano mm 500
500 mms towel rail

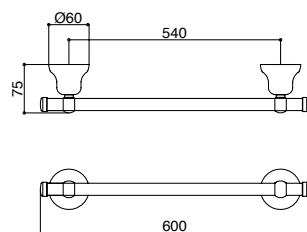

15008
Porta rotolo con ribalta
Paper holder with flap

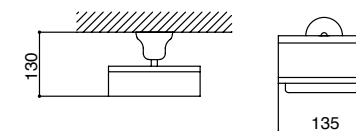

Accessori da abbinare alle serie AXEL, OXFORD LUX, COCO, CAPRI, MILLE NUITS & ZENITH
Accessories to combine with AXEL, OXFORD LUX, COCO, CAPRI, MILLE NUITS & ZENITH collection



15011
Porta rotolo di riserva
Toilet paper holder with supply

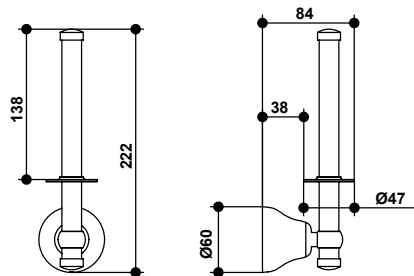

15014
Porta bicchiere
Glass holder

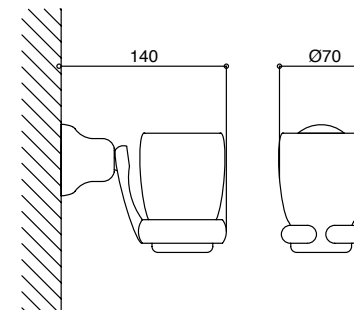

15015
Porta sapone
Soap holder

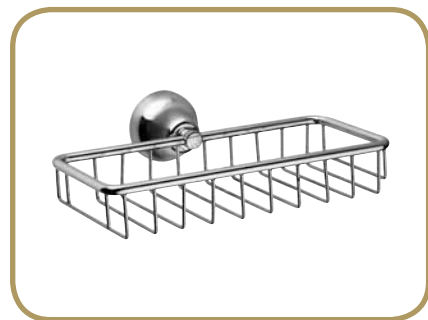
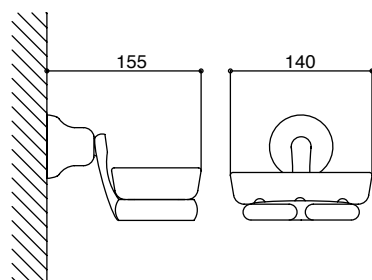

15013
Cestello rettangolare
Rectangular basket

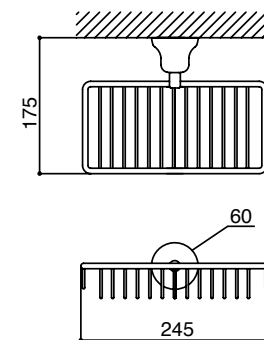



21025
 Porta scopino da appoggio
Toilet brush holder to lean

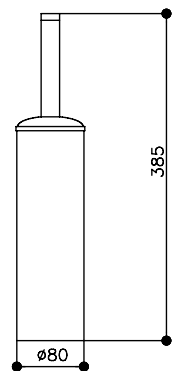

15025
 Porta scopino con vaso
 in vetro satinato
Toilet brush holder with matt glass

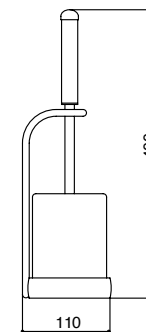

15030
 Specchio ovale mm 740x540
740x540 mms oval mirror

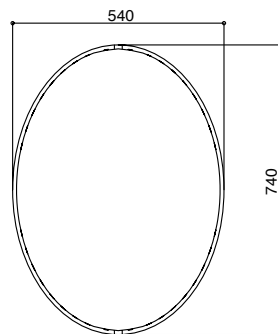

DOCCE E COMPLEMENTI

SHOWER & COMPLEMENTS



bongio



15891
Bocca incasso a cascata classica
Classical built-in bath spout

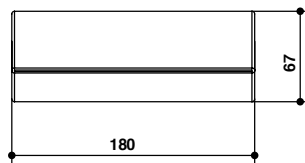
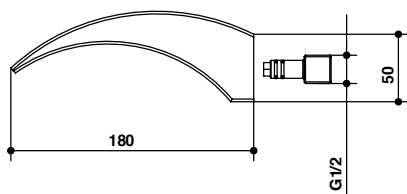

15892
Bocca a cascata classica
bordo vasca
Classical deck bath spout

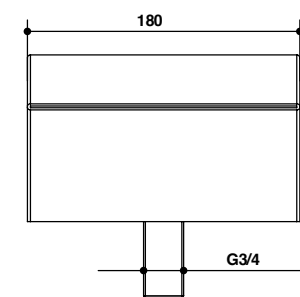
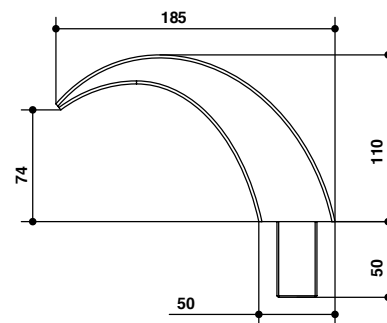



988
 Bocca fusa incasso 1/2F mm. 190
*Built-in cast spout, 1/2F,
 190 mms. long*

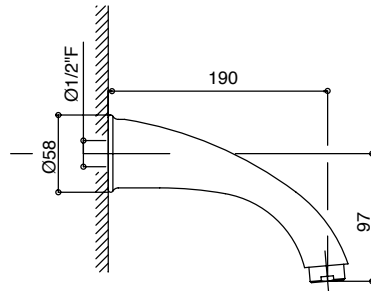

15906
 Bocca alta lavabo
Basin high spout

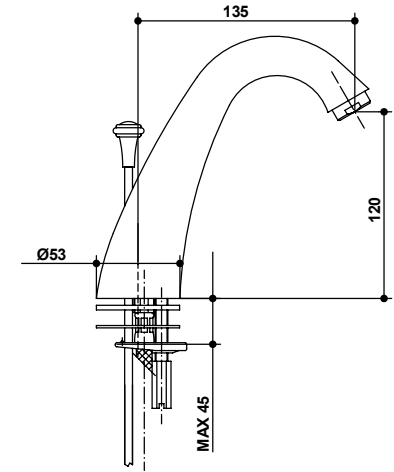

15908
 Bocca bassa lavabo
Basin short spout

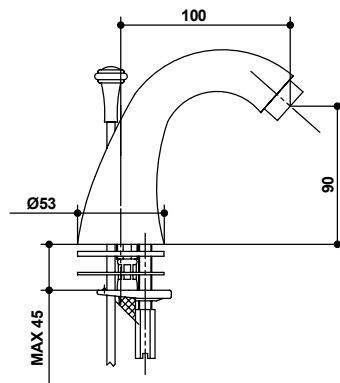

15905
 Bocca bidet
Bidet spout

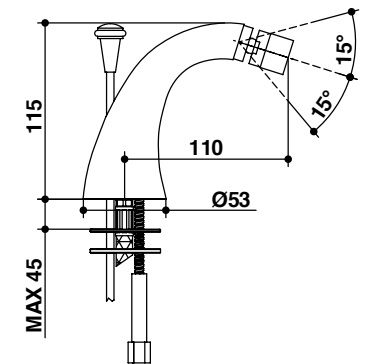



871

Saliscendi classico in ottone con doccetta monogetto e flessibile doppia aggraffatura 1500 mm, 1/2" FF conico

Brass classic sliding rail with single function handshower and 1500 mms double interlock hose, 1/2" FF conical

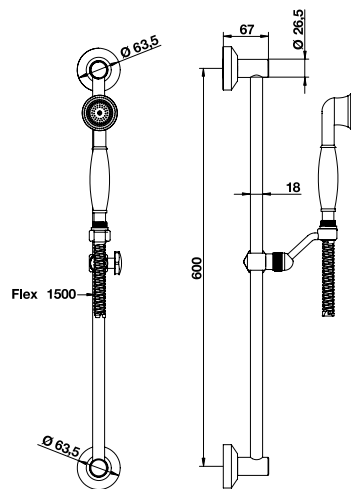

831

Duplex con erogazione in ottone con supporto orientabile, doccetta monogetto e flessibile doppia aggraffatura 1500 mm, 1/2" FF conico

Brass shower set with water supply elbow with orientable bracket, single function handshower and 1500 mms double interlock hose, 1/2" FF conical

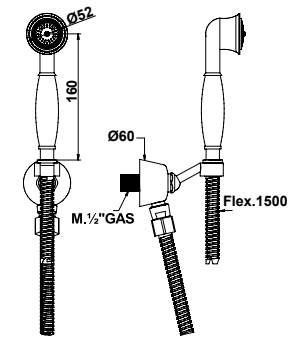

821

Duplex senza erogazione in ottone con supporto orientabile, doccetta monogetto e flessibile doppia aggraffatura 1500 mm, 1/2" FF conico

Brass shower set with orientable bracket, single function handshower and 1500 mms double interlock hose, 1/2" FF conical



971

Saliscendi classico in ottone con doccetta monogetto e flessibile doppia aggraffatura 1500 mm, 1/2" FF conico

Brass classic sliding rail with single function handshower and 1500 mms double interlock hose, 1/2" FF conical

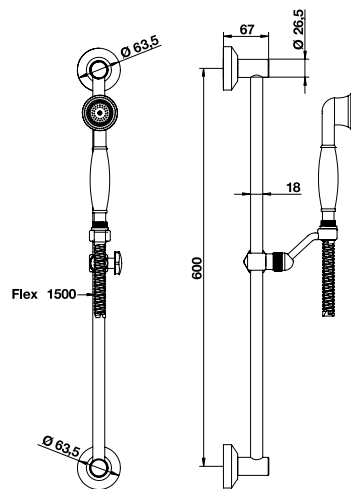

837

Duplex con erogazione in ottone con supporto orientabile, doccetta monogetto e flessibile doppia aggraffatura 1500 mm, 1/2" FF conico

Brass shower set with water supply elbow with orientable bracket, single function handshower and 1500 mms double interlock hose, 1/2" FF conical

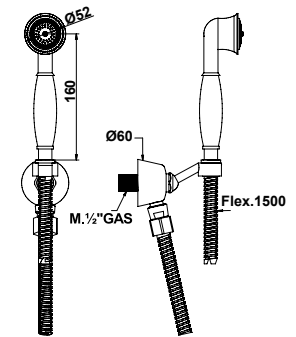

827

Duplex senza erogazione in ottone con supporto orientabile, doccetta monogetto e flessibile doppia aggraffatura 1500 mm, 1/2" FF conico

Brass shower set with orientable bracket, single function handshower and 1500 mms double interlock hose, 1/2" FF conical

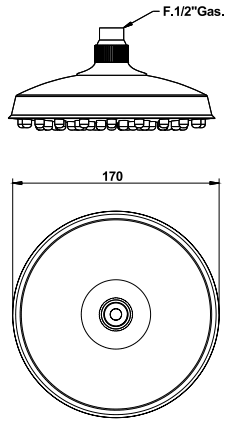

860
 Soffione 48 getti Ø mm 170
 in ottone
*Ø 170 mms brass shower
 head with 48 holes*

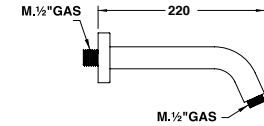

803
 Braccio doccia mm 220 in ottone
220 mms brass shower arm

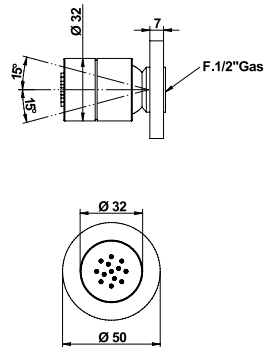

867/RO
 Soffioncino laterale tondo in ottone,
 orientabile, getto pioggia
*Orientable brass body
 spray shower, rain function*

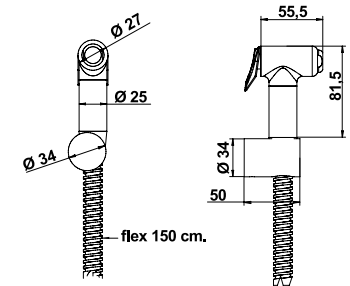

902
 Set a muro tondo
 in ottone per wc
Round brass shower set for wc

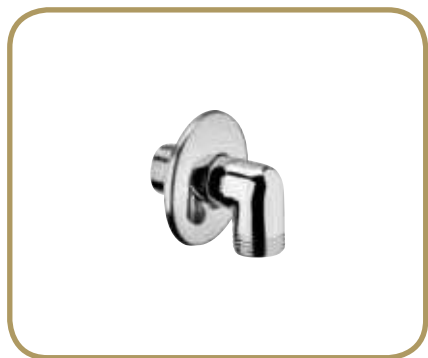

898

Pres a d'acqua classica
in ottone con rosone
Wall water connection

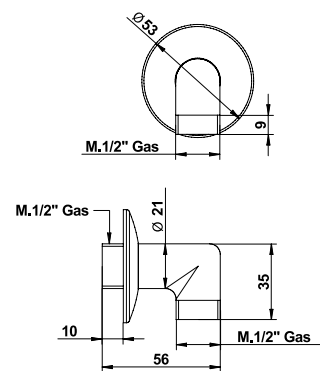

Condizioni generali di vendita

Le presenti condizioni generali disciplinano tutti gli attuali e futuri contratti fra le parti, salvo eventuali deroghe concordate per iscritto. Eventuali condizioni generali del compratore non troveranno applicazione nei rapporti futuri tra le parti se non espressamente accettate per iscritto dalla Mario Bongio srl.

1. Formazione del contratto

L'invio da parte del compratore di un ordine al venditore comporta l'applicazione al contratto di vendita delle presenti condizioni generali. Il venditore si riserva il diritto di accettare o rifiutare l'ordine ricevuto. Le offerte fatte da agenti, rappresentanti ed ausiliari del commercio del venditore non sono per lui impegnative fino a quando non siano confermate dal venditore stesso.

2. Prezzi

I prezzi indicati nel listino sono indicati in euro e ad essi deve essere applicata l'i.v.a. secondo l'aliquota in vigore al momento della fatturazione. Il venditore si riserva di modificare i prezzi, o variare il listino prezzi senza alcun preavviso.

3. Resa della merce

Salvo patto contrario, la fornitura dei prodotti si intende Franco Fabbrica del venditore: trasporto ed assicurazione sono pertanto a carico del compratore e ciò anche quando sia convenuto che la spedizione o parte di essa venga curata dal venditore, nel qual caso quest'ultimo agirà come mandatario del compratore, essendo inteso che il trasporto verrà effettuato a rischio del compratore.

I rischi relativi alla fornitura passano al compratore al momento in cui i prodotti lasciano lo stabilimento del venditore.

4. Termini di consegna

I termini di consegna indicati sulle conferme d'ordine, si intendono approssimativi a favore del venditore e comunque con un congruo margine di tolleranza.

È esclusa qualsiasi responsabilità del venditore per danni derivanti da anticipata, ritardata o mancata consegna, totale o parziale.

Il compratore è sempre tenuto a prendere in consegna i prodotti, anche in caso di consegne parziali e quando i prodotti vengano consegnati prima o successivamente alla data di consegna stabilita. Il termine di consegna verrà prorogato di un periodo pari a quello della durata dell'impedimento al verificarsi di cause di forza maggiore. In nessun caso, a causa del verificarsi di tali circostanze, il compratore potrà esigere compensi o indennizzi di qualsiasi natura.

5. Garanzia

Il venditore garantisce la conformità dei prodotti forniti; con il termine di conformità dei prodotti si intende che essi corrispondono per qualità, quantità e tipo a quanto stabilito nel contratto e che sono esenti da vizi che potrebbero renderli non idonei all'uso cui sono destinati. La garanzia per vizi è limitata ai soli difetti dei prodotti conseguenti a difetti di progettazione, di materiale o di

costruzione riconducibili al venditore, e non si applica nel caso in cui il compratore non abbia effettuato una corretta conservazione dei prodotti e li abbia modificati senza il consenso del venditore.

Il venditore non risponde dei difetti di conformità dei prodotti dovuti all'usura normale di quelle parti che, per loro natura sono soggette a usura rapida e continua. Per ogni altra precisazione si rimanda al libretto di garanzia presente nei nostri articoli.

6. Reclami

Il compratore è tenuto a verificare la conformità dei prodotti e l'assenza di vizi. I reclami relativi a non conformità dei prodotti forniti dovranno essere effettuati, a pena di decadenza, entro e non oltre cinque giorni dal ricevimento della merce a destino. I vizi, difetti o non conformità occulti devono essere denunciati immediatamente alla loro scoperta e comunque, a pena di decadenza, entro e non oltre i tre mesi dalla data di consegna. Tutti i reclami devono essere effettuati mediante lettera raccomandata indirizzata al venditore e devono indicare dettagliatamente i vizi e le non conformità contestate.

7. Rimedi

In caso di prodotti non conformi, e dopo aver ricevuto un rapporto dettagliato dal compratore, il venditore potrà, a sua insindacabile scelta:

- a) fornire gratuitamente Franco Fabbrica al compratore prodotti dello stesso genere e quantità di quelli risultanti difettosi o non conformi a quanto pattuito, dopo averne ottenuto la resa per la verifica. L'eventuale sostituzione effettuata prontamente dal venditore non può essere ritenuta un implicito riconoscimento dei vizi contestati. Qualora il venditore, in sede di verifica, non riconosca viziati i prodotti, provvederà alla fatturazione di quelli inviati in sostituzione; oppure
- b) emettere una nota di accredito a favore del compratore per un importo corrispondente al valore dei prodotti difettosi.

In entrambi i casi il venditore ha diritto alla restituzione dei prodotti difettosi, che diventano di sua proprietà.

8. Limitazione di responsabilità del venditore

Salvo dolo o colpa grave del venditore l'eventuale risarcimento di qualsiasi danno al compratore non potrà comunque superare il prezzo di fattura dei prodotti contestati.

9. Resi

I resi di merce da parte dei committenti dovranno sempre comunque essere autorizzati per iscritto dalla nostra sede. I resi preventivamente autorizzati devono giungere alla fornitrice franco magazzino di San Maurizio d'Opaglio in buon ordine e negli imballaggi originali. L'accredito per le merci rese sarà stilato ad avvenuta presa in carico del nostro magazzino e controllo. Danni ai prodotti ed agli imballaggi saranno defalcati dall'accredito.

10. Pagamento

I pagamenti ed ogni altra somma dovuta a qualsiasi titolo al venditore si intendono netti al suo domicilio. Qualsiasi ritardo o irregolarità nel pagamento da al venditore il diritto di sospendere le forniture o di risolvere contratti in corso, anche non relativi ai pagamenti in questione, nonché il diritto al risarcimento degli eventuali danni. Il venditore ha altresì il diritto a decorrere dalla scadenza del pagamento, agli interessi moratori nella misura stabilita in Italia dall'art. 5 del Decreto Legislativo 9 ottobre 2002 n. 231. Il ritardo nei pagamenti dà altresì al venditore il diritto di escludere la garanzia per tutto il periodo durante il quale il ritardo perdura.

11. Riserva di proprietà

I prodotti consegnati restano di proprietà del venditore sino al momento del completo pagamento del prezzo.

12. Legge applicabile e foro competente

Tutti i contratti disciplinati dalle presenti condizioni generali sono regolati dalla legge italiana. Per ogni controversia relativa o comunque collegata a contratti cui si applicano le presenti condizioni generali è escusivamente competente il foro del tribunale di Novara sezione distaccata di Borgomanero.

13. Importo minimo ordini

A causa della notevole incidenza dei costi amministrativi non saranno presi in considerazione ordini di importo inferiore a euro 100,00. Per ordini da euro 100,00 a euro 150,00 viene richiesto un contributo spese forfettario di euro 15,00 per ogni spedizione.

14. Immagini

Le illustrazioni del catalogo sono una rappresentazione di ogni articolo ma non costituiscono impegno di fedele esecuzione. L'azienda si riserva il diritto di effettuare modifiche sia tecniche che estetiche senza preavviso, come pure procedere alla eliminazione di singoli articoli o di serie complete.

General condition for sale

This general conditions regulate all present and future sales contracts between the parties, subject to any exceptions specifically agreed upon in writing. Any general conditions of the purchaser will not apply to future contractual relations between the parties unless expressly accepted in writing by Mario Bongio srl.

1. Formation of the Contract

The purchaser placing the order fully accepts the application of these general terms to the Contract for sale. Seller reserves the right to accept or refuse it. Offers made by Agents, representatives or auxiliaries of the seller do not bind him until they are confirmed by the seller itself.

2. Prices

The price indicated in the price list are in euro and do not include V.A.T or any other tax whatsoever. Seller may modify the prices/price list without prior notice.

3. Delivery of the goods

Unless agreed to the contrary, the supply of the products has intended ex-factory: transport and insurance are therefore at the charge of the purchaser, this also when it has been decided that the delivery or part of it will be taken care of, by the seller, in which case the latest will act as the purchaser's agent, it being understood that the transport will be carried out at the expense and risk of the purchaser. The risks relative to the supply pass to the purchaser, at the latest at the time in which the products leave the seller's plant.

4. Delivery time of the goods

The delivery limits on the order confirmations are agreed approximately in favour of the seller and not binding for him. Any liability of the seller has excluded for damage deriving from anticipated, delayed or non delivery, total or partial.

The purchaser has always held to take delivery of the products, even in the case of partial deliveries and even when the products have been consigned before the established delivery date or successively to that date. The seller shall not be deemed to be in breach of this agreement, or otherwise be liable to the purchaser, by reason of any delay in delivery, to the extent that the delay is due to any Force Majeure, and the time for performance of delivery shall be extended accordingly.

5. Guarantee

The seller guarantees the compliance of the products supplied; the term compliance of the products means the products correspond in quality, quantity and type to what has been agreed in the contract and that they are without defects that could render them unfit for the use to which they are intended to be put. The guarantee against defects has limited only to product defects due to defects in planning, materials or construction that can be attributed to the seller, and it does not apply in the case where the purchaser is

unable to prove a correct preservation of the product and where he has modified them without the agreement of the seller. The seller is not liable for defects in product compliance due to the normal wear of those parts which, by nature, are subject to rapid and continuous wear and tear. See the warranty book enclosed in our packaging for other specifications.

6. Claims

The purchaser has to control the compliance of the products and the absence of flaws. Claims relevant to non-conformities of the goods must be made, on pain of forfeiture, within and not later than five days from the goods arrival at their place of destination. Hidden flaws, defect or non-compliances must be reported immediately after the discovery and in any event, on pain of forfeiture, not later than three months from the delivery date. Claims must be made by registered letter addressed to the seller and must describe in detail the flaws or disputed non-compliances.

7. Remedies

In case of faulty products and following to a report by the purchaser, the seller may at his discretion:

- a) supply ex-factory to the purchaser products of the same kind and quantity as those that proved not in compliance, on receiving returns for checking. Any replacement carried out promptly by the seller cannot be considered as implicit recognition of defects claimed: said recognition must always be explicit and following control by seller on goods challenged; should the seller, on controlling, find the goods in compliance, he will invoice for those sent in replacement; or
- b) issue to the purchaser a credit-note in the amount equal to the value of the defective products. In both cases the purchaser shall return the faulty products to the seller.

8. Limit of the seller's liability

Except in the case of fraud or gross negligence on the seller's part, compensation of any damage to the purchaser will not, in any event, be greater than invoice price of the disputed products.

9. Returned goods

The purchaser needs a written authorization from the seller to return the goods. The authorized returned goods will be free our warehouse in San Maurizio d'Opaglio. The credit note for the returned goods will be defined after the arrival and inspection of our quality / technical department. Damages to the products or to the packaging will be deducted from the credit note.

10. Payments

The payment and every other sum due to the seller, are understood as net at the registered office of the seller. Any delay or irregularity in the payment gives the seller the right to suspend the supply or to cancel the contract in case, even if they are not relevant to

the payments in question as well as the right to compensation for eventual damages. The seller has also the right – starting from the payment deadline – to interests for delay as per art. 5 of Italian Legislative Decree no. 231 of 09/10/2002. The delays of payment likewise give the seller the right to exclusion from guarantee, for the whole period that the delay may persist.

11. Retention of Title

The delivered products remain the seller's property until the moment of the complete payment of the price.

12. Applicable Law and Competent Law-Court

All Contracts ruled by these general conditions are submitted to Italian Law. For any controversy relative to, or connected to the contractual products to which this general conditions apply, court of Novara- branch of Borgomanero has exclusive competence; the latest, however, will have the opportunity to act also in the purchaser's Law-Court.

13. Minimum value for the order

Due to the growing administration cost orders under a value of 100,00 euros will not be taken into consideration. A contribution of a fixed amount of 15,00 euros will be charged on all the orders with a total value between 100,00 and 150,00 euros.

14. Images

Images of our catalogue are a representation of each item but they must not be considered as perfect reproductions. Our company keeps the right to make technical and aesthetical modifications without any previous communication, as well as the right to cancel from the production single items or complete series.



CERTIFICATO

L'Organismo di Certificazione TÜV Rheinland Italia S.r.l.

certifica, in accordo alle procedure TÜV Rheinland Group, che l'azienda

Mario Bongio S.r.l.
Via A. Moro, 2
I - 28017 San Maurizio D'Opaglio (NO)



ha istituito ed attua un sistema di gestione per la qualità
relativo al seguente campo di applicazione:

Progettazione e produzione di rubinetteria sanitaria. EA 18

Mediante un audit, rapporto N° 0460603, è stata conseguita
dimostrazione che il sistema di gestione per la qualità è conforme alla Norma

UNI EN ISO 9001:2008

Fare riferimento al Manuale della Qualità per
i dettagli sulle esclusioni rispetto ai requisiti della norma.

N° di registrazione del certificato: 39 00 0460603.

Il presente certificato è valido dal 28/11/2010 al 28/12/2013.

La data di riferimento per le verifiche di sorveglianza annuali è (giorno/mese): 17/12

Milano, il 26/11/2010. Prima Certificazione: 28/12/2001



Il responsabile della Certificazione
TÜV Rheinland Italia S.r.l., Via E. Mattei, 10 - I - 20103 Pogliano Milanese (MI)



SICQ N° 8884
Member of the Association of Italian Registrars (ASIRI) and IAF
Signatory of the ISO 9001 Mutual Recognition Agreement

www.tuv.com



COLORI E FINITURE

ON - OTTONE NATURALE

finitura naturale che con il tempo, a contatto con l'atmosfera, cambia la tonalità divenendo di colore più scuro sulle superfici di minor contatto.

CR - CROMO

è la finitura più utilizzata, con superfici a specchio e grazie agli spessori elevati, risulta anche la più resistente.

NI - NICHEL LUCIDO

finitura simile al cromo ma dalle tonalità più calde. inizialmente le superfici risultano a specchio, ma con il tempo si ossidano passando ad una tonalità simile all'argento.

OR - ORO

finitura galvanica che si ottiene in bagni elettrolitici di oro 24 k.

OP - ORO SPAZZOLATO

finitura galvanica ottenuta in bagni elettrolitici di oro 24 k con spazzolatura manuale. Ideale per serie moderne.

BR - BRONZO

finitura galvanica ottenuta grazie ad una spazzolatura manuale per esaltare i riflessi metallici chiari e scuri e protetta da una vernice trasparente che ne preserva le caratteristiche. ideale per serie classiche.

AG - ARGENTO ANTICO

finitura galvanica ottenuta grazie ad una spazzolatura manuale e protetta da una vernice trasparente che ne preserva le caratteristiche. Finitura simile al peltro, ideale per serie classiche.

ON - NATURAL BRASS

natural finiture of the raw brass that during the time and in contact with the air, it will change the tonality, becoming more dark over the surfaces of less contact.

CR - CHROME

it is the most required finiture with a mirror surface. our higher thickness of chrome grants higher resistance.

NI - LIGHT NIKEL

finiture very similar to the chrome but more warm. at the beginning you have a mirror-yellow surface. then the time and the air change to a silver tonality.

OR - GOLD

galvanic finiture obtained by 24 kt gold electrolytic processing.

OP - BRUSHED GOLD

manual brushing made on the am gold finiture. this has suggested for the modern collections.

BR - BRONZE

galvanic finiture obtained by a manual brushing that evidences the dark and clear metallic reflections, covered then by a transparent varnish. This finiture it is the best for the classic collections.

AG - OLD SILVER

galvanic finiture obtained through a manual brushing and recovered by a transparent varnish. this finiture is similar to the tonality of the pewter and it has suggested for the classical collections.

PER I COLORI E LE FINITURE NON SPECIFICATE,
QUINDI NON DI SERIE, BONGIO SI RISERVA DI:
1° VERIFICARNE LA FATTIBILITÀ
2° COMUNICARE ADEGUATI TEMPI DI CONSEGNA
3° COMUNICARE EVENTUALI COSTI AGGIUNTIVI

FOR DIFFERENT COLOURS AND FINISHINGS,
BONGIO RESERVE TO:
1° CHECK THE POSSIBILITY TO REALIZE
2° COMMUNICATE ADDITIONAL COST
3° ESTABLISH APPROPRIATE DELIVERY TIMES



CROMO
CHROME



NICHEL LUCIDO
LIGHT NIKEL



ORO
GOLD



OTTONE NATURALE
NATURAL BRASS



ORO SPAZZOLATO
BRUSHED GOLD



BRONZO
BRONZE



ARGENTO ANTICO
OLD SILVER

bongio

Le illustrazioni dei nostri prodotti non costituiscono impegno di fedele esecuzione
Our products illustrations are not pledge of faithful execution



Art Direction
Vanessa Pubblicità Creatività
Print Tipolitografia Testori

EDIZIONE FEBBRAIO 2012

bongio[®]
Made in Italy dal 1936

Mario Bongio srl
Via Aldo Moro, 2
C.P. 108
28017 S. Maurizio
d'Opaglio (NO) - ITALY
Tel. +39 0322 967248
Fax +39 0322 950012

www.bongio.it
info@bongio.it



ioWater[®]

L'acqua non è finita ma non è infinita.

GGIO

CLASSICA DI BONGIO

CLASSICA DI BONGIO

CLASS

CLASSICA DI BONGIO

CLASSICA DI BONGIO

CLASSICA DI BONGIO

GGIO

CLASSICA DI BONGIO

CLASSICA DI BONGIO

CLASS

CLASSICA DI BONGIO

CLASSICA DI BONGIO

CLASSICA DI BONGIO

GGIO

CLASSICA DI BONGIO

CLASSICA DI BONGIO

CLASS

CLASSICA DI BONGIO

CLASSICA DI BONGIO

CLASSICA DI BONGIO

CLASSICA DI BONGIO

CLASSICA DI BONGIO

CLASSICA DI BONGIO

CLASSICA DI BONGIO

CLASSICA DI BONGIO

CLASSICA DI BONGIO

CLASSICA DI BONGIO

CLASSICA DI BONGIO

CLASSICA DI BONGIO

CLASSICA DI BONGIO

CLASSICA DI BONGIO

CLASSICA DI BONGIO