

cisal

WAVE
Collection

design by Cisol Atelier



cisal



cisal

FATTARON

«La bellezza del luogo ci illude, e a momenti ci fa credere che il tempo si sia fermato»

Orta mia. Mario Soldati 1960

“The beauty of this place deceives us, and at times makes us believe that time stands still”

Orta mia. Mario Soldati 1960



CHI SIAMO

CISAL rappresenta un esempio di industria italiana autonoma ed integrata, a ciclo di produzione completo, caratterizzato da soluzioni tecnologiche e gestionali innovative. Cisol è oggi uno dei protagonisti dell'innovazione nel settore, con grande sensibilità per l'efficiente uso delle risorse, in primis acqua ed energia, e costante attenzione allo sviluppo continuo di prodotti innovativi nel design, nei materiali, nel funzionamento e nelle prestazioni. Le Collezioni combinano sapientemente estetica, funzionalità e affidabilità, grazie alla collaborazione con designers internazionali quali Karim Rashid, Giampiero Peia, Fabio Rotella, the Collections masterfully combine aesthetics, functionality and reliability.

ABOUT US

Cisal is the outstanding example of an independent and fully integrated Italian manufacturer, performing the complete production cycle, characterised by innovative technology and management solutions.

Cisal is now one of the leading innovators in the industry and is very conscience about the efficient use of resources, water and energy, and focuses on the continuous development of innovative products with regard to design, materials, function and performance. Thanks to collaboration with international designers such as Karim Rashid, Giampiero Peia, Fabio Rotella, the Collections masterfully combine aesthetics, functionality and reliability.



1952

Fondata nel 1952 da Liborio Soldi e battezzata CISAL, la società ha attraversato tutte le stagioni dell'epopea della rubinetteria di cui il Cusio è protagonista fin dagli albori.

Founded in 1952 by Liborio Soldi and named CISAL, the company has gone through all the epic seasons of brassware industry where Cusio has been the protagonist since the beginning.



1980

Nel 1980 l'Arch. Raffaella Vecchi disegna la serie ARCANA, un prodotto icona classico e storico che apre nuovi orizzonti nei mercati esteri, che si sviluppano passando anche attraverso la creazione di una filiale in Germania nel 1991.

In 1980 the Architect Raffaella Vecchi, designed the ARCANA series, a classical and historical icon that opens up new horizons in foreign markets, which also led to the establishment of a daughter company in Germany in 1991.



1981

Dal lavoro di sviluppo interno coordinato da Daniele Sirini, nasce la prima cartuccia a dischi ceramici monocomando. Il nuovo BLITZ apre la gloriosa storia delle serie di miscelazione Cisol.

The first single handle ceramic disc cartridge was developed internally by Daniele Sirini and his team. The glorious history of Cisol mixer series begins with the new BLITZ series.



1999

Nel 1999, viene realizzato un nuovo stabilimento disegnato dall'Arch. Giampiero Peia e attrezzato con modernissimi impianti di cogenerazione, galvanica e magazzino elettronico. Qui si concentrano le tecnologie più avanzate del settore e si supporta una crescita continua nella progettazione del prodotto, nell'ingegnerizzazione del manufatto e del prodotto finito.

In 1999, a new factory building designed by the architect Giampiero Peia was built and equipped with modern cogeneration and plating plants along with an electronic warehouse. Here, using the most advanced technologies in the industry, product design and the engineering of the part and the finished product are in continuous development.



2009

Nel 2009 la famiglia Huber, proprietaria di Huber, leader nella fabbricazione di miscelatori termostatici, decide di fare una scelta strategica per il futuro, acquisendo Cisol per garantirle un asse di sviluppo tecnologico e industriale assolutamente vincente: combinare know-how, esperienza e capacità produttive per offrire al progettista e alla clientela una variegata e completa gamma di prodotti integrati a miscelazione termostatica, monocomando e tradizionale.

In 2009 the Huber family, owner of Huber, a leading manufacturer of thermostatic mixers, decided to make a strategic choice for the future, by acquiring Cisol and providing the company with an absolutely successful technological and industrial development format: to combine know-how, experience and production capacities in order to offer designers and customers a wide and complete range of single lever, traditional, and thermostatic brassware products.



2016

Nel 2016 l'Architetto Fabio Rotella entra a far parte del team dell'azienda e in qualità di art director ha ideato "CISALAtelier", centro creativo che, attraverso la ricerca e la sperimentazione, lavora su progetti di prodotti sempre più protagonisti, grazie ad un autentico appeal.

Architect Fabio Rotella joining the team in 2016 as the brand art director, he developed the "CISALAtelier" concept, a creative network which, through research and experimentation, will be protagonist on projects of key products thanks to their authentic appeal.



ECCELLENZA MADE IN ITALY

Cisal rappresenta un capitolo importante della storia della rubinetteria italiana. Una lunga tradizione di ingegno, mestiere e professionalità, declinata ed esaltata nel rispetto e nella considerazione per l'uomo ed il territorio: il Lago d'Orta, luogo in cui si concentra da generazioni il distretto della rubinetteria, retaggio di artigianalità e cultura del saper fare italiano.

MADE IN ITALY EXCELLENCE

Cisal represents an important chapter in the history of Italian brassware. A long tradition of ingenuity, skill and professionalism, identified and enhanced in respect and consideration for humans and the territory: Lake Orta, the area where taps have been made for generations, has a heritage of craftsmanship and a culture of Italian know-how.



cisal *Atelier* **CONCEPT**

L'acqua è l'elemento essenziale per l'essere umano e il suo controllo è importante sin dall'antichità. Il rubinetto, dispensatore del liquido vitale del quale facciamo un utilizzo quotidiano, è un prodotto funzionale e necessario ma può anche rappresentare un accessorio sofisticato, prezioso e sempre più protagonista nell'ambiente bagno. Cisol storicamente ha da sempre caratterizzato la sua vasta gamma di collezioni con un atteggiamento di ricerca formale riferito al design. Più recentemente, con l'integrazione delle competenze della famiglia Huber, Cisol si è ulteriormente elevata ad ancora più alti livelli di qualità e prestigio, affermandosi come un importante interprete del settore bagno e cucina a livello internazionale.

Nel 2016 l'Architetto Fabio Rotella entra a far parte del team dell'azienda e in qualità di art director ha ideato "CISALAtelier", centro creativo che, attraverso la ricerca e la sperimentazione, lavora su progetti di prodotti sempre più protagonisti, grazie ad un autentico appeal.

"In questi anni di grandi cambiamenti, in un contesto internazionale sempre più sofisticato e in continua evoluzione, Cisol, nella sua nuova visione strategica, intende sviluppare ed elevare la propria immagine rendendola unica e riconoscibile, e aumentare la percezione dei suoi prodotti e delle sue innovazioni sullo scenario globale. Nuovi materiali, nuove finiture, nuovi dettagli e nuove tecnologie per controllare e preservare l'acqua. Cisol si presenta come un'azienda Italiana di tradizione e all'avanguardia, proiettata verso il futuro e sempre più attenta alle attese di designers e utilizzatori e alla salvaguardia dell'elemento essenziale per il Pianeta: l'acqua."

Fabio Rotella

Water is the essential element for the human being - and controlling it has been important since ancient times.

The tap, dispenser of this vital liquid of which we use daily, is a functional and necessary product, but it can also be a sophisticated, precious accessory as well that plays an increasingly important role in the bathroom environment. Since its origin, Cisol's wide range of collections have always been characterized by formal research related to design. Recently, with the integration of the expertise of the Huber family, Cisol has elevated its already high levels of quality and prestige even further, establishing itself internationally as a major interpreter of the bathroom and kitchen industry.

Architect Fabio Rotella joining the team in 2016 as the brand art director, he developed the "CISALAtelier" concept, a creative network which, through research and experimentation, will be used on projects of key products thanks to their authentic appeal.

"During these years of great change, in an international context that is becoming more sophisticated and is constantly evolving, Cisol, with its new strategic vision, aims to develop and enhance its image, making it unique and recognizable, and to globally increase the perception of its products and innovations. New materials, new finishes, new details and new technologies to control and preserve water. Cisol is a cutting-edge, future-oriented Italian company that is rich in tradition and is increasingly aware of the expectations of designers and users, and the preservation of the essential element of our planet: water."

Fabio Rotella



WATER CREATIVITY

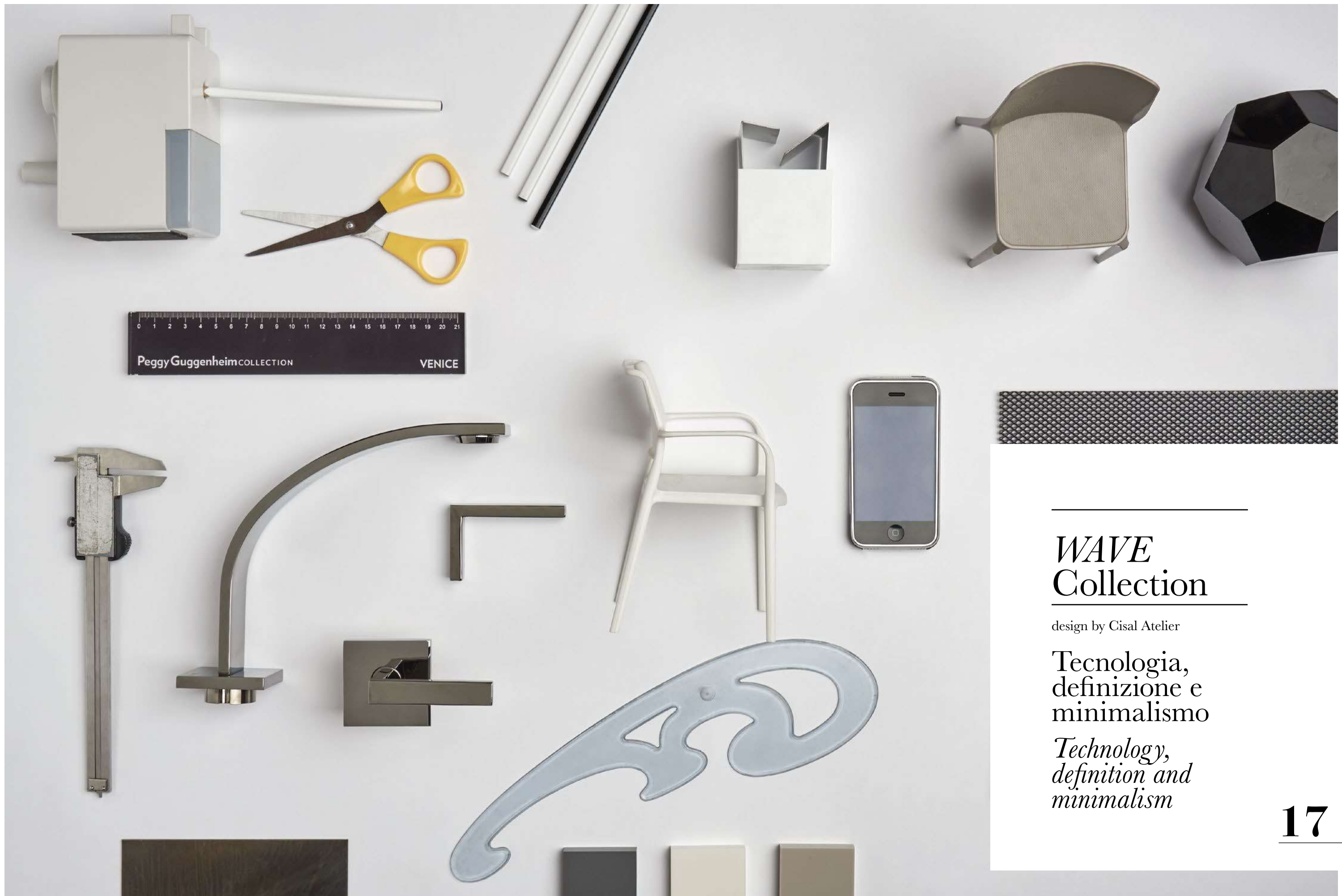

WAVE Collection

design by Cital Atelier

Tecnologia,
definizione e
minimalismo

*Technology,
definition and
minimalism*

WAVE



18

WA 102
Batteria Lavabo
Basin Set



19

WAVE



20

WA 751
Batteria Lavabo
Basin Set



WA 106
Batteria Lavabo
Basin Set

21

WAVE



22

WA 351
Monocomando Lavabo
Basin Mixer



23

WAVE



24

WA 251
Monocomando Lavabo
Basin Mixer



25

WAVE



WA 51
Monocomando Lavabo
Basin Mixer

26



WA 55
Monocomando Bidet
Bidet Mixer



WA 652
Monocomando Lavabo
Basin Mixer

27

WAVE



28

WE C8601
CombiDoccia Termostatico
Thermo CombiShower

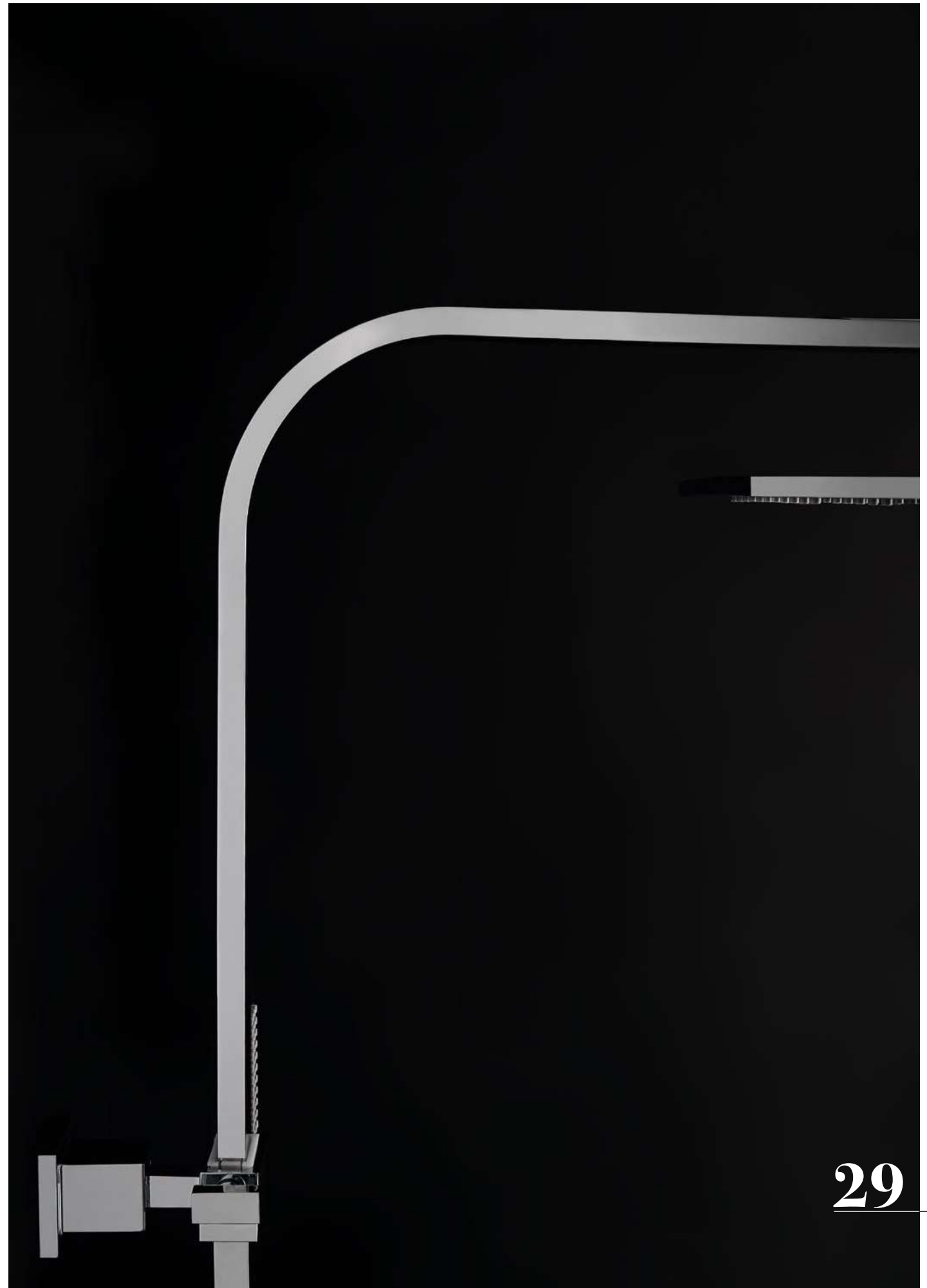

29

WAVE



WA 500
CombiDoccia Termostatico
Thermo CombiShower

30



ZS 2707
Soffione Doccia a Controsoffitto Cromoterapia
Ceiling Mounted Cromotherapy Shower Head



ZS 2559
Soffione Doccia a Controsoffitto 2 Funzioni
2-Function Ceiling Mounted Shower Head

31

WAVE



32

WA 110
Completo Monocomando Vasca
Bath Mixer Set



WA 21
Completo Monocomando 2 Funzioni
2-Function Mixer Set



33

WAVE



34

WA 26
Batteria Vasca
Bath Set



35

WAVE



36

WA 21
Completo Monocomando 2 Funzioni
2-Function Mixer Set

WA 24
Bocca di Erogazione
Filler Spout



DS 1374
Braccio e Soffione Doccia
Shower Arm & Head



WA 1910
Termostatico 2 Uscite
2-Outlet Thermo

37

WAVE



38



WA 1319
Braccio e Soffione Doccia
Shower Arm & Head

WE 1910
Termostatico 2 Uscite
2-Outlet Thermo

DS 1886
Completo Doccia con Presa d'Acqua
Shower Set on Wall Elbow



39

WAVE



40

WA 1319
Braccio e Soffione Doccia
Shower Arm & Head



41

WAVE

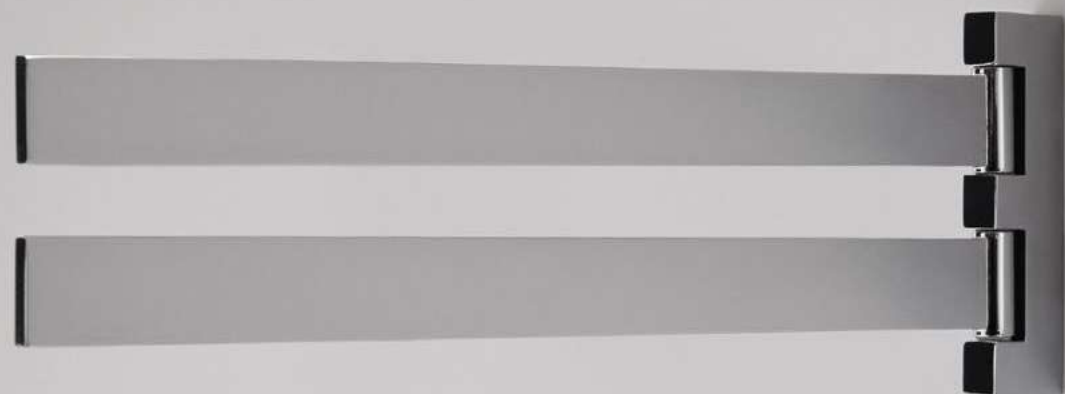

QU 9021
Porta Salviette
Towel Rail



QU 9091
Porta Salviette
Free-Standing Towel Rail



QU 9062
Dispenser Sapone
Soap Dispenser



QU 90104
QU 90105
QU 90106
Porta Salviette
Towel Rail



Prodotti e Accessori
Products and Accessories
Produits et Accessoires

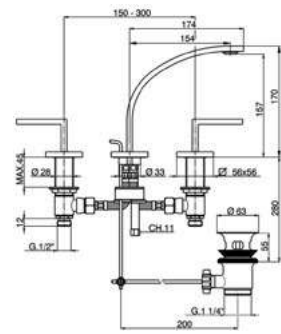

WA 001021
Batteria Lavabo
Basin Set
Lavabo 3 Trous

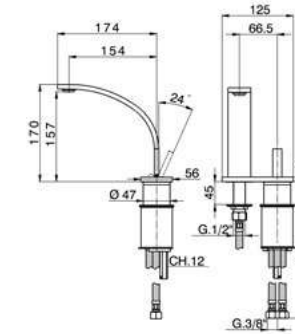

WA 006520
Monocomando Lavabo
Basin Mixer
Mitigeur Lavabo

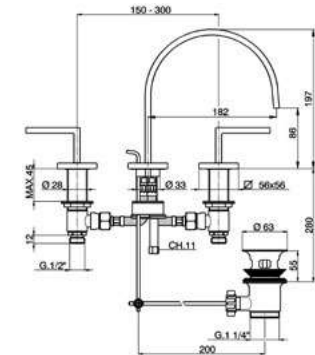

WA 001060
Batteria Lavabo
Basin Set
Lavabo 3 Trous

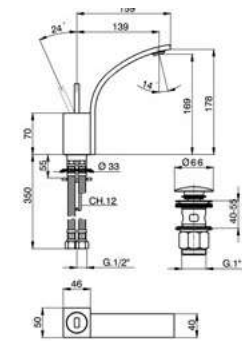

WA 000512
Monocomando Lavabo
Basin Mixer
Mitigeur Lavabo

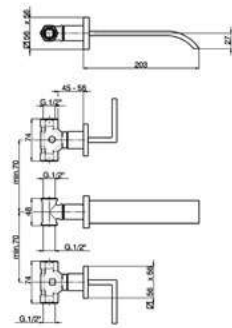

WA 007510
Batteria Lavabo
Basin Set
Lavabo 3 Trous

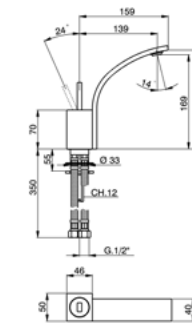

WA 000542
Monocomando Lavabo
Basin Mixer
Mitigeur Lavabo

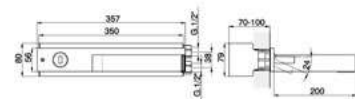

WA 002511
Monocomando Lavabo
Basin Mixer
Mitigeur Lavabo

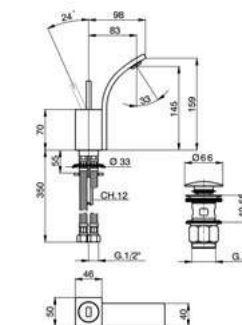

WA 000552
Monocomando Bidet
Bidet Mixer
Mitigeur Bidet

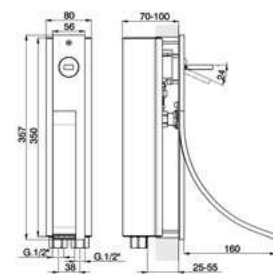

WA 003511
Monocomando Lavabo
Basin Mixer
Mitigeur Lavabo

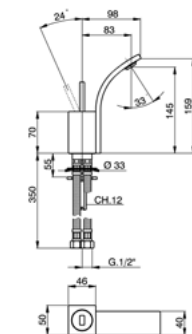

WA 000562
Monocomando Bidet
Bidet Mixer
Mitigeur Bidet

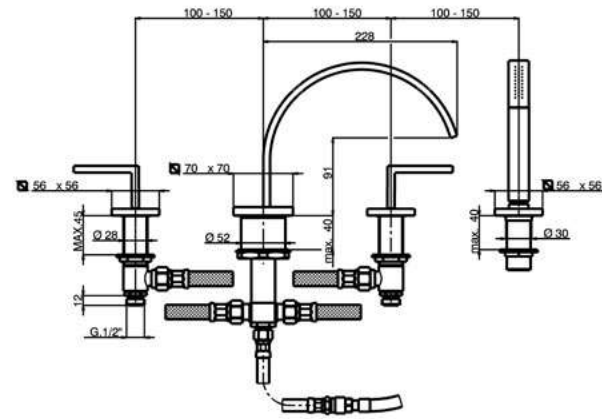

WA 000261
Batteria Bordo Vasca
Deck Mounted Bath Set
Ensemble Bain/D. sur Gorge

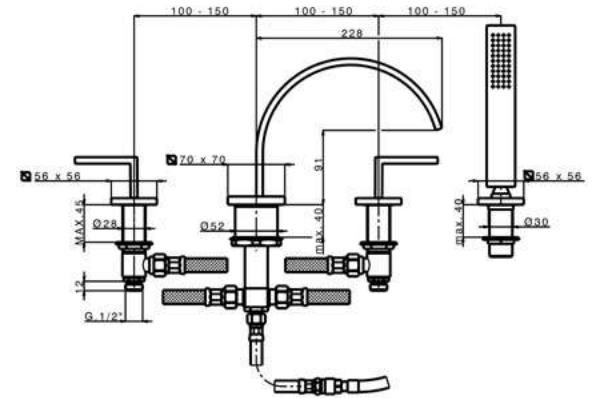

WA 000262
Batteria Bordo Vasca
Deck Mounted Bath Set
Ensemble Bain/D. sur Gorge

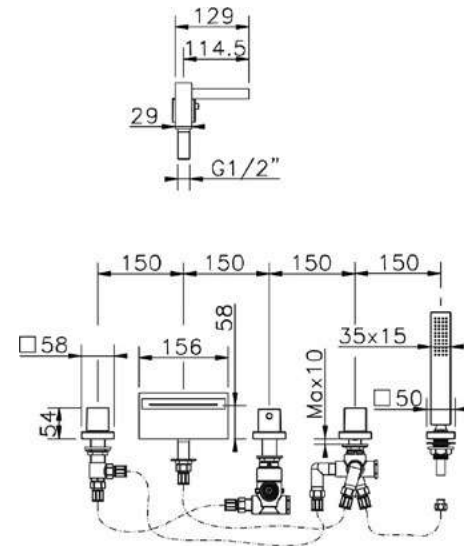

WE T77010
Batteria Termostatico Bordo Vasca
Thermo Deck Mounted Bath Set
Ensemble Bain/D. Thermo sur Gorge

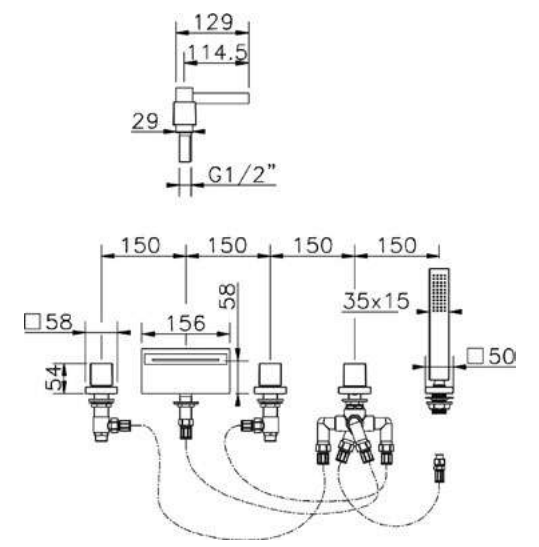
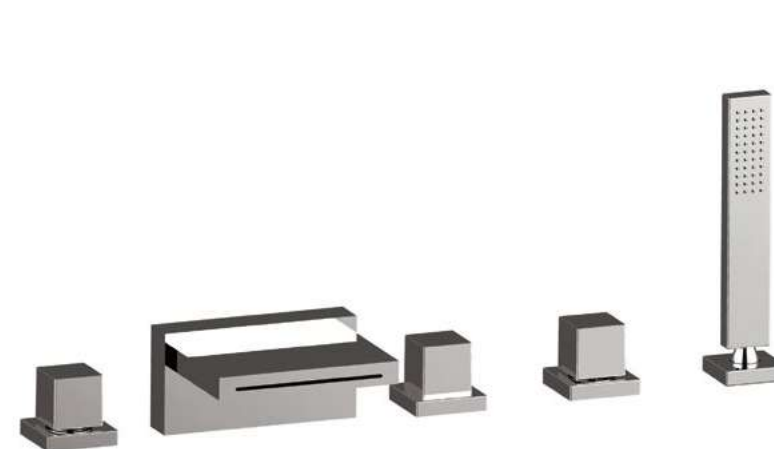

WE 000260
Batteria Bordo Vasca
Deck Mounted Bath Set
Ensemble Bain/D. sur Gorge

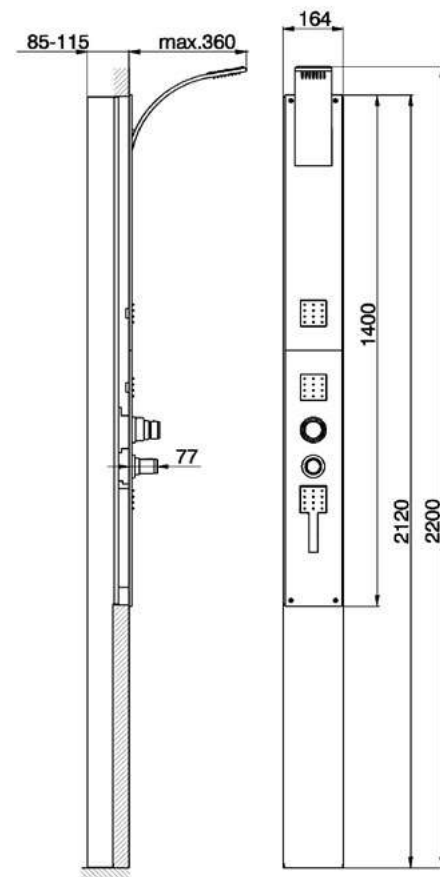

WA 00500
CombiDoccia Termostatico
Thermo CombiShower
CombiDouche Thermo

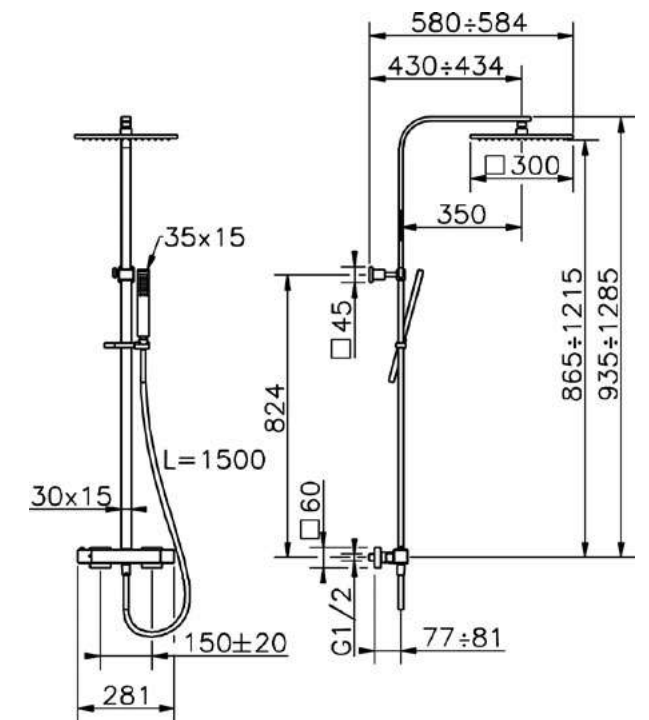

WE C8601H
CombiDoccia Termostatico
Thermo CombiShower
CombiDouche Thermo

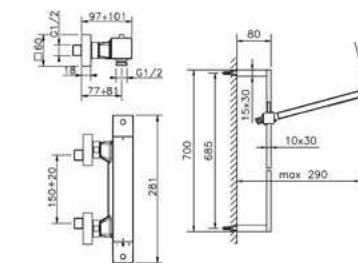

WE S01010
Completo Termostatico Doccia
Thermo Shower Set
Ensemble Thermo Douche

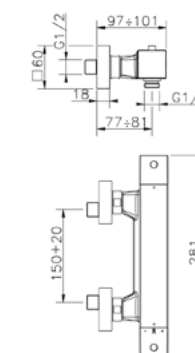

WE T01010
Termostatico Doccia
Shower Thermo
Thermo Douche

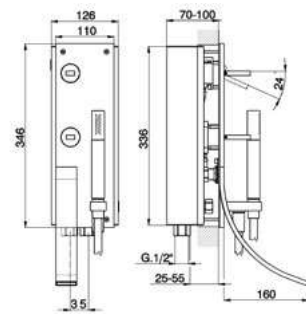

WA 001100
Completo Monocomando Vasca
Bath Mixer Set
Ensemble Mitigeur Bain/D.

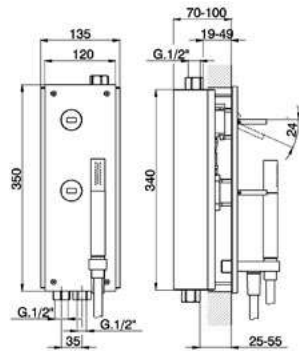

WA 000210
Completo Monocomando 2 Funzioni
2-Function Mixer Set
Ensemble Mitigeur 2 Fonctions

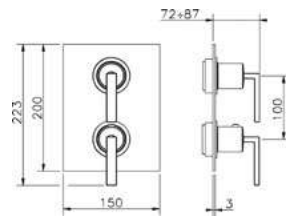

WA 009300
Parte Esterna Termostatico Doccia
Thermo Shower Exposed Part
Partie Décor Thermo Douche

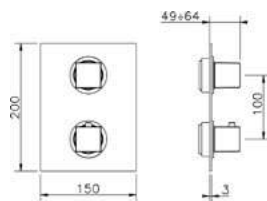

WE 009300
Parte Esterna Termostatico Doccia
Thermo Shower Exposed Part
Partie Décor Thermo Douche

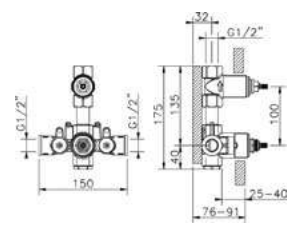

ZA 009301
Parte Incasso Termostatico Doccia
Thermo Shower Concealed Part
Partie Encastrée Thermo Douche

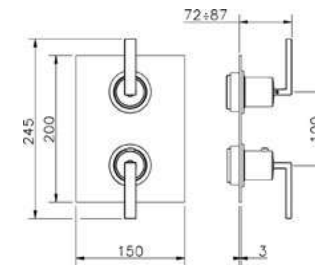

WA 019100
Parte Esterna Termostatico 2 Uscite
2-Outlet Thermo Exposed Part
Partie Décor Thermo 2 Sorties

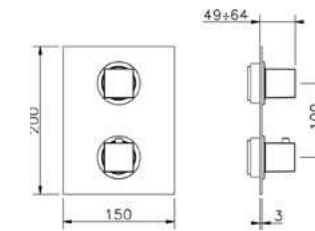

WE 019100
Parte Esterna Termostatico 2 Uscite
2-Outlet Thermo Exposed Part
Partie Décor Thermo 2 Sorties

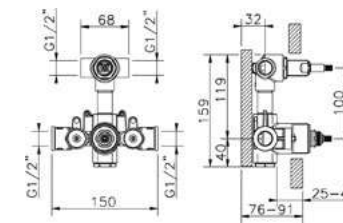

ZA 019101
Parte Incasso Termostatico 2 Uscite
2-Outlet Thermo Concealed Part
Partie Encastrée Thermo 2 Sorties

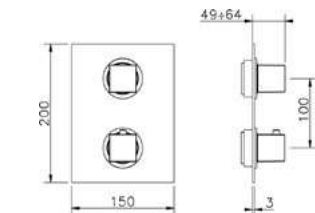

WE 019200
Parte Esterna Termostatico 3 Uscite
3-Outlet Thermo Exposed Part
Partie Décor Thermo 3 Sorties

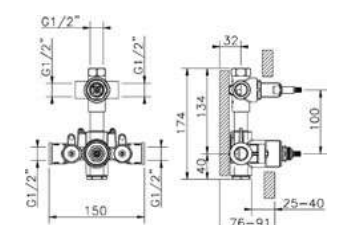

ZA 019201
Parte Incasso Termostatico 3 Uscite
3-Outlet Thermo Concealed Part
Partie Encastrée Thermo 3 Sorties

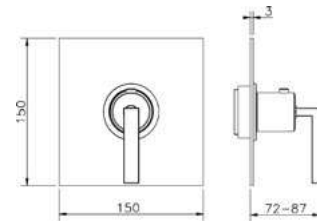

WA 007200
 Parte Esterna Termostatico 3/4"
 3/4" Thermo Exposed Part
 Partie Décor Thermo 3/4"

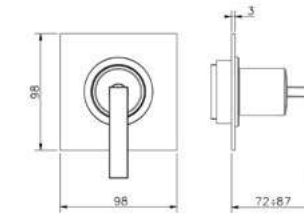

WA 003310
 Parte Esterna Rubinetto
 Stopvalve Exposed Part
 Partie Décor Robinet

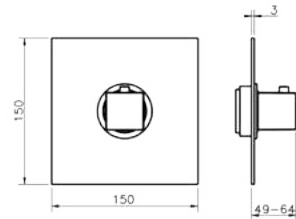

WE 007200
 Parte Esterna Termostatico 3/4"
 3/4" Thermo Exposed Part
 Partie Décor Thermo 3/4"

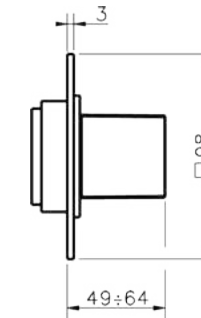

WE 003310
 Parte Esterna Rubinetto
 Stopvalve Exposed Part
 Partie Décor Robinet

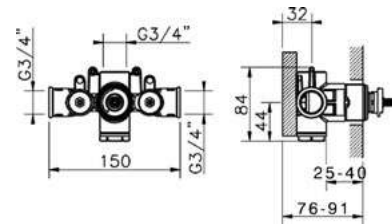

ZA 007221
 Parte Incasso Termostatico 3/4"
 3/4" Thermo Concealed Part
 Partie Encastrée Thermo 3/4"

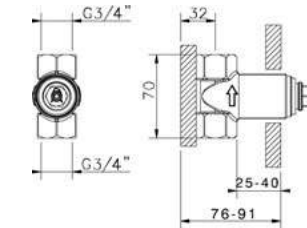

ZA 003330
 Parte Incasso Rubinetto 3/4"
 3/4" Stopvalve Concealed Part
 Partie Encastrée Robinet 3/4"

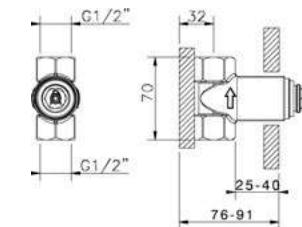

ZA 003340
 Parte Incasso Rubinetto 1/2"
 1/2" Stopvalve Concealed Part
 Partie Encastrée Robinet 1/2"

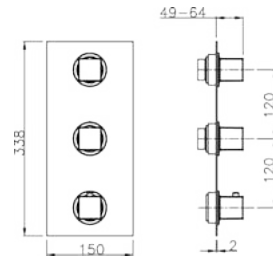

WE 01V200
 Parte Esterna Termostatico 2 Funzioni
 2-Function Thermo Exposed Part
 Partie Décor Thermo 2 Fonctions

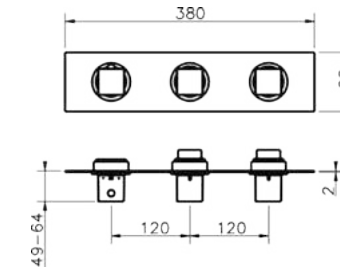

WE 01R200
 Parte Esterna Termostatico 2 Funzioni
 2-Function Thermo Exposed Part
 Partie Décor Thermo 2 Fonctions

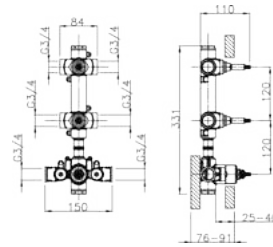

ZA 01V200
 Parte Incasso Termostatico 2 Funzioni
 2-Function Thermo Concealed Part
 Partie Encastrée Thermo 2 Fonctions

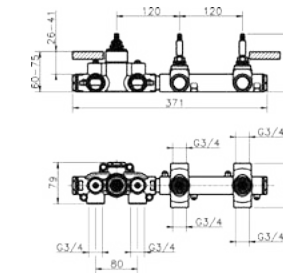

ZA 01R200
 Parte Incasso Termostatico 2 Funzioni
 2-Function Thermo Concealed Part
 Partie Encastrée Thermo 2 Fonctions

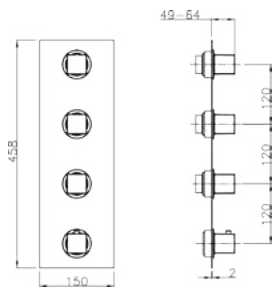

WE 01V300
 Parte Esterna Termostatico 3 Funzioni
 3-Function Thermo Exposed Part
 Partie Décor Thermo 3 Fonctions

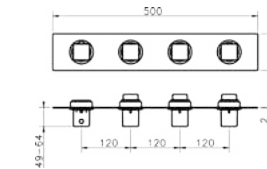

WE 01R300
 Parte Esterna Termostatico 3 Funzioni
 3-Function Thermo Exposed Part
 Partie Décor Thermo 3 Fonctions

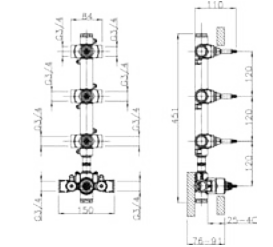

ZA 01V300
 Parte Incasso Termostatico 3 Funzioni
 3-Function Thermo Concealed Part
 Partie Encastrée Thermo 3 Fonctions

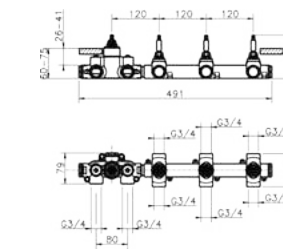

ZA 01R300
 Parte Incasso Termostatico 3 Funzioni
 3-Function Thermo Concealed Part
 Partie Encastrée Thermo 3 Fonctions

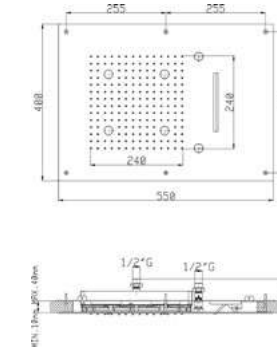
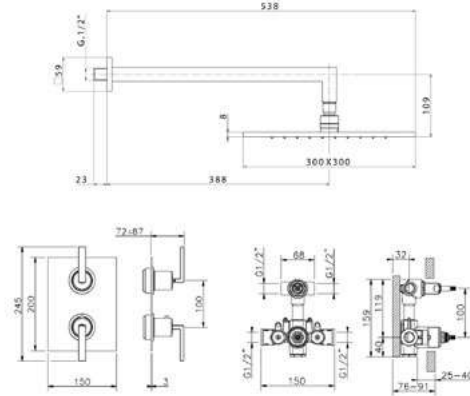

ZS 027070
Soffione Doccia a Controsoffitto Cromoterapia
4 Led RGB
3 Funzioni: Pioggia/Cascata/Nebulizzazione
Ceiling Mounted 4-Led RGB Chromotherapy
Shower Head
3 Functions: Rain/Waterfall/Nebulization
Ciel de Pluie Encastré Chromothérapie
4 Led RGB
3 Fonctions: Pluie/Cascade/Nébulisation



WA 0KT010
Completo Termostatico Doccia 2 Funzioni
2-Function Thermo Shower Set
Ensemble Thermo Douche 2 Fonctions

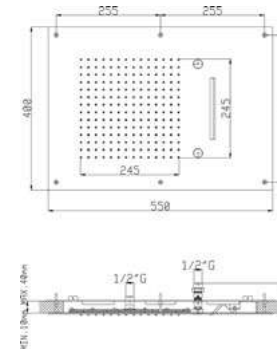
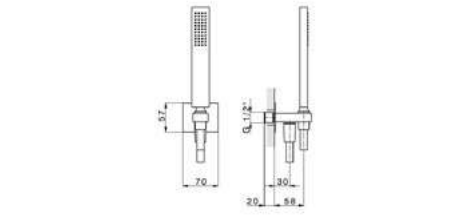

ZS 025580
Soffione Doccia a Controsoffitto
3 Funzioni: Pioggia/Cascata/Nebulizzazione
Ceiling Mounted Shower Head
3 Functions: Rain/Waterfall/Nebulization
Ciel de Pluie Encastré
3 Fonctions: Pluie/Cascade/Nébulisation

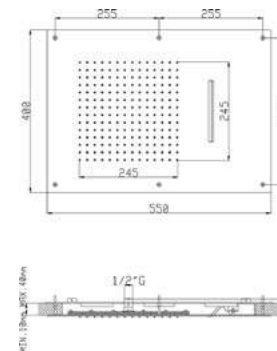

ZS 025590
Soffione Doccia a Controsoffitto
2 Funzioni: Pioggia/Cascata
Ceiling Mounted Shower Head
2 Functions: Rain/Waterfall
Ciel de Pluie Encastré
2 Fonctions: Pluie/Cascade

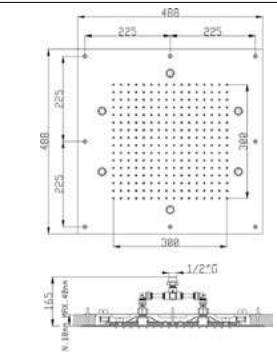
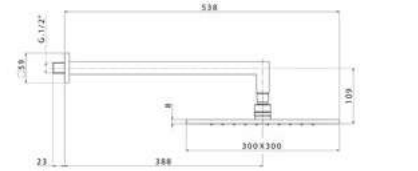

ZS 027110
Soffione Doccia a Controsoffitto Cromoterapia
6 Led RGB
Ceiling Mounted 6-Led RGB Chromotherapy
Shower Head
Ciel de Pluie Encastré Chromothérapie
6 Led RGB



WE 0KT010
Completo Termostatico Doccia 2 Funzioni
2-Function Thermo Shower Set
Ensemble Thermo Douche 2 Fonctions

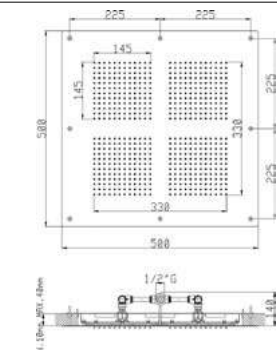
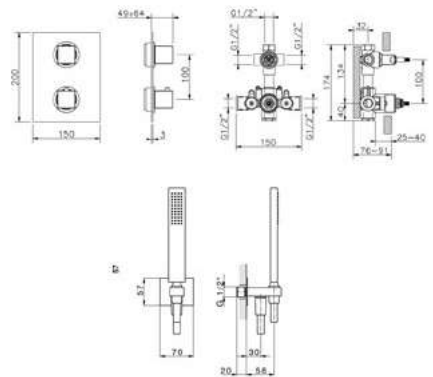

ZS 025610
Soffione Doccia a Controsoffitto
Ceiling Mounted Shower Head
Ciel de Pluie Encastré

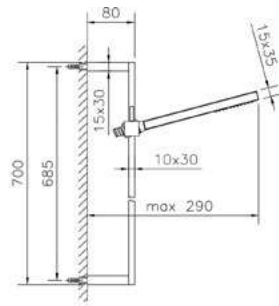

DS 010770
Completo Doccia Saliscendi
Slide Rail Shower Set
Ensemble Barre de Douche

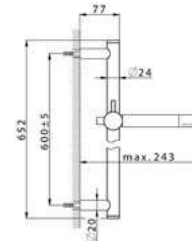

DS 010721
Completo Doccia Saliscendi
Slide Rail Shower Set
Ensemble Barre de Douche

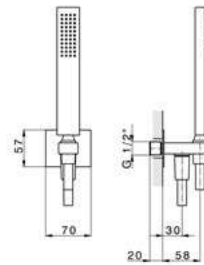

DS 018860
Completo Doccia con Presa d'Acqua
Shower Set on Wall Elbow
Ensemble de Douche sur Coude Mural

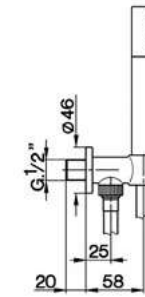

DS 018813
Completo Doccia con Presa d'Acqua
Shower Set on Wall Elbow
Ensemble de Douche sur Coude Mural

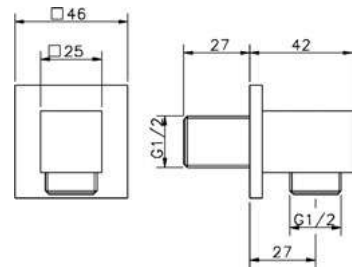

DS 017340
Presa d'Acqua
Wall Elbow
Coude Mural

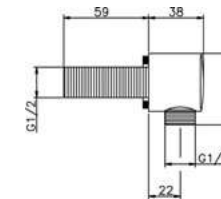

DS 017320
Presa d'Acqua
Wall Elbow
Coude Mural

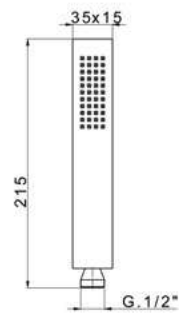

DS 014450
Doccetta Ottone
Brass Hand Shower
Douchette à Main Laiton

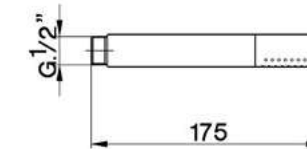

DS 014090
Doccetta
Hand Shower
Douchette à Main

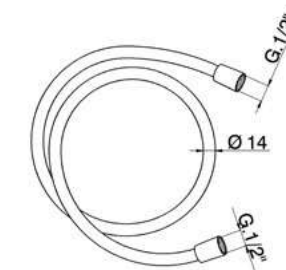

ZA 009040
Flessibile Doccia SUPREME
SUPREME Shower Hose
Flexible de Douche SUPREME

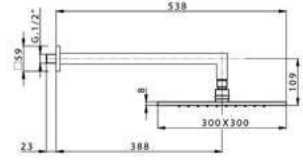

DS 013720
Braccio e Soffione Doccia
Shower Arm & Head
Bras et Tête de Douche

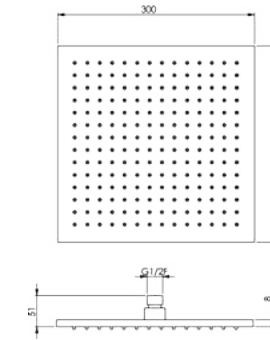

DS 016340
Soffione Doccia
Shower Head
Douche de Tête

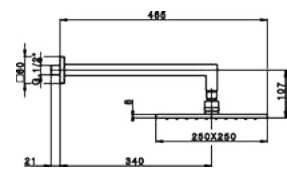

DS 013660
Braccio e Soffione Doccia
Shower Arm & Head
Bras et Tête de Douche

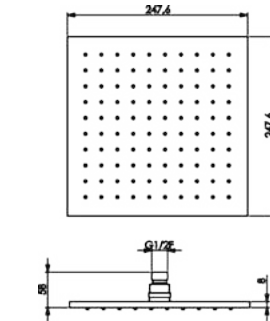

DS 016360
Soffione Doccia
Shower Head
Douche de Tête

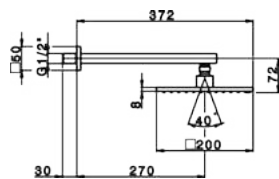

DS 013650
Braccio e Soffione Doccia
Shower Arm & Head
Bras et Tête de Douche

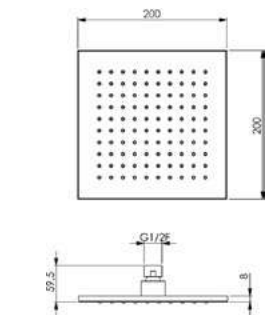

DS 016320
Soffione Doccia
Shower Head
Douche de Tête

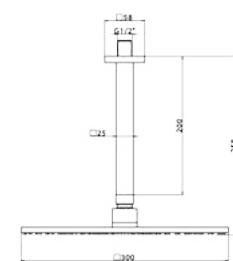

DS 013740
Braccio e Soffione Doccia
Shower Arm & Head
Bras et Tête de Douche

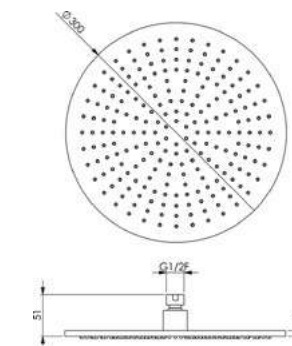
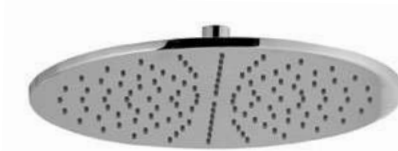

DS 016330
Soffione Doccia
Shower Head
Douche de Tête

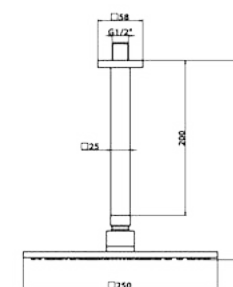

DS 013730
Braccio e Soffione Doccia
Shower Arm & Head
Bras et Tête de Douche

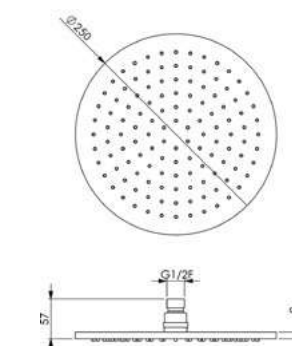
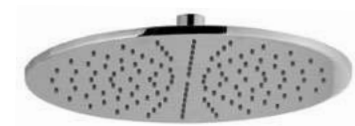

DS 016350
Soffione Doccia
Shower Head
Douche de Tête

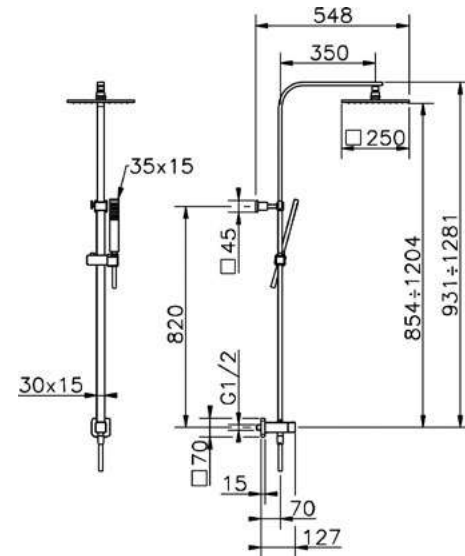

DS V86030
Completo Doccia con Presa d'Acqua
Shower Set on Wall Elbow
Ensemble de Douche sur Coude Mural

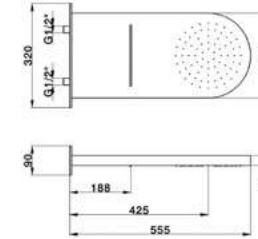

DS 013570
Soffione Doccia 2 Funzioni: Pioggia/Cascata
2-Function Shower Head: Rain/Waterfall
Douche de Tête 2 Fonctions: Pluie/Cascade

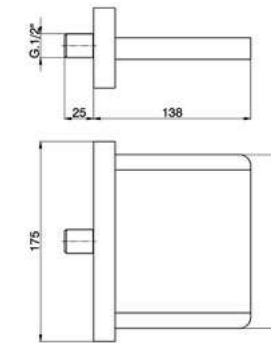

ZA 002190
Bocca a Cascata
Waterfall Spout
Bec Cascade

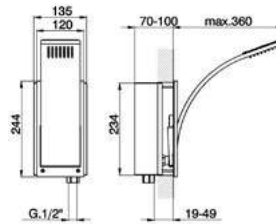

WA 013190
Braccio e Soffione Doccia
Shower Arm & Head
Bras et Tête de Douche

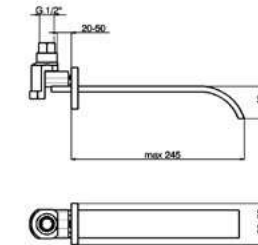

WA 000240
Bocca di Erogazione
Filler Spout
Bec Verseur

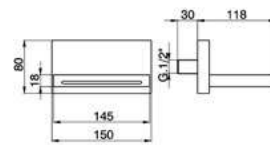

ZA 002200
Bocca a Cascata
Waterfall Spout
Bec Cascade

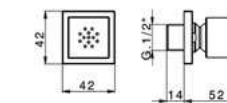

DS 015080
Soffione Laterale
Body Jet
Buse Murale

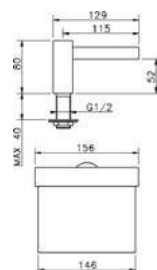

ZA 002620
Bocca Vasca a Cascata
Waterfall Bath Spout
Bec Bain Cascade

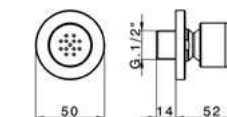

DS 015090
Soffione Laterale
Body Jet
Buse Murale

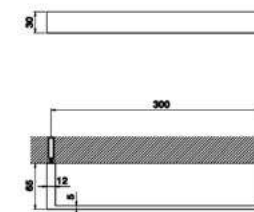

QU 090104
Porta Salviette
Towel Rail
Porte-Serviette

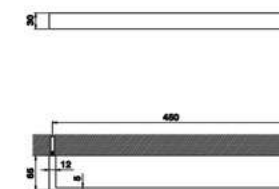

QU 090105
Porta Salviette
Towel Rail
Porte-Serviette

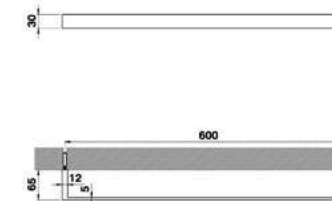

QU 090106
Porta Salviette
Towel Rail
Porte-Serviette

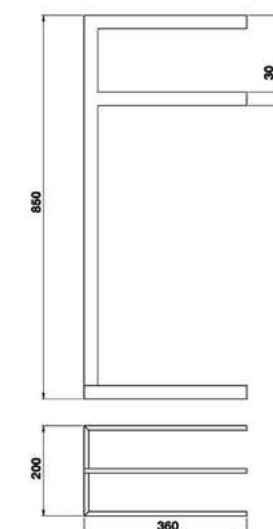

QU 090910
Porta Salviette
Free-Standing Towel Rail
Porte-Serviette

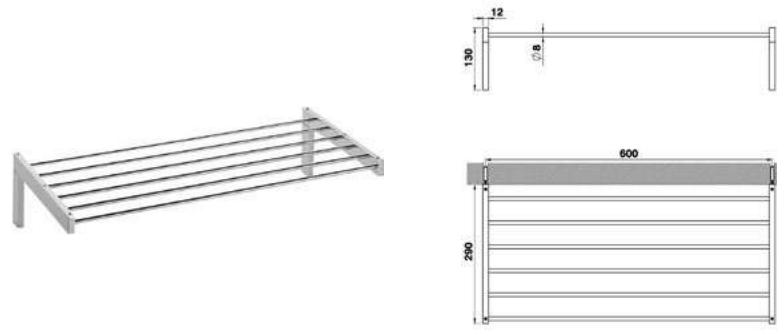

QU 090300
Porta Salviette
Towel Rail
Porte-Serviette

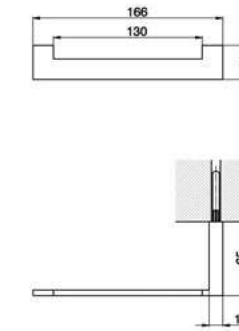

QU 090402
Porta Rotolo
Roll Holder
Porte-Papier

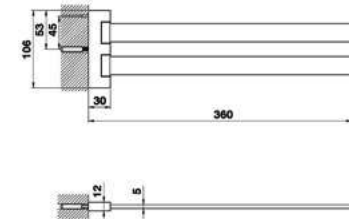

QU 090210
Porta Salviette
Towel Rail
Porte-Serviette

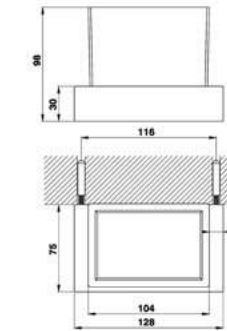

QU 090501
Porta Bicchiera
Toothbrush Holder
Porte-Verre

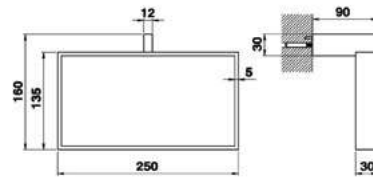

QU 090220
Porta Salviette
Towel Rail
Porte-Serviette

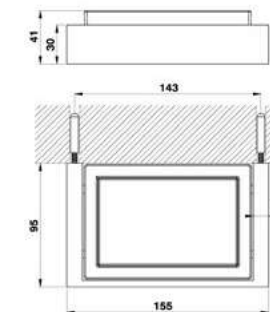

QU 090601
Porta Sapone
Soap Holder
Porte-Savon

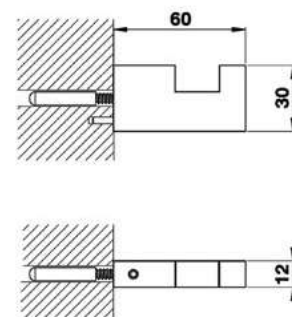
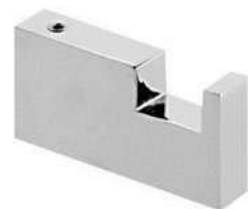

QU 090710
Appendino
Hook
Porte-Peignoir

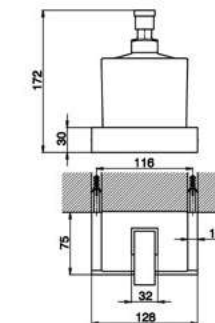

QU 090621
Dispenser Sapone
Soap Dispenser
Diffuseur de Savon

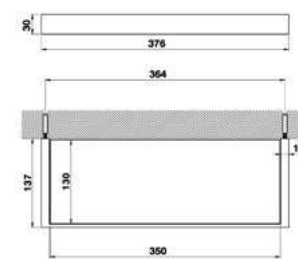

QU 090441
Mensola
Shelf
Console

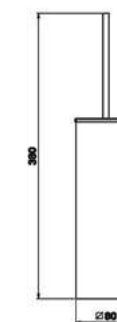

QU 090650
Porta Scopino
Brush Holder
Porte-Brosse

METALLI CLASSICI | CLASSIC METALS



Chrome
21



Brushed Nickel

METALLI SPECIALI PVD | PVD SPECIAL METALS



Black Titanium
2Q

Art Direction Studio Rotella

CREDITS

Text and Editing
CISAL Atelier

Art Direction
Fabio Rotella

Graphic Design and Layout
Studio Rotella Milano

Photography
Dario De Sirianna
Marco Siracusano

Printing
Tipolitografia Testori

Thanks to
“Museo del Rubinetto e della sua Tecnologia”

Printed in Italy

cisal

cisal

cisal



CISAL
28010 Alzo di Pella (NO) - Italia - Via Pietro Durio 160 - Tel. +39 0322 918111 - Fax +39 0322 969518
cisal@cisal.it - www.cisal.it